



Agilent X-Series Signal Analyzer

**This manual provides documentation for the
for the following analyzers:**

**PXA Signal Analyzer N9030A
MXA Signal Analyzer N9020A
EXA Signal Analyzer N9010A
CXA Signal Analyzer N9000A**

**N9075A & W9075A
802.16 OFDMA (WiMAX/
WiBro) Measurement
Application Measurement
Guide**



Agilent Technologies

Notices

© Agilent Technologies, Inc. 2006 - 2010

No part of this manual may be reproduced in any form or by any means (including electronic storage and retrieval or translation into a foreign language) without prior agreement and written consent from Agilent Technologies, Inc. as governed by United States and international copyright laws.

Trademark Acknowledgements

Microsoft ® is a U.S. registered trademark of Microsoft Corporation.

Windows ® and MS Windows ® are U.S. registered trademarks of Microsoft Corporation.

Adobe Reader ® is a U.S. registered trademark of Adobe System Incorporated.

Java™ is a U.S. trademark of Sun Microsystems, Inc.

MATLAB ® is a U.S. registered trademark of Math Works, Inc.

Norton Ghost™ is a U.S. trademark of Symantec Corporation. “WiMAX,” “WiMAX Forum,” “WiMAX Certified,”

“WiMAX Forum Certified,” the WiMAX Forum logo and the WiMAX Forum Certified Logo are trademarks or registered trademarks of the WiMAX Forum. All other product and service names mentioned herein are the marks of their respective owners.

Manual Part Number

N9075-90013

Supersedes: February 2009

Print Date

July 2010

Printed in USA

Agilent Technologies, Inc.
1400 Fountaingrove Parkway
Santa Rosa, CA 95403

Warranty

The material contained in this document is provided “as is,” and is subject to being changed, without notice, in future editions. Further, to the maximum extent permitted by applicable law, Agilent disclaims all warranties, either express or implied, with regard to this manual and any information contained herein, including but not limited to the implied warranties of merchantability and fitness for a particular purpose. Agilent shall not be liable for errors or for incidental or consequential damages in connection with the furnishing, use, or performance of this document or of any information contained herein. Should Agilent and the user have a separate written agreement with warranty terms covering the material in this document that conflict with these terms, the warranty terms in the separate agreement shall control.

Technology Licenses

The hardware and/or software described in this document are furnished under a license and may be used or copied only in accordance with the terms of such license.

Restricted Rights Legend

If software is for use in the performance of a U.S. Government prime contract or subcontract, Software is delivered and

licensed as “Commercial computer software” as defined in DFAR 252.227-7014 (June 1995), or as a “commercial item” as defined in FAR 2.101(a) or as “Restricted computer software” as defined in FAR 52.227-19 (June 1987) or any equivalent agency regulation or contract clause. Use, duplication or disclosure of Software is subject to Agilent Technologies’ standard commercial license terms, and non-DOD Departments and Agencies of the U.S. Government will receive no greater than Restricted Rights as defined in FAR 52.227-19(c)(1-2) (June 1987). U.S. Government users will receive no greater than Limited Rights as defined in FAR 52.227-14 (June 1987) or DFAR 252.227-7015 (b)(2) (November 1995), as applicable in any technical data.

Safety Notices

CAUTION

A CAUTION notice denotes a hazard. It calls attention to an operating procedure, practice, or the like that, if not correctly performed or adhered to, could result in damage to the product or loss of important data. Do not proceed beyond a CAUTION notice until the indicated conditions are fully understood and met.

WARNING

A WARNING notice denotes a hazard. It calls attention to an operating procedure, practice, or the like that, if not correctly performed or adhered to, could result in personal injury or death. Do not proceed beyond a WARNING notice until the indicated conditions are fully understood and met.

Warranty

This Agilent technologies instrument product is warranted against defects in material and workmanship for a period of one year from the date of shipment. During the warranty period, Agilent Technologies will, at its option, either repair or replace products that prove to be defective.

For warranty service or repair, this product must be returned to a service facility designated by Agilent Technologies. Buyer shall prepay shipping charges to Agilent Technologies and Agilent Technologies shall pay shipping charges to return the product to Buyer. However, Buyer shall pay all shipping charges, duties, and taxes for products returned to Agilent Technologies from another country.

Where to Find the Latest Information

Documentation is updated periodically. For the latest information about this analyzer, including firmware upgrades, application information, and product information, see the following URLs:

<http://www.agilent.com/find/pxa>

<http://www.agilent.com/find/mxa>

<http://www.agilent.com/find/exa>

<http://www.agilent.com/find/cxa>

To receive the latest updates by email, subscribe to Agilent Email Updates:

<http://www.agilent.com/find/emailupdates>

Information on preventing analyzer damage can be found at:

<http://www.agilent.com/find/tips>

1. Introduction

| | |
|---|----|
| What Does the WiMAX Measurement Application Do? | 10 |
|---|----|

2. Front and Rear Panel Features

| | |
|--|----|
| Front-Panel Features | 14 |
| Overview of key types. | 16 |
| Display Annotations | 20 |
| Rear-Panel Features | 22 |
| Front and Rear Panel Symbols | 25 |

3. Making 802.16 OFDMA Measurements

| | |
|---|----|
| Setting Up and Making a Measurement | 29 |
| Making the Initial Signal Connection | 29 |
| Using Analyzer Mode and Measurement Presets | 29 |
| The 3 Steps to Set Up and Make Measurements. | 29 |
| Channel Power Measurements | 31 |
| Setting the DUT (Example). | 32 |
| Measurement Procedure | 32 |
| Adjacent Channel Power Ratio Measurements | 37 |
| Setting the DUT (Example). | 37 |
| Measurement Procedure | 38 |
| Spectrum Emission Mask Measurements | 41 |
| Setting the DUT (Example). | 41 |
| Measurement Procedure | 42 |
| Troubleshooting Hints | 45 |
| Spurious Emissions Measurement | 47 |
| Setting the DUT (Example). | 47 |
| Measurement Procedure | 48 |
| Occupied Bandwidth Measurements | 53 |
| Setting the DUT (Example). | 53 |
| Measurement Procedure | 54 |
| Troubleshooting Hints | 55 |
| Power vs. Time Measurements | 57 |
| Configuring the Measurement System | 57 |
| Setting the DUT (Example). | 57 |
| Measurement Procedure | 58 |
| Modulation Analysis Measurements | 61 |
| Setting the DUT (Example). | 61 |
| Measurement Procedure | 62 |
| Power Statistics CCDF Measurements | 75 |
| Setting the DUT (Example). | 75 |
| Measurement Procedure | 76 |
| Troubleshooting Hints | 77 |
| Monitor Spectrum Measurements | 79 |
| Setting the DUT (Example). | 79 |
| Measurement Procedure | 80 |
| Waveform (Time Domain) Measurements | 83 |
| Setting the DUT (Example). | 83 |

| | |
|--|-----|
| Measurement Procedure | 84 |
| 4. Using Option BBA Baseband I/Q Inputs | |
| Baseband I/Q Measurements Available for X-Series Signal Analyzers. | 90 |
| Baseband I/Q Measurement Overview. | 92 |
| 5. Interpreting Error Codes | |
| 6. Concepts | |
| 802.16 OFDMA Overview. | 98 |
| IEEE 802.16 OFDMA Mobile | 99 |
| WiBro | 99 |
| The OFDMA Frame Structure | 100 |
| OFDMA Slots. | 102 |
| OFDMA Subchannels and Bursts. | 103 |
| OFDMA Zones. | 104 |
| A Summary Comparison of OFDMA and OFDM. | 105 |
| Measuring the Frequency Spectrum | 106 |
| Measuring the Wideband Spectrum | 106 |
| Measuring the Narrowband Spectrum | 106 |
| Finding Frames and Triggering Measurements | 108 |
| Finding the Trigger Level | 108 |
| Introducing a Trigger Delay | 109 |
| Capturing Signals In Real Time | 110 |
| Verifying OFDMA signal Impairments | 111 |
| Demodulating and Troubleshooting the Subframe. | 112 |
| Configuring the Signal Analyzer for Demodulating a WiMAX Signal | 112 |
| Verifying and Troubleshooting OFDM signals. | 118 |
| Time Gating Concepts | 120 |
| Introduction: Using Time Gating on a Simplified Digital Radio Signal | 120 |
| How Time Gating Works | 122 |
| Measuring a Complex/Unknown Signal. | 127 |
| “Quick Rules” for Making Time-Gated Measurements | 132 |
| Using the Edge Mode or Level Mode for Triggering | 135 |
| Noise Measurements Using Time Gating | 136 |
| Troubleshooting Symbols and Improving Demodulation | 137 |
| Demodulating Specific Time and Frequency Intervals. | 137 |
| Correcting Signal Imperfections. | 139 |
| Uncovering IQ Errors | 142 |
| 802.16 OFDMA Measurement Concepts. | 146 |
| Adjacent Channel Power Ratio (ACPR/ACLR) Measurement Concepts | 146 |
| Channel Power Measurement Concepts | 148 |
| IQ Waveform (Time Domain) Measurement Concepts | 148 |
| Modulation Analysis Concepts. | 149 |
| Monitor Spectrum Measurement Concepts | 151 |
| Occupied Bandwidth Measurement Concepts | 152 |
| Power Stat CCDF Measurement Concepts. | 153 |
| Power vs. Time Measurement Concepts. | 154 |

Contents

| | |
|--|-----|
| Spectrum Emission Mask Measurement Concepts | 155 |
| Spurious Emissions Measurement Concepts. | 156 |
| Baseband I/Q Inputs (Option BBA) Measurement Concepts | 158 |
| What are Baseband I/Q Inputs? | 158 |
| What are Baseband I/Q Signals? | 159 |
| Why Make Measurements at Baseband? | 159 |
| Selecting Input Probes for Baseband Measurements | 160 |
| Baseband I/Q Measurement Views | 161 |
| Other Sources of Measurement Information | 163 |
| Instrument Updates at www.agilent.com | 163 |
| Appendix A | 164 |
| Agilent WiMAX Frequency and Time Parameter Table. | 164 |
| Appendix B | 167 |
| WiMAX Standard Selection Preset Values | 167 |

7. References

This chapter provides overall information on the WiMAX-OFDMA measurement application. WiMAX-OFDMA consists of two wireless technologies: 802.16 OFDMA and WiBro. This chapter briefly describes WiMAX-OFDMA standards and N9075A measurements, .

What Does the WiMAX Measurement Application Do?

WiMAX-OFDMA supports the 802.16 OFDMA wireless standard and WiBro wireless technology.

The IEEE 802.16 OFDMA wireless standard supports fixed and mobile wireless access (BWA) systems for metropolitan and area networks. The IEEE 802.16 standard is an OFDMA based system that supports a range of bandwidths (e.g. 1.25 MHz, 10 MHz, and 20 MHz) with fixed subcarrier spacing through use of a scalable architecture. The scalable architecture uses a scalable subchannelization structure with variable Fast Fourier Transform (FFT) sizes, where the FFT sizes scale with bandwidth to keep subcarrier spacing fixed.)

WiBro is a wireless broadband internet technology. WiBro base stations will offer an aggregate data throughput of 30 to 50 Mbits/s and cover a radius of 1 - 5 km, enabling portable internet usage within range of the base station. WiBro also offers Quality of Service (QoS). QoS enables WiBro to stream video content and other loss-sensitive data in a reliable manner. WiBro is a proprietary technology and its use of licensed spectrum, which may not be available globally, may keep it from being implemented as an international standard. While WiBro is exacting in its requirements, from spectrum use to equipment design, WiMAX-OFDMA leaves much of this up to the equipment provider, while providing sufficient detail to ensure interoperability between designs.

The WiMAX measurement application supports the following standards:

- IEEE 802.16-2004 IEEE Standard for Local and metropolitan area networks Part 16: Air Interface for Fixed Broadband Wireless Access Systems
- IEEE P802.16-2004/Cor1/D5 (“Draft Corrigendum to IEEE Standard for Local and Metropolitan Area Networks - Part 16: Air Interface for Fixed Broadband Wireless Access Systems”).
- IEEE 802.16f-2005 IEEE Standard for Local and Metropolitan Area Networks - Part 16: Air Interface for Fixed Broadband Wireless Access Systems--Amendment 1--Management Information Base
- WiBro (Korean mobile WiMAX OFDMA service)

The following measurements are made using the WiMAX application:

- Monitor Spectrum
- Channel Power
- Occupied Bandwidth
- ACP
- Spectrum Emission Mask
- Spurious Emissions
- Power Stat CCDF
- Waveform
- Power vs. Time
- Modulation Analysis

Introduction

What Does the WiMAX Measurement Application Do?

- [“Front-Panel Features” on page 14](#)
- [“Display Annotations” on page 20](#)
- [“Rear-Panel Features” on page 22](#)
- [“Front and Rear Panel Symbols” on page 25](#)

Front-Panel Features

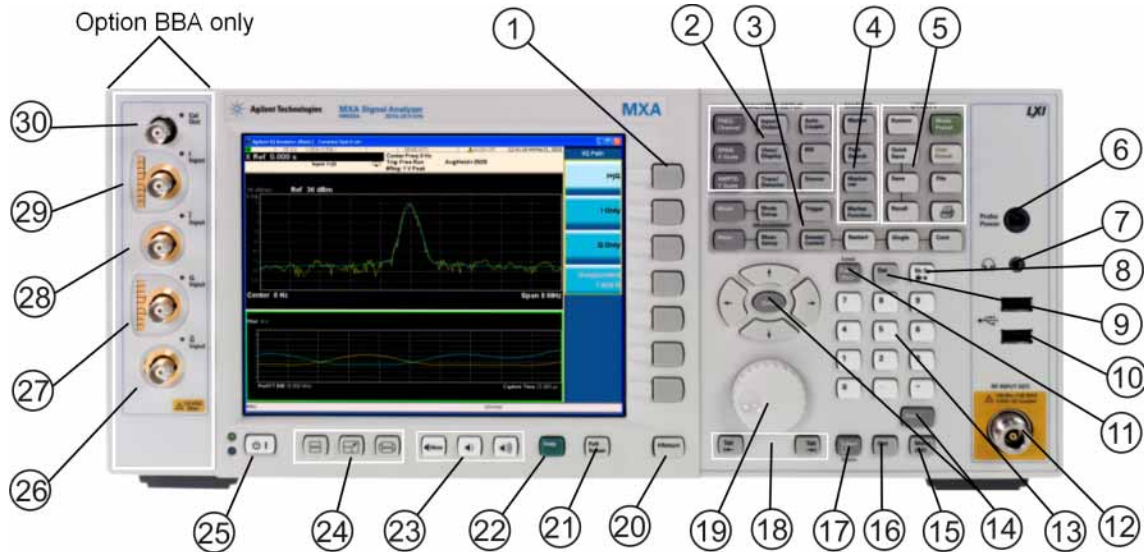

| Item | | Description |
|------|---------------------|--|
| # | Name | |
| 1 | Menu Keys | Key labels appear to the left of the menu keys to identify the current function of each key. The displayed functions are dependent on the currently selected Mode and Measurement, and are directly related to the most recent key press. |
| 2 | Analyzer Setup Keys | These keys set the parameters used for making measurements in the current Mode and Measurement. |
| 3 | Measurement Keys | These keys select the Mode, and the Measurement within the mode. They also control the initiation and rate of recurrence of measurements. |
| 4 | Marker Keys | Markers are often available for a measurement, to measure a very specific point/segment of data within the range of the current measurement data. |
| 5 | Utility Keys | These keys control system-wide functionality such as: <ul style="list-style-type: none"> • instrument configuration information and I/O setup, • printer setup and printing, • file management, save and recall, • instrument presets. |
| 6 | Probe Power | Supplies power for external high frequency probes and accessories. |
| 7 | Headphones Output | Headphones can be used to hear any available audio output. |
| 8 | Back Space Key | Press this key to delete the previous character when entering alphanumeric information. It also works as the Back key in Help and Explorer windows. |

| Item | | Description |
|------|------------------------|--|
| # | Name | |
| 9 | Delete Key | Press this key to delete files, or to perform other deletion tasks. |
| 10 | USB Connectors | Standard USB 2.0 ports, Type A. Connect to external peripherals such as a mouse, keyboard, DVD drive, or hard drive. |
| 11 | Local/Cancel/(Esc) Key | <p>If you are in remote operation, Local:</p> <ul style="list-style-type: none"> • returns instrument control from remote back to local (the front panel). • turns the display on (if it was turned off for remote operation). • can be used to clear errors. (Press the key once to return to local control, and a second time to clear error message line.) <p>If you have not already pressed the units or Enter key, Cancel exits the currently selected function without changing its value.</p> <p>Esc works the same as it does on a PC keyboard. It:</p> <ul style="list-style-type: none"> • exits Windows dialogs • clears errors • aborts printing • cancels operations. |
| 12 | RF Input | Connector for inputting an external signal. Make sure that the total power of all signals at the analyzer input does not exceed +30 dBm (1 watt). |
| 13 | Numeric Keypad | Enters a specific numeric value for the current function. Entries appear on the upper left of the display, in the measurement information area. |
| 14 | Enter and Arrow Keys | <p>The Enter key terminates data entry when either no unit of measure is needed, or you want to use the default unit.</p> <p>The arrow keys:</p> <ul style="list-style-type: none"> • Increment and decrement the value of the current measurement selection. • Navigate help topics. • Navigate, or make selections, within Windows dialogs. • Navigate within forms used for setting up measurements. • Navigate within tables. <p>NOTE The arrow keys cannot be used to move a mouse pointer around on the display.</p> |
| 15 | Menu/ (Alt) Key | Alt works the same as a PC keyboard. Use it to change control focus in Windows pull-down menus. |
| 16 | Ctrl Key | Ctrl works the same as a PC keyboard. Use it to navigate in Windows applications, or to select multiple items in lists. |
| 17 | Select / Space Key | Select is also the Space key and it has typical PC functionality. For example, in Windows dialogs, it selects files, checks and unchecks check boxes, and picks radio button choices. It opens a highlighted Help topic. |
| 18 | Tab Keys | Use these keys to move between fields in Windows dialogs. |
| 19 | Knob | Increments and decrements the value of the current active function. |
| 20 | Return Key | Exits the current menu and returns to the previous menu. Has typical PC functionality. |

Front and Rear Panel Features
Front-Panel Features

| Item | | Description |
|------|----------------------|--|
| # | Name | |
| 21 | Full Screen Key | Pressing this key turns off the softkeys to maximize the graticule display area. Press the key again to restore the normal display. |
| 22 | Help Key | Initiates a context-sensitive Help display for the current Mode. Once Help is accessed, pressing a front panel key brings up the help topic for that key function. |
| 23 | Speaker Control Keys | Enables you to increase or decrease the speaker volume, or mute it. |
| 24 | Window Control Keys | These keys select between single or multiple window displays. They zoom the current window to fill the data display, or change the currently selected window. They can be used to switch between the Help window navigation pane and the topic pane. |
| 25 | Power Standby/ On | Turns the analyzer on. A green light indicates power on. A yellow light indicates standby mode. <div style="background-color: #cccccc; padding: 2px; display: inline-block; margin-bottom: 5px;">NOTE</div> The front-panel switch is a standby switch, not a LINE switch (disconnecting device). The analyzer continues to draw power even when the line switch is in standby. The main power cord can be used as the system disconnecting device. It disconnects the mains circuits from the mains supply. |
| 26 | Q Input | Input port for the Q channel when in differential mode. ^a |
| 27 | Q Input | Input port for the Q channel for either single or differential mode. ^a |
| 28 | I Input | Input port for the I channel when in differential mode. ^a |
| 29 | I Input | Input port for the I channel for either single or differential mode. ^a |
| 30 | Cal Out | Output port for calibrating the I, I, Q and Q inputs and probes used with these inputs. ^a |

a. Status of the LED indicates whether the current state of the port is active (green) or is not in use (dark).

Overview of key types

The keys labeled **FREQ Channel**, **System**, and **Marker Functions** are all examples of front-panel keys.

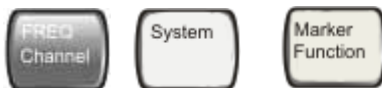

Most of the dark or light gray keys access menus of functions that are displayed along the right side of the display. These displayed key labels are next to a column of keys called menu keys.

Menu keys list functions based on which front-panel key was pressed last. These functions are also dependant on the current selection of measurement application (**Mode**) and measurement (**Meas**).

If the numeric value of a menu key function can be changed, it is called an active function. The function

Front and Rear Panel Features

Front-Panel Features

When a menu first appears, one key label is highlighted to show which key is the default selection. If you press **Marker Function**, the **Marker Function Off** key is the menu default key, and is highlighted.

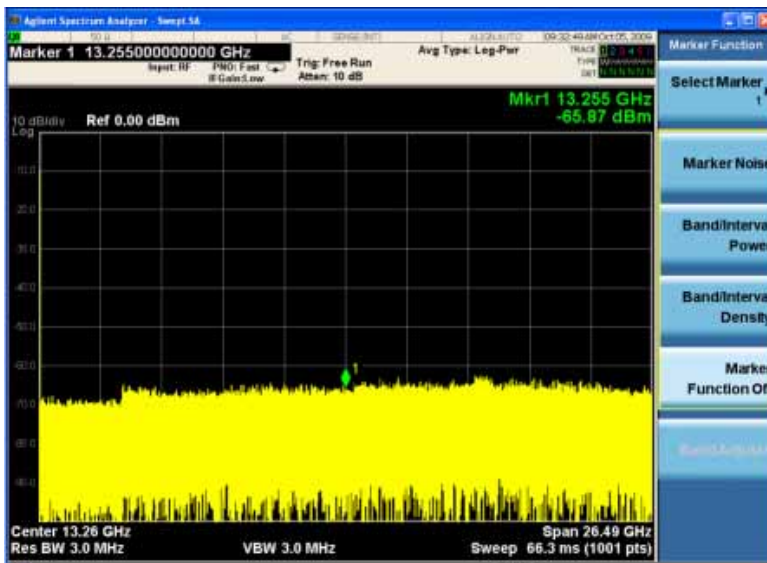

Some of the menu keys are grouped together by a yellow bar running behind the keys near the left side or by a yellow border around the group of keys. When you press a key within the yellow region, such as **Marker Noise**, the highlight moves to that key to show it has been selected. The keys that are linked are related functions, and only one of them can be selected at any one time. For example, a marker can only have one marker function active on it. So if you select a different function it turns off the previous selection. If the current menu is two pages long, the yellow bar or border could include keys on the second page of keys.

In some key menus, a key label is highlighted to show which key has been selected from multiple available choices. And the menu is immediately exited when you press one of the other keys. For example, when you press the **Select Trace** key (in the **Trace/Detector** menu), it brings up its own menu of keys. The **Trace 1** key is highlighted. When you press the **Trace 2** key, the highlight moves to that key and the screen returns to the **Trace/Detector** menu.

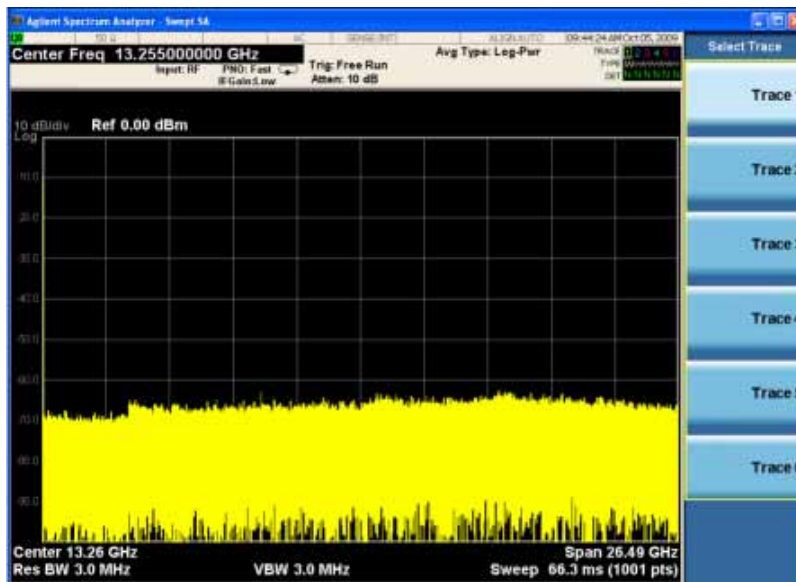

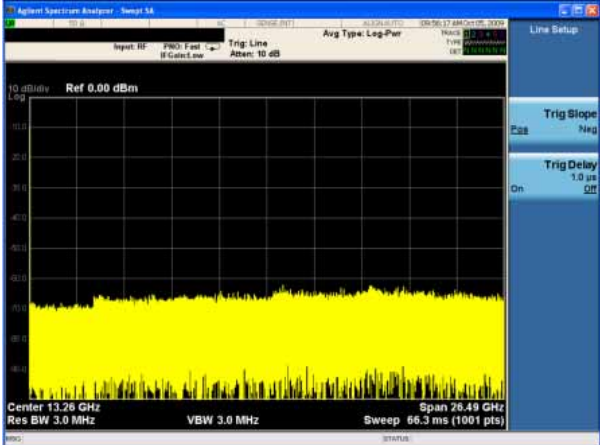
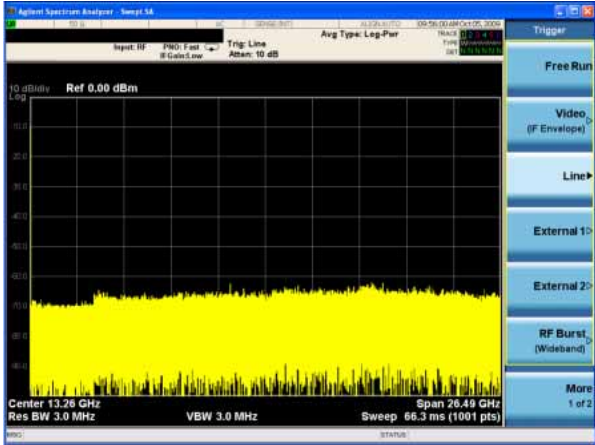
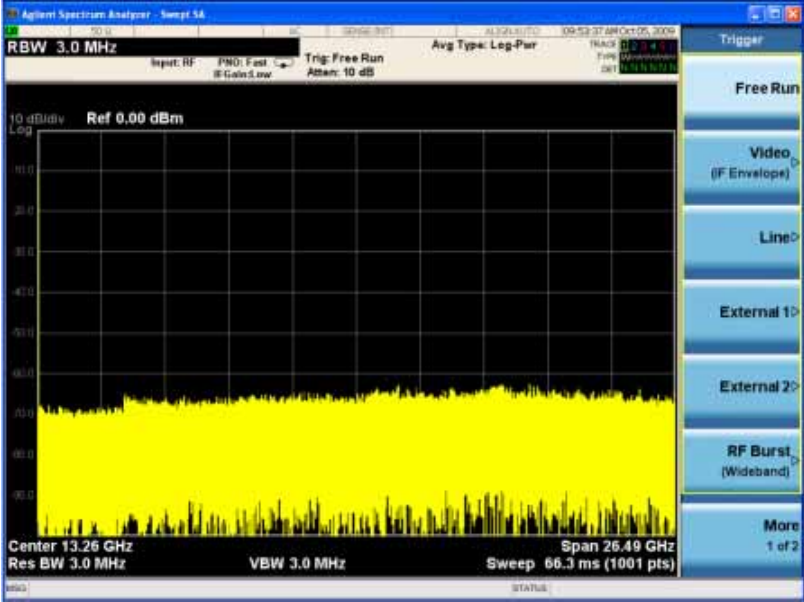

If a displayed key label shows a small solid-black arrow tip pointing to the right, it indicates that additional key menus are available. If the arrow tip is not filled in solid then pressing the key the first time selects that function. Now the arrow is solid and pressing it again brings up an additional menu of settings.

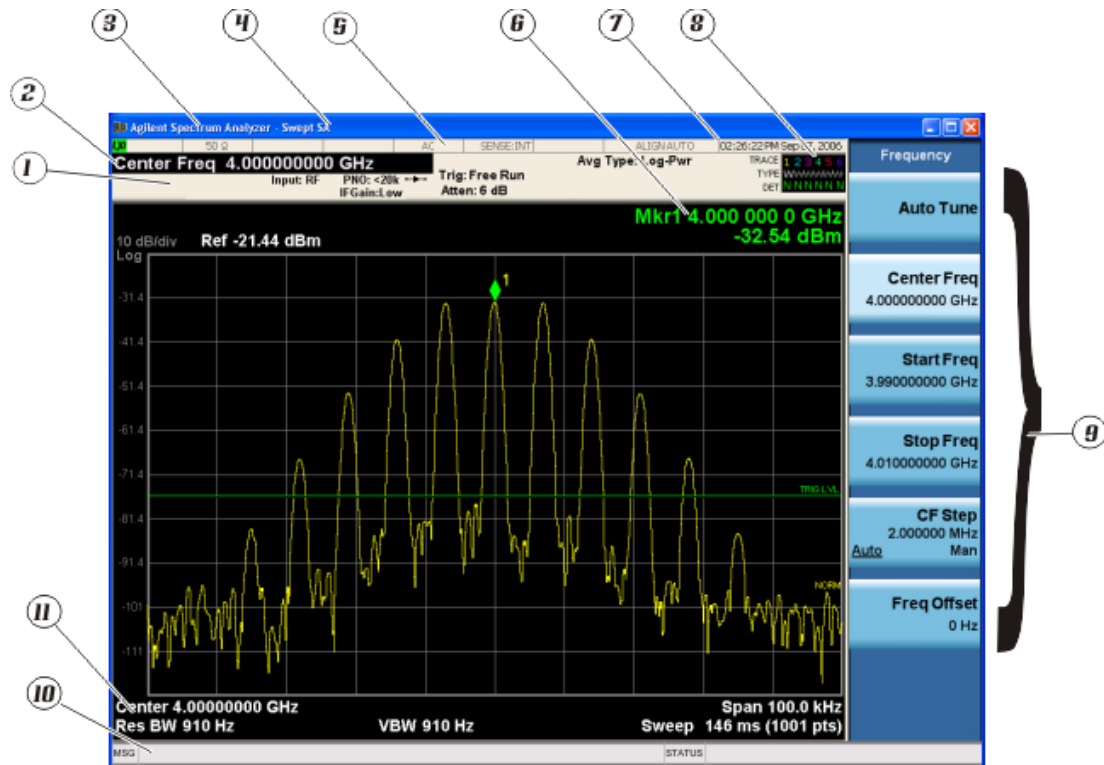

Display Annotations

This section describes the display annotation as it is on the Spectrum Analyzer Measurement Application display. Other measurement application modes will have some annotation differences.



| Item | Description | Function Keys |
|------|--|---|
| 1 | Measurement bar - Shows general measurement settings and information.   Indicates single/continuous measurement. Some measurements include limits that the data is tested against. A Pass/Fail indication may be shown in the lower left of the measurement bar. | All the keys in the Analyzer Setup part of the front panel. |
| 2 | Active Function (measurement bar) - when the current active function has a settable numeric value, it is shown here. | Currently selected front panel key. |
| 3 | Banner - shows the name of the selected measurement application and the measurement that is currently running. | Mode, Meas |
| 4 | Measurement title (banner) - shows title information for the current Measurement, or a title that you created for the measurement. | Meas View/Display, Display, Title |

| Item | Description | Function Keys |
|------|---|---|
| 5 | Settings panel - displays system information that is not specific to any one application. <ul style="list-style-type: none"> • Input/Output status - green LXI indicates the LAN is connected. RLTS indicate Remote, Listen, Talk, SRQ • Input impedance and coupling • Selection of external frequency reference • Setting of automatic internal alignment routine | Local and System, I/O Config Input/Output, Amplitude, System and others. |
| 6 | Active marker frequency, amplitude or function value. | Marker |
| 7 | Settings panel - time and date display. | System, Control Panel |
| 8 | Trace and detector information. | Trace/Detector, Clear Write (W) Trace Average (A) Max Hold (M) Min Hold (m) Trace/Detector, More, Detector, Average (A) Normal (N) Peak (P) Sample (S) Negative Peak (p) |
| 9 | Key labels that change based on the most recent key press. | Softkeys |
| 10 | Displays information, warning and error messages. Message area - single events, Status area - conditions. | |
| 11 | Measurement settings for the data currently being displayed in the graticule area. In the example above: center frequency, resolution bandwidth, video bandwidth, frequency span, sweep time and number of sweep points. | Keys in the Analyzer Setup part of the front panel. |

Rear-Panel Features

PXA, MXA and EXA with Option PC2

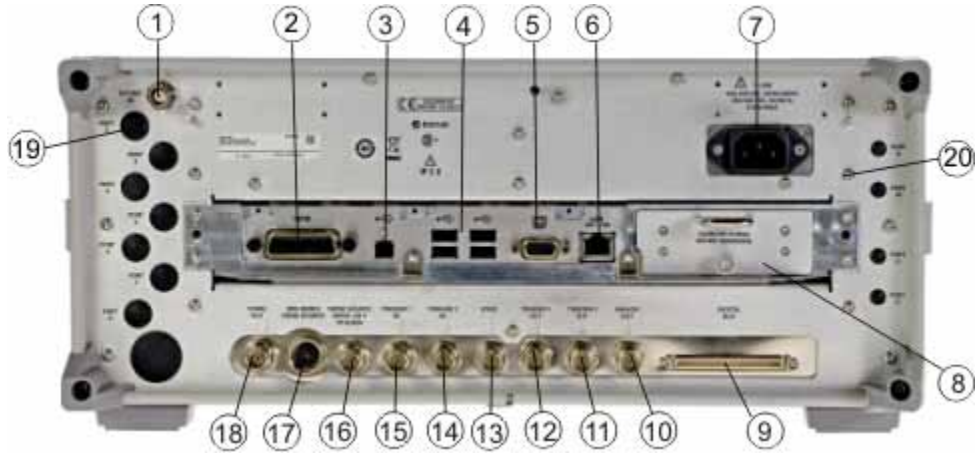

EXA



CXA

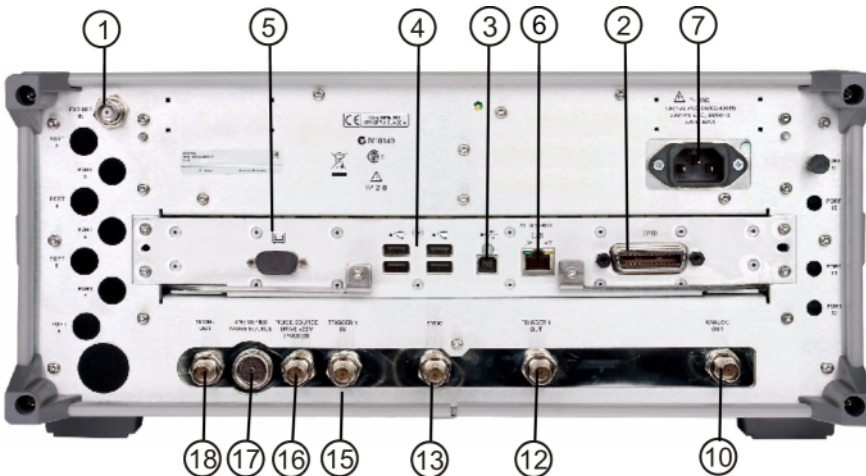

| Item | | Description |
|------|-----------------------------------|---|
| # | Name | |
| 1 | EXT REF IN | Input for an external frequency reference signal: For PXA – 1 to 50 MHz For MXA – 1 to 50 MHz For EXA – 10 MHz. For CXA – 10 MHz. |
| 2 | GPIB | A General Purpose Interface Bus (GPIB, IEEE 488.1) connection that can be used for remote analyzer operation. |
| 3 | USB Connector | USB 2.0 port, Type B. USB TMC (test and measurement class) connects to an external pc controller to control the instrument and for data transfers over a 480 Mbps link. |
| 4 | USB Connectors | Standard USB 2.0 ports, Type A. Connect to external peripherals such as a mouse, keyboard, printer, DVD drive, or hard drive. |
| 5 | MONITOR | Allows connection of an external VGA monitor. |
| 6 | LAN | A TCP/IP Interface that is used for remote analyzer operation. |
| 7 | Line power input | The AC power connection. See the product specifications for more details. |
| 8 | Removable Disk Drive | Standard on PXA and MXA. Optional on EXA. |
| 9 | Digital Bus | Reserved for future use. |
| 10 | Analog Out | For PXA option YAV: Screen Video Log Video Linear Video For PXA option EMC: Demod Audio |
| 11 | TRIGGER 2 OUT | A trigger output used to synchronize other test equipment with the analyzer. Configurable from the Input/Output keys. |
| 12 | TRIGGER 1 OUT | A trigger output used to synchronize other test equipment with the analyzer. Configurable from the Input/Output keys. |
| 13 | Sync | Reserved for future use. |
| 14 | TRIGGER 2 IN | Allows external triggering of measurements. |
| 15 | TRIGGER 1 IN | Allows external triggering of measurements. |
| 16 | Noise Source Drive +28 V (Pulsed) | For use with Agilent 346A, 346B, and 346C Noise Sources. |

Front and Rear Panel Features

Rear-Panel Features

| Item | | Description |
|------|-------------------------|---|
| # | Name | |
| 17 | SNS Series Noise Source | For use with Agilent N4000A, N4001A, N4002A Smart Noise Sources (SNS). |
| 18 | 10 MHz OUT | An output of the analyzer internal 10 MHz frequency reference signal. It is used to lock the frequency reference of other test equipment to the analyzer. |
| 19 | Preselector Tune Out | Reserved for future use. |
| 20 | Aux IF Out | For PXA options: CR3 Second IF Out CRP Arbitrary IF Out ALV Log Video |

Front and Rear Panel Symbols



This symbol is used to indicate power ON (green LED).



This symbol is used to indicate power STANDBY mode (yellow LED).



This symbol indicates the input power required is AC.



The instruction documentation symbol. The product is marked with this symbol when it is necessary for the user to refer to instructions in the documentation.



The CE mark is a registered trademark of the European Community.



The C-Tick mark is a registered trademark of the Australian Spectrum Management Agency.



This is a marking of a product in compliance with the Canadian Interference-Causing Equipment Standard (ICES-001).

This is also a symbol of an Industrial Scientific and Medical Group 1 Class A product (CISPR 11, Clause 4).



The CSA mark is a registered trademark of the CSA International.



This symbol indicates separate collection for electrical and electronic equipment mandated under EU law as of August 13, 2005. All electric and electronic equipment are required to be separated from normal waste for disposal (Reference WEEE Directive 2002/96/EC).



Indicates the time period during which no hazardous or toxic substance elements are expected to leak or deteriorate during normal use. Forty years is the expected useful life of the product.



This symbol on all primary and secondary packaging indicates compliance to China standard GB 18455-2001.

To return unwanted products, contact your local Agilent office, or see <http://www.agilent.com/environment/product/> for more information.

Front and Rear Panel Features
Front and Rear Panel Symbols

This chapter describes procedures used for making measurements of equipment operating per IEEE 802.16 OFDMA, including WiMAX and WiBro BS or MS. Instructions to help you set up and perform the measurements are provided, and examples of OFDMA measurement results are shown.

This chapter begins with instructions common to all measurements, details all OFDMA measurements available by pressing the **MEASURE** key. For information specific to individual measurements refer to the sections at the page numbers below.

- [“Setting Up and Making a Measurement” on page 29](#)
- [“Channel Power Measurements” on page 31](#)
- [“Adjacent Channel Power Ratio Measurements” on page 37](#)
- [“Spectrum Emission Mask Measurements” on page 41](#)
- [“Spurious Emissions Measurement” on page 47](#)
- [“Occupied Bandwidth Measurements” on page 53](#)
- [“Power vs. Time Measurements” on page 57](#)
- [“Modulation Analysis Measurements” on page 61](#)
- [“Power Statistics CCDF Measurements” on page 75](#)
- [“Monitor Spectrum Measurements” on page 79](#)
- [“Waveform \(Time Domain\) Measurements” on page 83](#)

All the measurements above are referred to as one-button measurements. When you press the key to select a measurement it will become active, using settings and displays unique to that measurement. Data acquisition will automatically begin when trigger requirements, if any, are met.

Setting Up and Making a Measurement

Making the Initial Signal Connection

CAUTION

Before connecting a signal to the analyzer, make sure the analyzer can safely accept the signal level provided. The signal level limits are marked next to the RF Input connectors on the front panel.

See the Input Key menu for details on selecting input ports and the AMPTD Y Scale menu for details on setting internal attenuation to prevent overloading the analyzer.

Using Analyzer Mode and Measurement Presets

To set your current measurement mode to a known factory default state, press **Mode Preset**. This initializes the analyzer by returning the mode setup and all of the measurement setups in the mode to the factory default parameters.

To preset the parameters that are specific to an active, selected measurement, press **Meas Setup, Meas Preset**. This returns all the measurement setup parameters to the factory defaults, but only for the currently selected measurement.

The 3 Steps to Set Up and Make Measurements

All measurements can be set up using the following three steps. The sequence starts at the Mode level, is followed by the Measurement level, then finally, the result displays may be adjusted.

Table 3-1 The 3 Steps to Set Up and Make a Measurement

| Step | Action | Notes |
|---|---|--|
| 1. Select and Set Up the Mode | a. Press Mode b. Press a mode key, like Spectrum Analyzer, W-CDMA with HSDPA/HSUPA, or GSM/EDGE . c. Press Mode Preset . d. Press Mode Setup | All licensed, installed modes available are shown under the Mode key. Using Mode Setup , make any required adjustments to the mode settings. These settings will apply to all measurements in the mode. |
| 2. Select and Set Up the Measurement | a. Press Meas . b. Select the specific measurement to be performed. c. Press Meas Setup | The measurement begins as soon as any required trigger conditions are met. The resulting data is shown on the display or is available for export. Use Meas Setup to make any required adjustment to the selected measurement settings. The settings only apply to this measurement. |

Setting Up and Making a Measurement

Table 3-1 The 3 Steps to Set Up and Make a Measurement

| Step | Action | Notes |
|---|---|--|
| 3. Select and Set Up a View of the Results | Press View/Display . Select a display format for the current measurement data. | Depending on the mode and measurement selected, other graphical and tabular data presentations may be available. X-Scale and Y-Scale adjustments may also be made now. |

NOTE A setting may be reset at any time, and will be in effect on the next measurement cycle or view.

Table 3-2 Main Keys and Functions for Making Measurements

| Step | Primary Key | Setup Keys | Related Keys |
|---|---------------------|------------------------------------|---|
| 1. Select and set up a mode. | Mode | Mode Setup, FREQ Channel | System |
| 2. Select and set up a measurement. | Meas | Meas Setup | Sweep/Control, Restart, Single, Cont |
| 3. Select and set up a view of the results. | View/Display | SPAN X Scale, AMPTD Y Scale | Peak Search, Quick Save, Save, Recall, File, Print |

Channel Power Measurements

This chapter explains how to make channel power measurements on OFDMA Base Stations (BS) or Mobile Stations (MS). This test measures the total RF power present in the selected channel BW. The results are shown in a graph window and in a text window.

NOTE Because OFDMA is bursted, you must use the Gate function to obtain valid results when measuring 802.16 OFDMA signals. See the measurement procedure for details.

TIP When a bursted signal such as 802.16 OFDMA is being measured, it is recommended to use RF Burst trigger for trigger mode. In this case, increasing the average number (**Avg Number**) has no effect on increasing repeatability, while increasing sweep time is very effective toward increasing measurement repeatability. Increasing sweep time yields more stable results, however a corresponding increase in measurement time can be expected.

Configuring the Measurement System

The DUT under test must be set to transmit the RF power remotely through the system controller. This transmitting signal is connected to the RF input port of the analyzer. Connect the equipment as shown.

Figure 3-1 Channel Power Measurement System

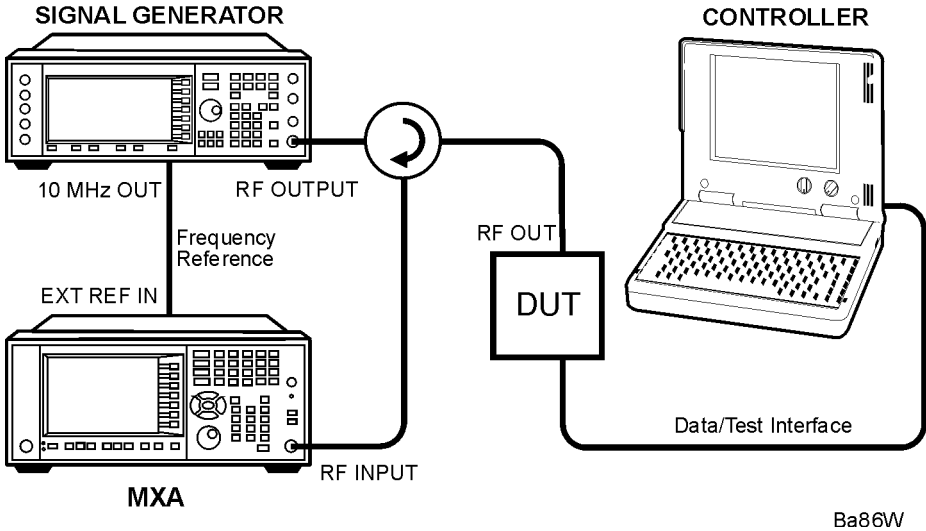

1. Using the appropriate cables, adapters, and circulator, connect the output signal from the DUT to the RF input port of the analyzer.
2. Connect the base transceiver station simulator or signal generator to the DUT through the circulator to initiate a link, if required.
3. Connect a BNC cable between the 10 MHz OUT port of the signal generator and the EXT REF IN

Channel Power Measurements

port of the analyzer.

4. Connect the system controller to the DUT through the data/test interface cable to control the DUT operation.
5. If used, connect the external Gate trigger signal to a rear-panel connector like External 1 or 2.

Setting the DUT (Example)

This example uses a signal generated using Agilent N7615B Signal Studio for 802.16 WiMAX. The specific signal used is the Downlink (TDD) example documented in the N7615B Signal Studio for 802.16 WiMAX Help Tutorial, having 1 DL PUSC Zone with 2 bursts.

Frequency: 2.5 GHz

Output Power: -15 dBm (at analyzer input)

Measurement Procedure

- Step 1.** Press **Mode, 802.16 OFDMA (WiMAX/Wibro)** to enable the OFDMA measurements.
- Step 2.** Press **Mode Preset** to preset the Mode. Only do this to return the measurement settings to a known state for all measurements in the OFDMA mode.
- Step 3.** If your DUT is a MS, or your signal of interest is an uplink (UL), press the **Mode Setup, Radio Device, MS** keys to enable OFDMA MS measurements. The default is **BS**.
- Step 4.** Press **FREQ Channel, 2.5, GHz** to set the center frequency to 2.5 GHz.
- Step 5.** Press **Meas, Channel Power** to initiate the channel power measurement.
- Step 6.** Press **Meas Setup, Meas Preset** to preset the measurement. This will return the measurement settings to a known state for only this measurement.

NOTE

The next several steps will set the Gate function to make a Channel Power measurement in the data burst of the OFDMA frame.

Gate settings made in any measurement persist for all measurements in the mode.

- Step 7.** Press **Sweep/Control, Gate, Gate View** and toggle it to **On**.
- Step 8.** Press **Gate View Sweep Time** and set it to 1 ms.
- Step 9.** Press **Gate Delay** and set it to 110 us. This sets Gate Start to begin after the Preamble.
- Step 10.** Press **Gate Length** and set it to 110 us, about the length of an OFDMA symbol.
- Step 11.** (Optional) Select your **Gate Source** trigger signal, if used. Instead of an external signal, this measurement example uses the default gate source, the **Periodic Timer** (Frame), which is set to a period of 5 ms, and synchronizes with the RF burst. If you want to use another gate source, like an external trigger signal, you can select

the correct input, like **External 1**, under the **Sweep/Control, Gate, More (1 of 2), Gate Source** menu. You will need to adjust the signal parameters under the same menu.

Step 12. Press **Gate** and toggle it to **On**.

The Channel Power measurement result should look like **Figure 3-2**. The graph window and the text window show the absolute power and its mean power spectral density values over 20MHz.

Figure 3-2 Channel Power Measurement Result - Gate View w/Gate in Data Burst

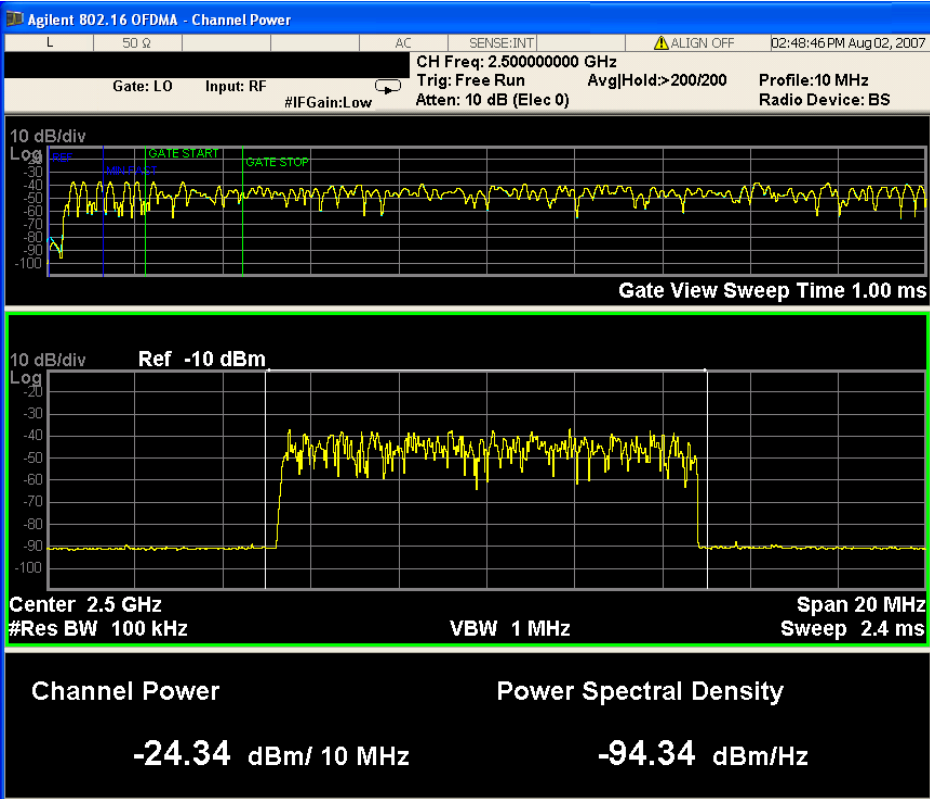

NOTE The next several steps will set the Gate function to make a Channel Power measurement in the Preamble of the signal. In this example, the gate will be set to occur in the second data burst of the OFDMA frame.

Gate settings made in any measurement persist for all measurements in the mode.

Step 13. Press **Gate View Sweep Time** and set it to 8 ms.

Step 14. Press **Gate Delay** and set it to 5 ms. This setting allows Gate Start to begin just before the Preamble of the second burst, and avoids setting the Gate Start before the Max Fast limit in the first burst, insuring an accurate measurement.

TIP For best results, always set **Gate Delay** to position Gate Start after the Max

Channel Power Measurements

Fast limit to allow the LO to “settle”.

- Step 15.** Press **Gate Length** and set it to 110 us, about the length of the OFDMA Preamble (one symbol).

The Gate View result should look like [Figure 3-4](#).

Figure 3-3 Channel Power Measurement Result - Gate View w/Gate in Preamble of Second Burst

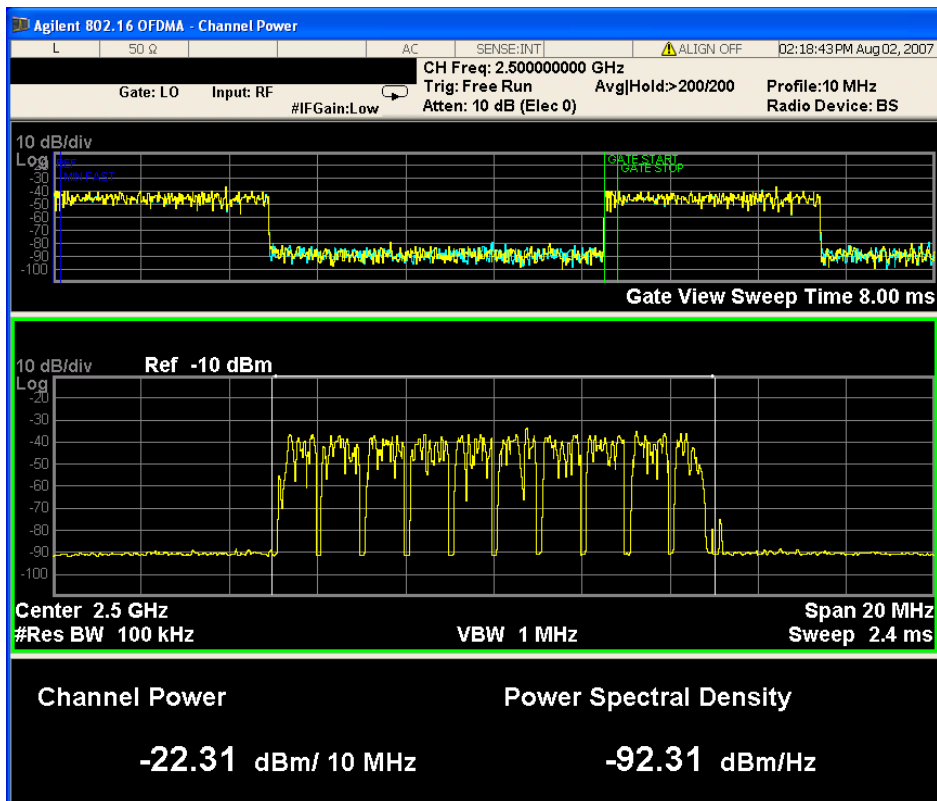

- Step 16.** (Optional) Press **View/Display, Bar Graph** to display the Channel Power Bar Graph view.

The Bar Graph view result should look like [Figure 3-4](#).

Figure 3-4

Channel Power Measurement Result - Bar Graph View (Default)

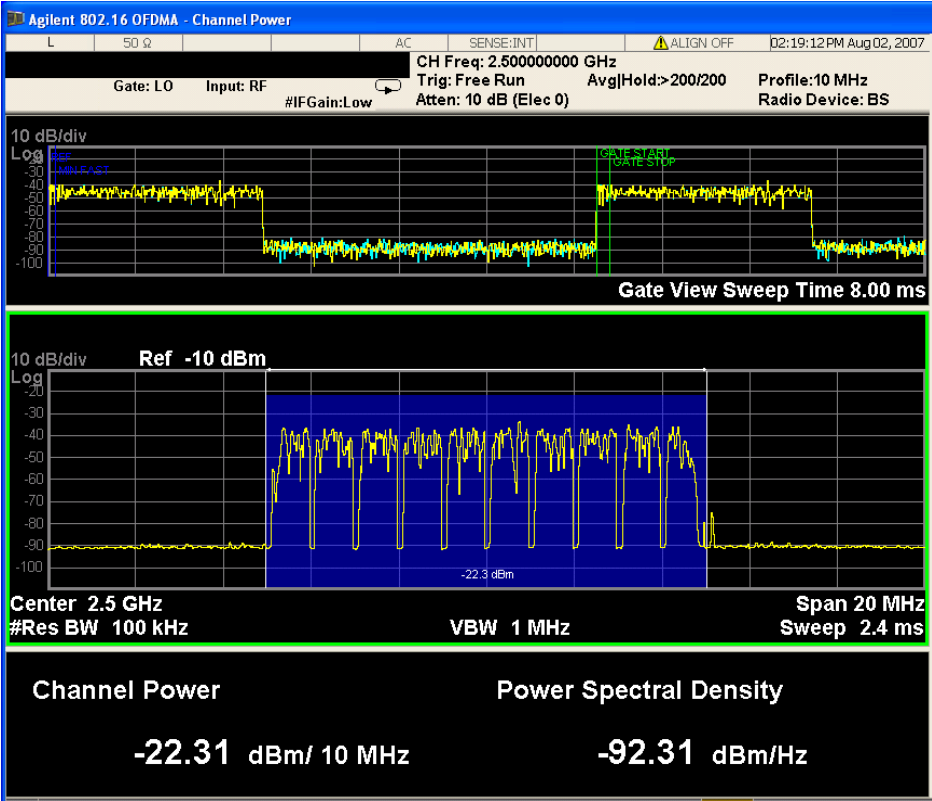

Step 17. (Optional) Press **Meas Setup** to see the keys that are available to change measurement parameters from their default condition. For instance, you can change the Integration BW from the default 10 MHz by pressing the **Integ BW** key.

If you have a problem, and get an error message, see the “*Error Messages Guide*”.

For more information on Time Gating see “*Time Gating Concepts*” on page 120.

Channel Power Measurements

Adjacent Channel Power Ratio Measurements

This chapter explains how to make Adjacent Channel Leakage Power Ratio (ACLR or ACPR) measurements on 802.16 OFDMA Base Stations (BS) or Mobile Stations (MS). ACPR is a measurement of the amount of interference, or power, in an adjacent frequency channel. The results are shown as a bar graph or as spectrum data, with measurement data at specified offsets.

NOTE Because OFDMA is bursted, you must use the Gate function to obtain valid results when measuring 802.16 OFDMA signals. See the measurement procedure for details.

The DUT under test must be set to transmit the RF power remotely through the system controller. This transmitting signal is connected to the RF input port of the analyzer. Connect the equipment as shown.

Figure 3-5 Channel Power Measurement System

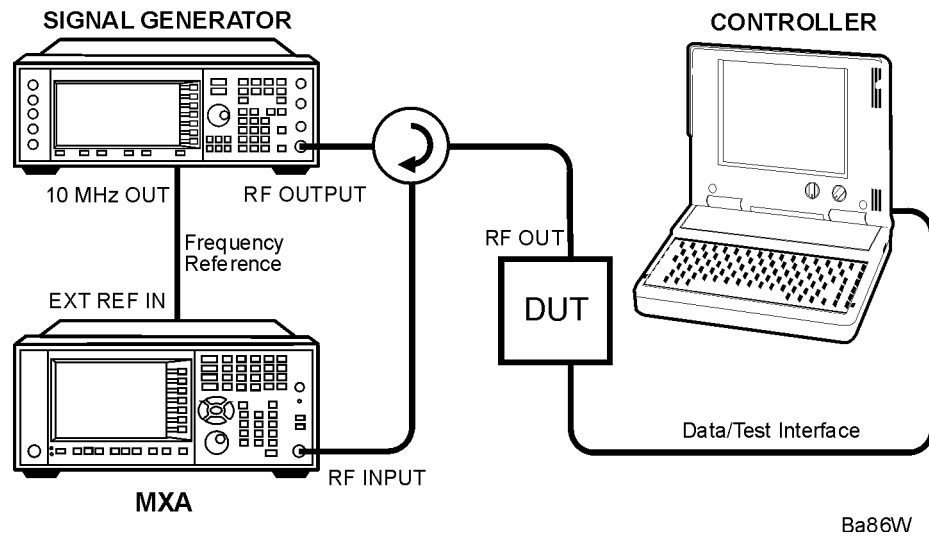

1. Using the appropriate cables, adapters, and circulator, connect the output signal from the DUT to the RF input port of the analyzer.
2. Connect the base transceiver station simulator or signal generator to the DUT through the circulator to initiate a link, if required.
3. Connect a BNC cable between the 10 MHz OUT port of the signal generator and the EXT REF IN port of the analyzer.
4. Connect the system controller to the DUT through the data/test interface cable to control the DUT operation.
5. If used, connect the external Gate trigger signal to a rear-panel connector like External 1 or 2.

Setting the DUT (Example)

This example uses a signal generated using Agilent N7615B Signal Studio for 802.16 WiMAX. The

Adjacent Channel Power Ratio Measurements

specific signal used is a Downlink (TDD) example, with 1 DL PUSC Zone, and 2 bursts.

Frequency: 2.5 GHz

Output Power: -15 dBm (at analyzer input)

Measurement Procedure

- Step 1.** Press **Mode, 802.16 OFDMA (WiMAX/Wibro)** to enable the OFDMA measurements.
- Step 2.** Press **Mode Preset** to preset the Mode. Only do this to return the measurement settings to a known state for all measurements in the OFDMA mode.
- Step 3.** If your DUT is a MS, or your signal of interest is an uplink (UL), press the **Mode Setup, Radio Device, MS** keys to enable OFDMA MS measurements. The default is BS.
- Step 4.** Press **FREQ Channel, 2.5, GHz** to set the center frequency to 2.5 GHz.
- Step 5.** Press **Meas, ACP** to initiate the adjacent channel leakage power ratio measurement. A Spectrum display is shown, with white vertical lines to indicate the various offset settings, and a measurement summary below.
- Step 6.** Press **Meas Setup, Meas Preset** to preset the measurement. This will return the measurement settings to a known state for only this measurement.

NOTE The next several steps will set the Gate function to make an Adjacent Channel Power measurement in the data burst of the OFDMA frame.

Gate settings made in any measurement persist for all measurements in the mode.

- Step 7.** Press **Sweep/Control, Gate, Gate View** and toggle it to **On**.
- Step 8.** Press **Gate View Sweep Time** and set it to 1 ms.
- Step 9.** Press **Gate Delay** and set it to 110 us. This sets Gate Start to begin after the Preamble.

TIP For best results, always set **Gate Delay** to position Gate Start after Max Fast to allow the LO to “settle”.

- Step 10.** Press **Gate Length** and set it to 110 us, about the length of an OFDMA symbol.
- Step 11.** (Optional) Select your **Gate Source** trigger signal, if used. Instead of an external signal, this measurement example uses the default gate source, the **Periodic Timer** (Frame), which is set to a period of 5 ms, and synchronizes with the RF burst. If you want to use another gate source, like an external trigger signal, you can select the correct input, like **External 1**, under the **Sweep/Control, Gate, More (1 of 2), Gate Source** menu. You will need to adjust the signal parameters under the same menu.
- Step 12.** Press **Gate** and toggle **Gate** to **On**.

The Gate View of the ACP measurement result should look like Figure 3-6. A time domain waveform graph showing the Gate settings, and a spectrum graph (referenced to the total power) and a text window are displayed. The text window shows the absolute total power reference, while the lower and upper offset channel power levels are displayed in both absolute and relative readings.

Figure 3-6 Measurement Result - Gate View (Bar Graph)

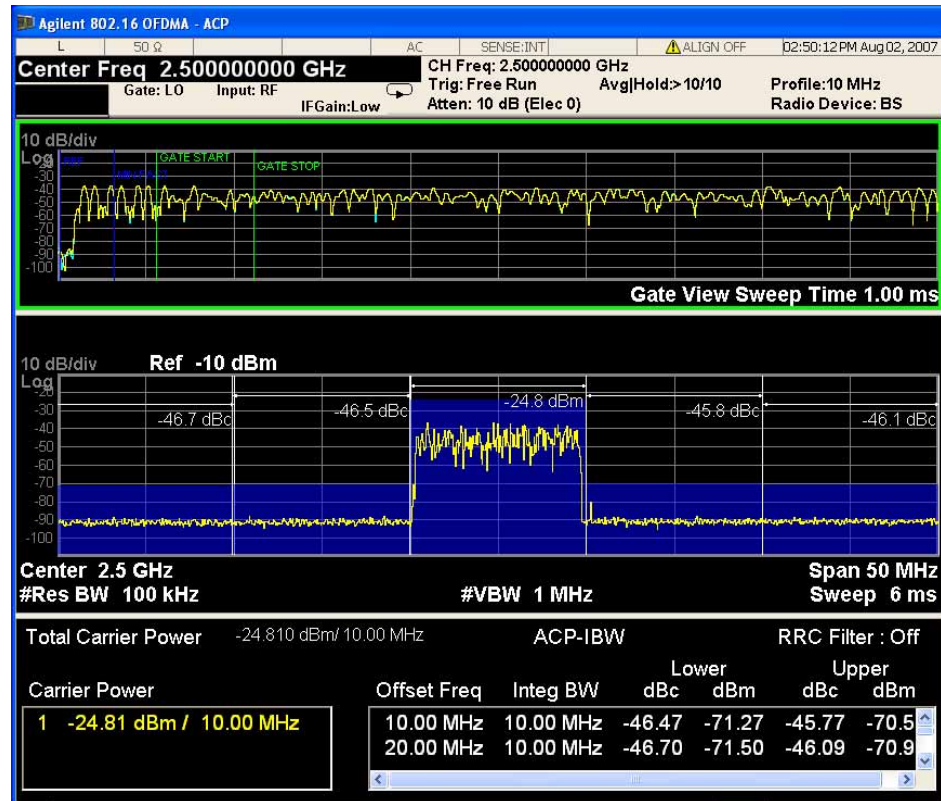

Step 13. (Optional) Press **Meas Setup**, **Noise Correction**, and toggle the key to **On**. **Noise Correction** can reduce the noise contribution of the analyzer to the measurement results as much as 10 dB. The correction will be valid for only the current measurement parameters.

CAUTION

To correctly use the **Noise Correction** feature, you **MUST** re-calibrate the correction (set to **Off**, then **On**) after **ANY** measurement parameters are changed. Failure to re-calibrate the **Noise Correction** will provide invalid data. When **Noise Correction** is **On**, the screen annotation **NCORR** is shown below the **Input**.

Step 14. (Optional) Press **AMPTD** and adjust the **Attenuation** to 0 dB to allow greater dynamic range for this level of input signal.

TIP

For the most accurate ACP measurement results, you maybe able to optimize the level of the signal measured by the analyzer. Adjust the input attenuation using the

Adjacent Channel Power Ratio Measurements

Up/Down keys, while watching the ACP levels shown at the offsets to see if the measurement results improve with another setting.

Step 15. (Optional) Press **View/Display, Bar Graph** and toggle the setting to **Off**, if desired.

Step 16. (Optional) Press **Meas Setup** to see the keys that are available to change the measurement parameters from the default condition, including **Limits**.

If you have a problem, and get an error message, see the “*Error Messages Guide*”.

For more information on Time Gating see “[Time Gating Concepts](#)” on page 120.

Spectrum Emission Mask Measurements

This chapter explains how to make spectrum emission mask (SEM) measurements on 802.16 OFDMA Base Stations (BS) or Mobile Stations (MS). SEM compares the total power level within the defined carrier bandwidth and the given offset channels on both sides of the carrier frequency, to levels allowed by the standard. Results of the measurement of each offset segment can be viewed separately.

NOTE Because OFDMA is bursty, you must use the Gate function to obtain valid results when measuring 802.16 OFDMA signals. See the measurement procedure for details.

The DUT under test must be set to transmit the RF power remotely through the system controller. This transmitting signal is connected to the RF input port of the analyzer. Connect the equipment as shown.

Figure 3-7 Spectrum Emission Mask Measurement System

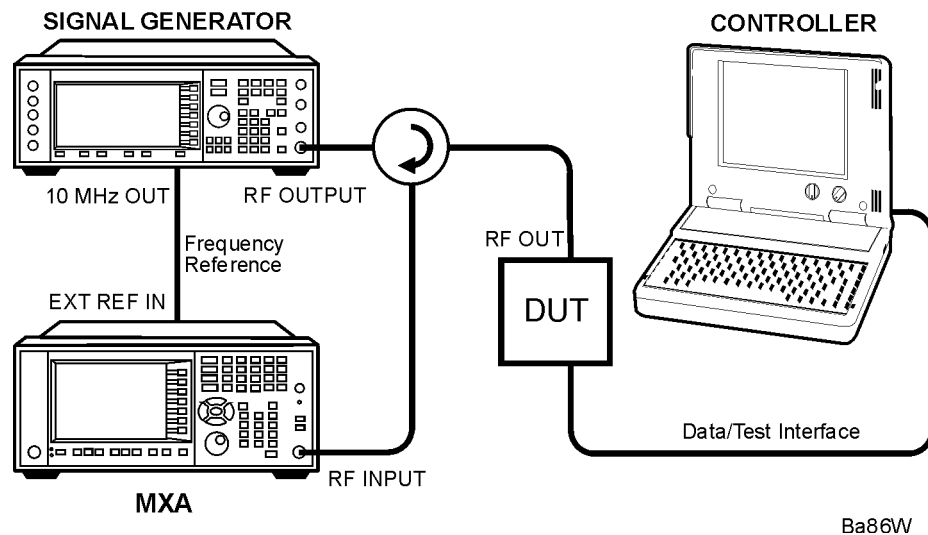

1. Using the appropriate cables, adapters, and circulator, connect the output signal from the DUT to the RF input port of the analyzer.
2. Connect the base transceiver station simulator or signal generator to the DUT through the circulator to initiate a link, if required.
3. Connect a BNC cable between the 10 MHz OUT port of the signal generator and the EXT REF IN port of the analyzer.
4. Connect the system controller to the DUT through the data/test interface cable to control the DUT operation.
5. If used, connect the external Gate trigger signal to a rear-panel connector like External 1 or 2.

Setting the DUT (Example)

This example uses a signal generated using Agilent N7615B Signal Studio for 802.16 WiMAX. The

Spectrum Emission Mask Measurements

specific signal used is the Downlink (TDD) example from the N7615B Signal Studio for 802.16 WiMAX Help Tutorial: 1 DL PUSC Zone, 2 bursts.

Frequency: 2.5 GHz

Output Power: -15 dBm (at analyzer input)

Measurement Procedure

- Step 1.** Press **Mode, 802.16 OFDMA (WiMAX/Wibro)** to enable the OFDMA measurements.
- Step 2.** Press **Mode Preset** to preset the Mode. Only do this to return the measurement settings to a known state for all measurements in the OFDMA mode.
- Step 3.** If your DUT is a MS, or your signal of interest is an uplink (UL), press the **Mode Setup, Radio Device, MS** keys to enable OFDMA MS measurements. The default is BS.
- Step 4.** Press **FREQ Channel, 2.5, GHz** to set the center frequency to 2.5 GHz.
- Step 5.** Press **Meas, Spectrum Emission Mask** to initiate the spectrum emission mask measurement.
- Step 6.** Press **Meas Setup, Meas Preset** to preset the measurement. This will return the measurement settings to a known state for only this measurement.

NOTE The next several steps will set the Gate function to make a Spectrum Emission Mask measurement in the data burst of the OFDMA frame.

Gate settings made in any measurement persist for all measurements in the mode.

- Step 7.** Press **Sweep/Control, Gate, Gate View** and toggle it to **On**.
- Step 8.** Press **Gate View Sweep Time** and set it to 1 ms.
- Step 9.** Press **Gate Delay** and set it to 110 us. This sets Gate Start to begin after the Preamble.

TIP For best results, always set **Gate Delay** to position Gate Start after Max Fast to allow the LO to “settle”.

- Step 10.** Press **Gate Length** and set it to 110 us, about the length of an OFDMA symbol.
- Step 11.** (Optional) Select your **Gate Source** trigger signal, if used. Instead of an external signal, this measurement example uses the default gate source, the **Periodic Timer (Frame)**, which is set to a period of 5 ms, and synchronizes with the RF burst. If you want to use another gate source, like an external trigger signal, you can select the correct input, like **External 1**, under the **Sweep/Control, Gate, More (1 of 2), Gate Source** menu. You will need to adjust the signal parameters under the same menu.
- Step 12.** Press **Gate** and toggle **Gate** to **On**.

The Spectrum Emission Mask default measurement result should look like Figure 3-8. It is based on a Total Power measurement with an Absolute Power reference. The text window shows the reference total power and the absolute peak power levels which correspond to the frequency bands on both sides of the reference channel.

Figure 3-8 Spectrum Emission Mask (Total Pwr) Measurement Result - Relative Pwr Ref View

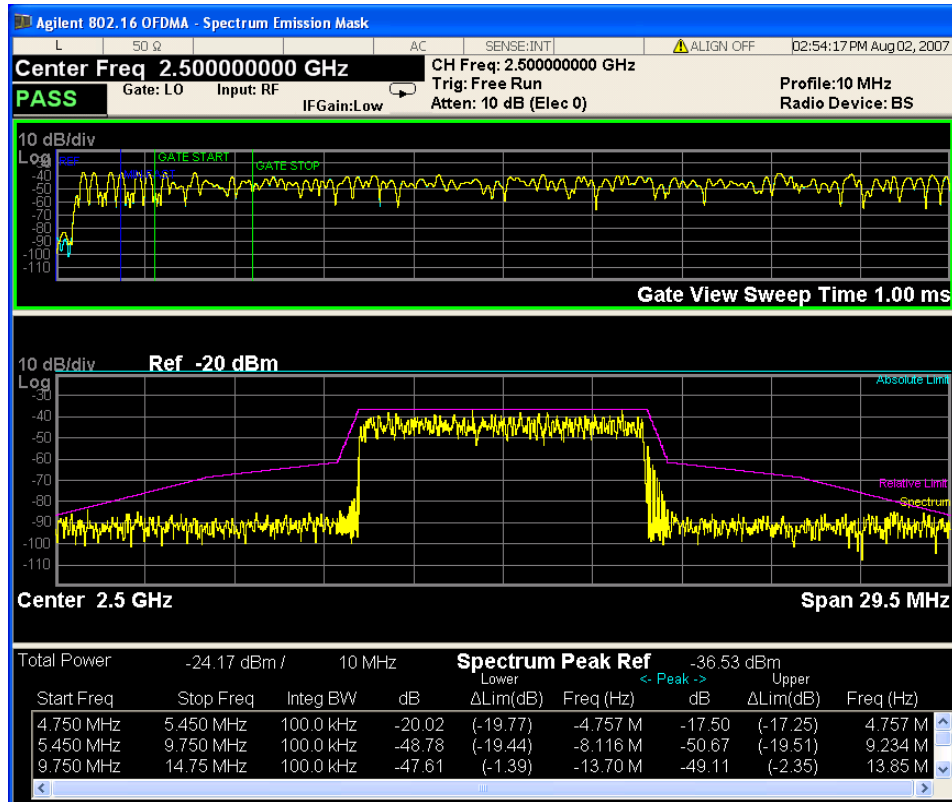

The **Relative Pwr Ref** result for an SEM measurement should look like Figure 3-9. The text window shows the reference total power and the relative power levels in dB which correspond to the frequency bands on both sides of the reference channel.

Spectrum Emission Mask Measurements

Step 13. Press **View/Trace** and select **Abs Pwr Freq** to display the Relative Power reference view for the spectrum emission mask measurement.

Figure 3-9

Spectrum Emission Mask (Total Pwr) Measurement Result - Abs Pwr Ref View

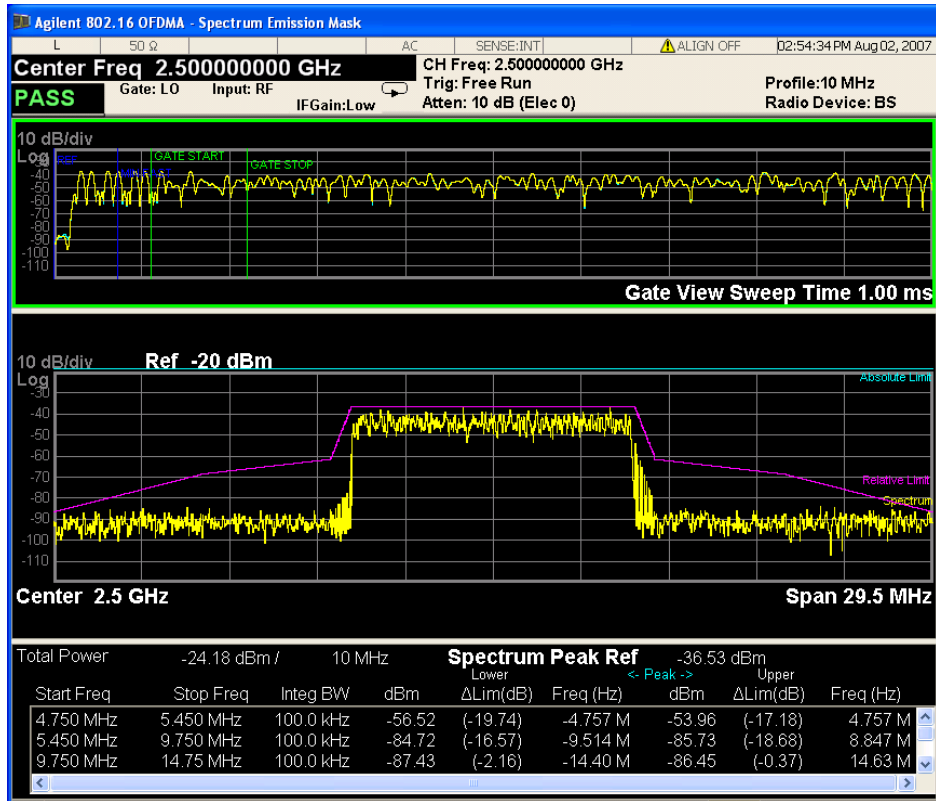

- Step 14.** Press **View/Trace** and select **Integrated Power** to display the Integrated Power view for the spectrum emission mask measurement.

Figure 3-10

Spectrum Emission Mask (Total Pwr) Measurement Result - Integrated Power View

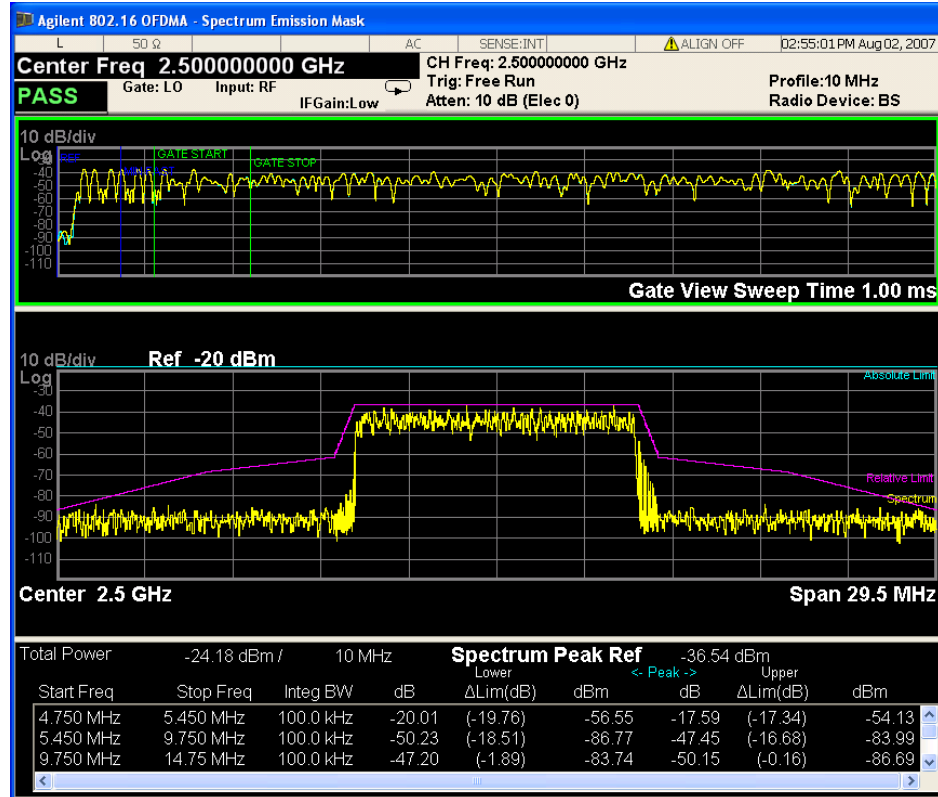

The Spectrum Emission Mask **Integrated Power** measurement result should look like [Figure 3-10](#). The text window shows the reference total power and the integrated power levels which correspond to the frequency bands on both sides of the reference channel.

- Step 15.** Press the **AMPLITUDE Y Scale**, and up or down arrow keys to a just the Ref Value until the spectrum trace is shown at a convenient scale for viewing.
- Step 16.** To change other measurement parameters, press **Meas Setup**. For example, you can change the **Meas Type** to **PSD Ref**:

Press **Meas Setup**, **Meas Type**, and select **PSD Ref** to display the Integrated Power view for the spectrum emission mask measurement with a PSD reference. The PSD reference is shown below the spectrum graph in dBm/Hz.

If you have a problem, and get an error message, see the “*Error Messages Guide*”.

For more information on Time Gating see “[Time Gating Concepts](#)” on page 120.

Troubleshooting Hints

This spectrum emission mask measurement can reveal degraded or defective parts in the transmitter section of the unit under test (UUT). The following examples are those areas to be checked further.

Spectrum Emission Mask Measurements

- Faulty DC power supply control of the transmitter power amplifier.
- RF power controller of the pre-power amplifier stage.
- I/Q control of the baseband stage.
- Some degradation in the gain and output power level of the amplifier due to the degraded gain control or increased distortion, or both.
- Some degradation of the amplifier linearity or other performance characteristics.

Power amplifiers are one of the final stage elements of a transmitter and are a critical part of meeting the important power and spectral efficiency specifications. Since spectrum emission mask measures the spectral response of the amplifier to a complex wideband signal, it is a key measurement linking amplifier linearity and other performance characteristics to the stringent system specifications.

Spurious Emissions Measurement

This section explains how to make Spurious Emission Measurements on a 802.16 OFDMA Base Station (BS) or Mobile Stations (MS). Spurious Emission (Spur) measurements identify and determine the power level of spurious emissions (spurs) in certain frequency bands.

The DUT under test must be set to transmit the RF power remotely through the system controller. This transmitting signal is connected to the RF input port of the instrument. Connect the equipment as shown.

Figure 3-11 Spectrum Emission Mask Measurement System

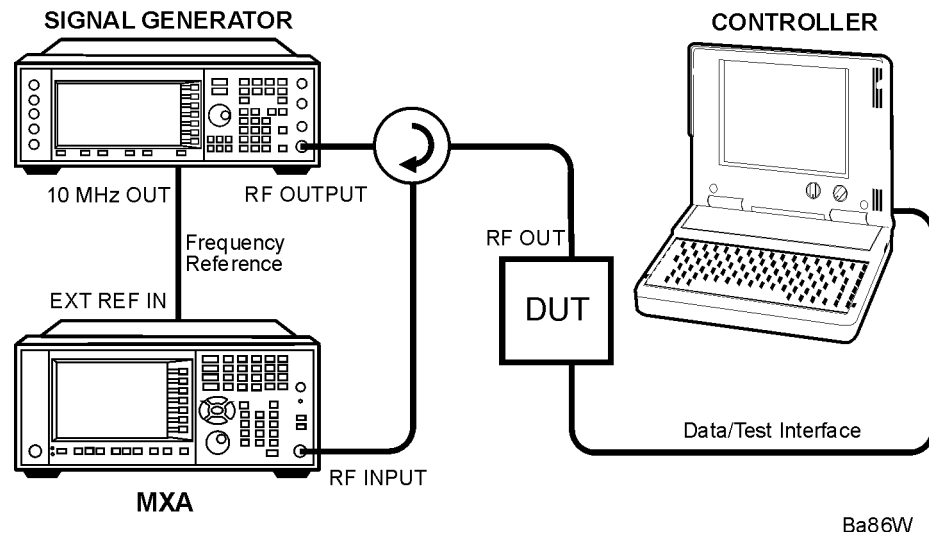

1. Using the appropriate cables, adapters, and circulator, connect the output signal from the DUT to the RF input port of the analyzer.
2. Connect the base transceiver station simulator or signal generator to the DUT through the circulator to initiate a link constructed with the sync and pilot channels, if required.
3. Connect a BNC cable between the 10 MHz OUT port of the signal generator and the EXT REF IN port of the analyzer.
4. Connect the system controller to the DUT through the data/test interface cable to control the DUT operation.

Setting the DUT (Example)

This example uses a signal generated using Agilent N7615B Signal Studio for 802.16 WiMAX. The specific signal used is the Downlink (TDD) example documented in the N7615B Signal Studio for 802.16 WiMAX Help Tutorial, having 1 DL PUSC Zone with 2 bursts.

Frequency: 2.5 GHz

Output Power: -15 dBm (at analyzer input)

Spurious Emissions Measurement

Measurement Procedure

- Step 1.** Press **Mode**, **802.16 OFDMA (WiMAX/Wibro)** to enable the OFDMA measurements.
- Step 2.** Press **Mode Preset** to preset the Mode. Only do this to return the measurement settings to a known state for all measurements in the OFDMA mode.
- Step 3.** If your DUT is a MS, or your signal of interest is an uplink (UL), press the **Mode Setup**, **Radio Device**, **MS** keys to enable OFDMA MS measurements. The default is **BS**.
- Step 4.** Press **FREQ Channel**, **2.5**, **GHz** to set the center frequency to 2.5 GHz.
- Step 5.** Press **Input/Output**, **RF Input**, **RF Coupling** to toggle the RF Coupling to **DC**.
- Step 6.** Press **Meas**, **Spurious Emission** to initiate the Spurious Emissions measurement. Press **More**, **Meas Preset** to preset the measurement. This will return the measurement settings to a known state for only this measurement.

Depending on the current settings, the instrument will begin making the spur measurement. The resulting data is shown on the display or available for export.

A successful Spurious Emissions measurement result should look like [Figure 3-12](#). The spectrum window and the text window show the spurs that are within the current value of the Marker Peak Excursion setting of the absolute limit. Any spur that has failed the absolute limit will have an 'F' beside it.

Figure 3-12

Spurious Emissions Measurement - Default Result

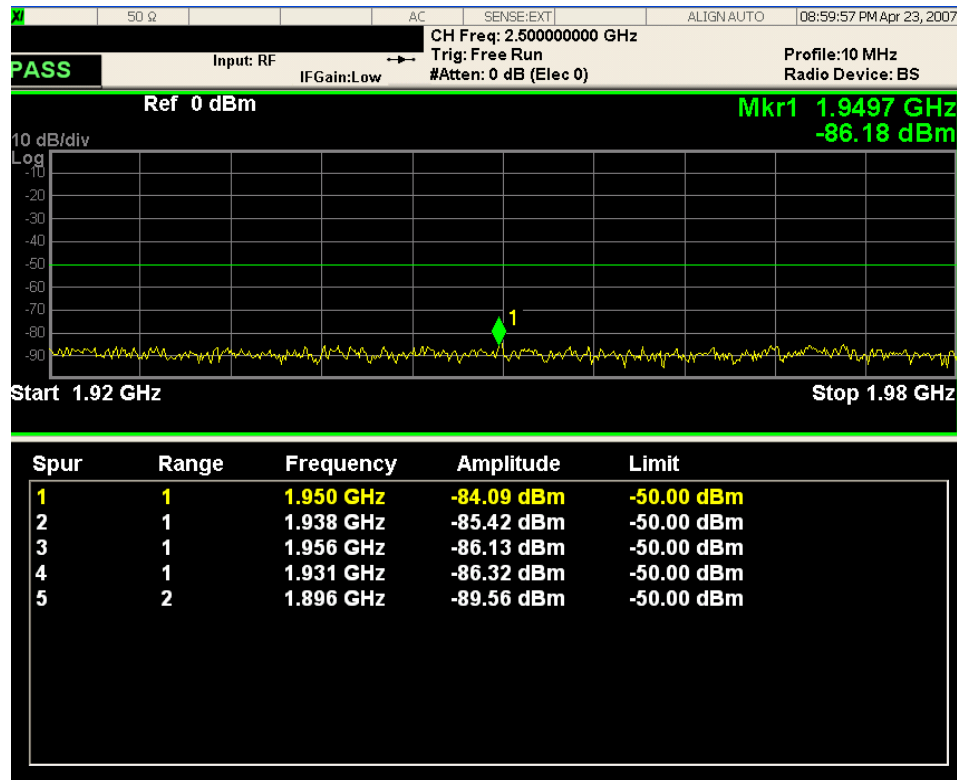

Step 7. The Spur measurement begins using the Examine measurement type, displaying only Range 1 results. A marker is shown at the peak result. To view other ranges press **Meas Setup, Range Table, Range**, and enter the number of the Range to display, then press **Enter**. The Range Table View also allows you to access the menus allowing you to set the range parameters for the Spurious Emissions measurement.

Spurious Emissions Measurement

The first Range Table menu should look like [Figure 3-13](#). The parameters you can set include turning individual Ranges On and Off, Start and Stop frequencies, Res and Video BW, and Filter Type. The text window below the Spectrum display and the keys both show the parameter settings available in this menu.

Figure 3-13 Spurious Emissions Measurement - Range Table View 1

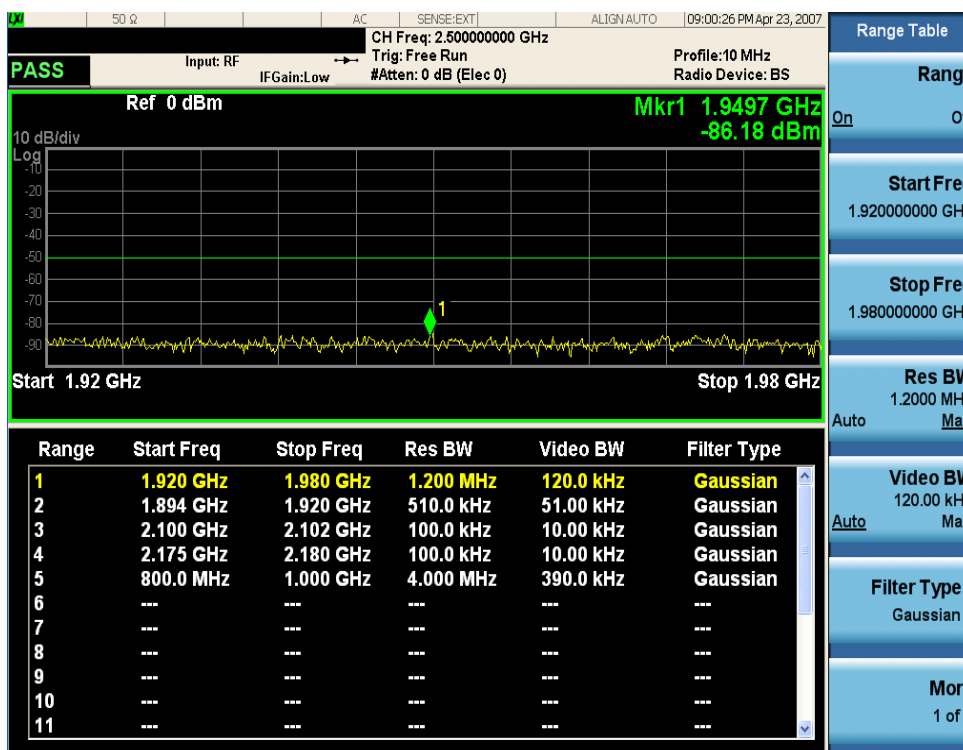

Step 8. Press **More, 1 of 3** to access more menus allowing you to set the range parameters for the Spurious Emissions measurement.

The second Range Table menu should look like [Figure 3-14](#). The parameters you can set include Abs Start and Stop Limits, Peak Excursion and Peak Threshold. The text window below the Spectrum display and the keys both show the parameter settings available in this menu.

Figure 3-14

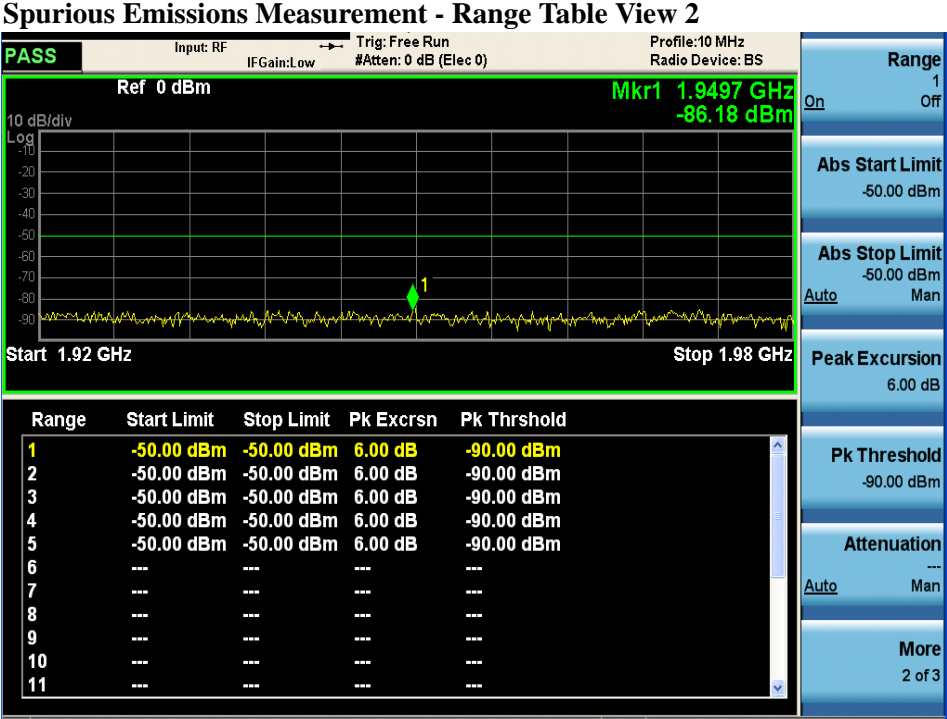

Step 9. Press More, 2 of 3 to access more menus allowing you to set the range parameters for the Spurious Emissions measurement.

The third Range Table menu should look like Figure 3-15. The parameters you can set include Range On/Off by number, settings for Detectors 1 and 2, and Sweep Time and number of Points in the sweep. The Spectrum display and the keys both show the parameter settings available in this menu.

Spurious Emissions Measurement

Figure 3-15

Spurious Emissions Measurement - Range Table View 3

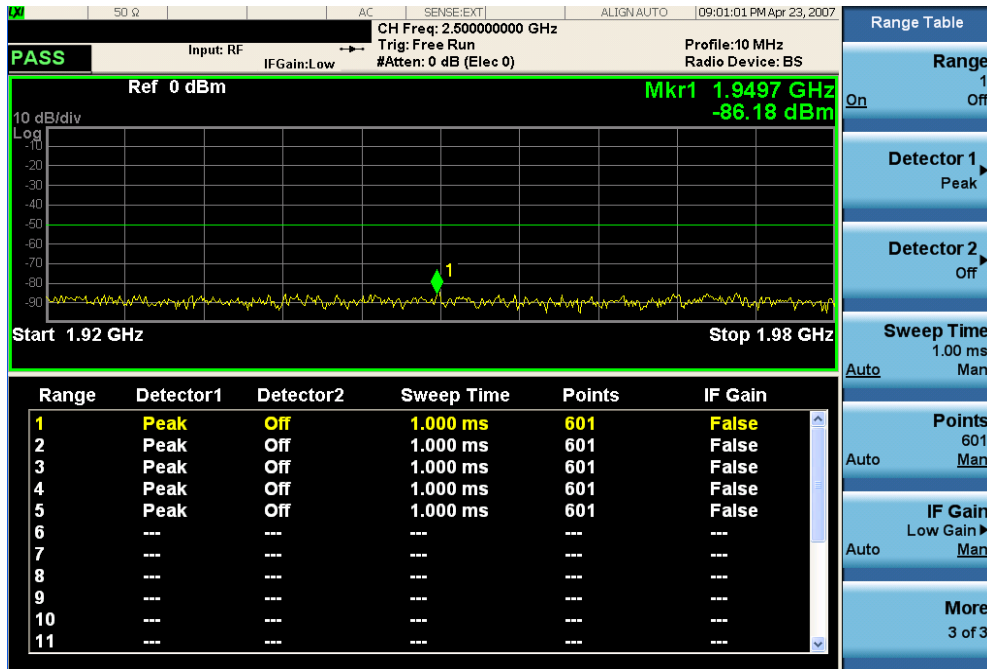

Step 10. Press **IF Gain** to optimize the measurement for your signal level. If you have a very high or low level signal, selecting **Low Gain** or **High Gain** can improve your accuracy. The default is **Auto**.

Step 11. Press **Meas, Setup, Meas Type, Full** to view the entire range of frequencies set for all Ranges in the spurious emission measurement.

If you have a problem, and get an error message, see the “*Error Messages Guide*”.

Occupied Bandwidth Measurements

This chapter explains how to make Occupied Bandwidth measurements on 802.16 OFDMA Base Stations (BS) or Mobile Stations (MS). The instrument measures power across the band, and then calculates its 99.0% power bandwidth.

NOTE Because OFDMA is bursty, you must use the Gate function to obtain valid results when measuring 802.16 OFDMA signals. See the measurement procedure for details.

The DUT under test must be set to transmit the RF power remotely through the system controller. This transmitting signal is connected to the RF input port of the instrument. Connect the equipment as shown.

Figure 3-16 Occupied Bandwidth Measurement System

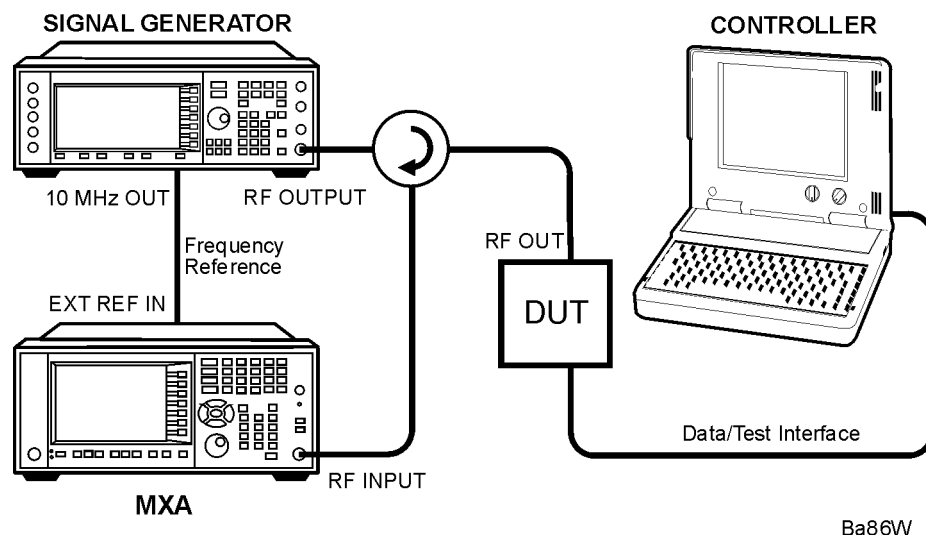

1. Using the appropriate cables, adapters, and circulator, connect the output signal from the DUT to the RF input port of the analyzer.
2. Connect the base transceiver station simulator or signal generator to the DUT through the circulator to initiate a link, if required.
3. Connect a BNC cable between the 10 MHz OUT port of the signal generator and the EXT REF IN port of the analyzer.
4. Connect the system controller to the DUT through the data/test interface cable to control the DUT operation.
5. If used, connect the external Gate trigger signal to a rear-panel connector like External 1 or 2.

Setting the DUT (Example)

This example uses a signal generated using Agilent N7615B Signal Studio for 802.16 WiMAX. The specific signal used is the Downlink (TDD) example documented in the N7615B Signal Studio for

Occupied Bandwidth Measurements

802.16 WiMAX Help Tutorial, having 1 DL PUSC Zone with 2 bursts.

Frequency: 2.5 GHz

Output Power: -15 dBm (at analyzer input)

Measurement Procedure

- Step 1.** Press **Mode, 802.16 OFDMA (WiMAX/Wibro)** to enable the OFDMA measurements.
- Step 2.** Press **Mode Preset** to preset the Mode. Only do this to return the measurement settings to a known state for all measurements in the OFDMA mode.
- Step 3.** If your DUT is a MS, or your signal of interest is an uplink (UL), press the **Mode Setup, Radio Device, MS** keys to enable OFDMA MS measurements. The default is **BS**.
- Step 4.** Press **FREQ Channel, 2.5, GHz** to set the center frequency to 2.5 GHz.
- Step 5.** Press **Meas, Occupied BW** to initiate the occupied bandwidth measurement.
- Step 6.** Press **Meas Setup, Meas Preset** to preset the measurement. This will return the measurement settings to a known state for only this measurement.

NOTE

The next several steps will set the Gate function to make a Channel Power measurement in the data burst of the OFDMA frame.

Gate settings made in any measurement persist for all measurements in the mode.

- Step 7.** Press **Sweep/Control, Gate, Gate View** and toggle it to **On**.
- Step 8.** Press **Gate View Sweep Time** and set it to 1 ms.
- Step 9.** Press **Gate Delay** and set it to 110 us. This sets Gate Start to begin after the Preamble.

TIP

For best results, always set **Gate Delay** to position Gate Start after Max Fast to allow the LO to “settle”.

- Step 10.** Press **Gate Length** and set it to 110 us, about the length of an OFDMA symbol.
- Step 11.** (Optional) Select your **Gate Source** trigger signal, if used. Instead of an external signal, this measurement example uses the default gate source, the **Periodic Timer (Frame)**, which is set to a period of 5 ms, and synchronizes with the RF burst. If you want to use another gate source, like an external trigger signal, you can select the correct input, like **External 1**, under the **Sweep/Control, Gate, More (1 of 2), Gate Source** menu. You will need to adjust the signal parameters under the same menu.
- Step 12.** Press **Gate** and toggle it to **On**.

The Occupied BW measurement result should look like the [Figure 3-17](#).

Figure 3-17

Occupied Bandwidth Measurement - Gate View Result

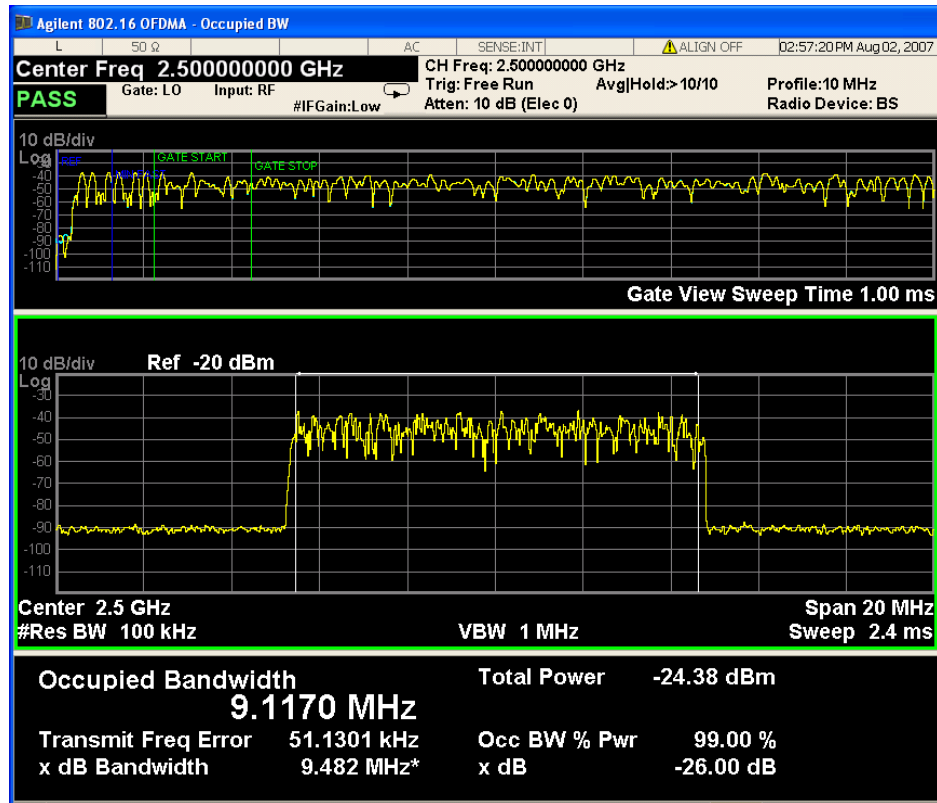

Step 13. Press **Meas Setup, IF Gain** to optimize the measurement for your signal level. If you have a very high or low level signal, selecting **Low Gain** or **High Gain** can improve your accuracy. The default is **Auto**.

Step 14. Press **Meas Setup, Occ BW % Pwr** to change the value of the BW % to another value to suit your test. The default is **99%**.

If you have a problem, and get an error message, see the “*Error Messages Guide*”.

For more information on Time Gating see “[Time Gating Concepts](#)” on page 120.

Troubleshooting Hints

Any distortion such as harmonics or intermodulation, for example, produces undesirable power outside the specified bandwidth.

Shoulders on either side of the spectrum shape indicate spectral regrowth and intermodulation. Rounding or sloping of the top shape can indicate filter shape problems.

Occupied Bandwidth Measurements

Power vs. Time Measurements

This section explains how to make Power vs. Time (PvT) measurements of 802.16 OFDMA Base Stations (BS) or Mobile Stations (MS). Measurement and display of the modulation envelope in the time domain shows the separate rise and fall times of the various bursts in an 802.16 OFDMA signal.

Configuring the Measurement System

The Base Station (DUT) under test has to be set to transmit the RF power remotely through the system controller. This transmitting signal is connected to the instrument's RF input port. Connect the equipment as shown. An interfering or adjacent signal may be supplied as shown.

Figure 3-18 Waveform Measurement System

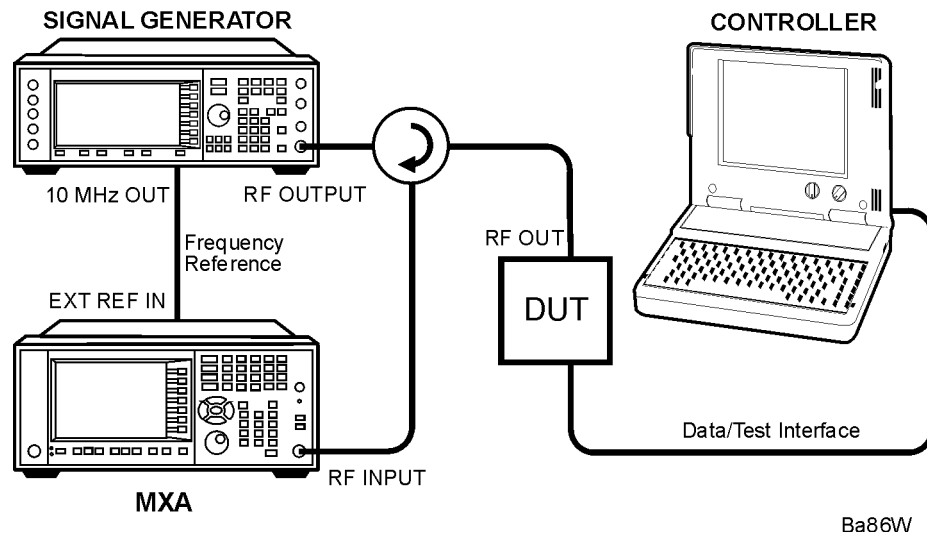

1. Using the appropriate cables, adapters, and circulator, connect the output signal of the DUT to the RF input of the instrument.
2. Connect the base transmission station simulator or signal generator to the DUT through a circulator to initiate a link constructed with sync and pilot channels, if required.
3. Connect a BNC cable between the 10 MHz OUT port of the signal generator and the EXT REF IN port of the instrument.
4. Connect the system controller to the DUT through the data/test interface cable to control the DUT operation.
5. Connect an external trigger, if needed. Press **Mode Setup**, **Trigger** to access a menu to set up inputs and levels for all triggers. You must then select the appropriate trigger under the **Meas Setup**, **Trigger** menu to direct the measurement to use your trigger settings.

Setting the DUT (Example)

This example uses a signal generated using Agilent N7615B Signal Studio for 802.16 WiMAX. The

Power vs. Time Measurements

specific signal used is the Downlink (TDD) example documented in the N7615B Signal Studio for 802.16 WiMAX Help Tutorial, having 1 DL PUSC Zone with 2 bursts.

Frequency: 2.5 GHz

Output Power: -15 dBm (at analyzer input)

Measurement Procedure

- Step 1.** Press **Mode, 802.16 OFDMA (WiMAX/Wibro)** to enable the OFDMA measurements.
- Step 2.** Press **Mode Preset** to preset the Mode. Only do this to return the measurement settings to a known state for all measurements in the OFDMA mode.
- Step 3.** If your DUT is a MS, or your signal of interest is an uplink (UL), press the **Mode Setup, Radio Device, MS** keys to enable OFDMA MS measurements. The default is BS.
- Step 4.** Press **FREQ Channel, 2.5, GHz** to set the center frequency to 2.5 GHz.
- Step 5.** Press the **SPAN** key, enter a numerical span using the front-panel keypad, and press the **MHz** key to set the measurement span in MHz.
- Step 6.** Press **Meas, Pwr vs Time** to initiate the Power vs. Time measurement.
- Step 7.** Press **Meas Preset** to preset the measurement. This will return the measurement settings to a known state for only this measurement.
- Step 8.** The Power vs. Time measurement result should look like [Figure 3-19](#).

Figure 3-19

Power vs. Time Measurement Result - RF Envelope View

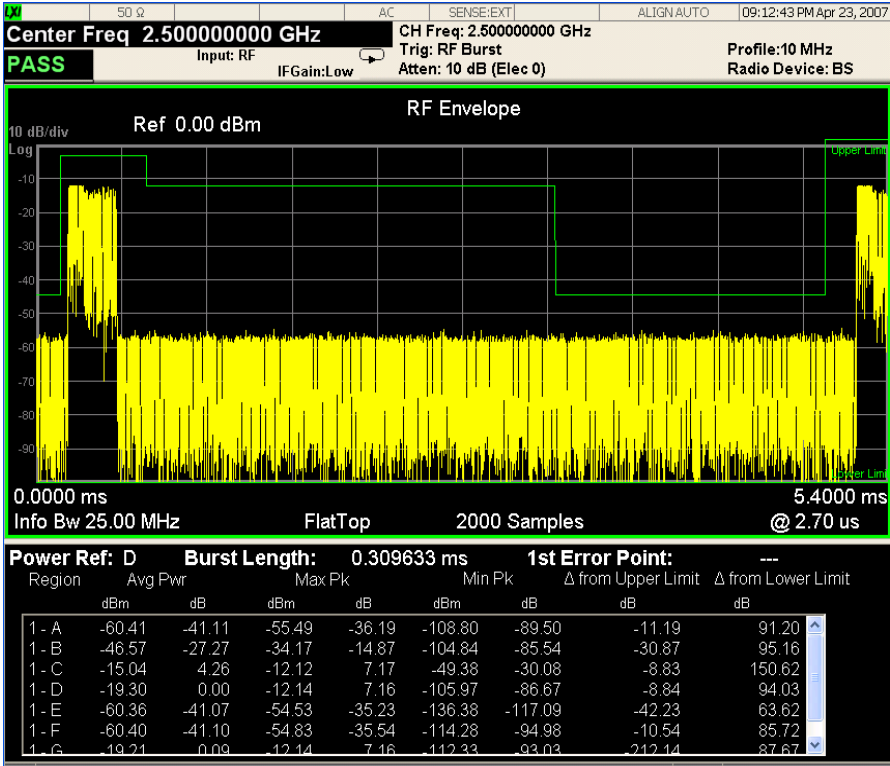

- Step 9.** The graph window shows the time domain view and the text window shows the power values across all regions. If the number of regions are greater than the display area under the spectrum display, you can move the slider with a PC mouse to see the entire table. If you don't have a PC mouse, you can press the "next window" key to move the focus to the data summary area, then press the "zoom" key to expand the table view.
- Step 10.** Because OFDMA is a bursted signal, to stabilize the measurement you may have to use triggering. Press **Trigger** then choose a trigger mode, like **RF Burst (Wideband)**. In the trigger mode you can also set the delay, peak level and positive or negative edge slope trigger. For more information on trigger settings see the Trigger section.
- Step 11.** Press the **AMPLITUDE Y Scale**, and down arrow keys until the waveforms are shown at a convenient voltage scale for viewing.
- Step 12.** Press the **SPAN X Scale**, and down arrow keys until the waveforms are shown at a convenient time scale for viewing.
- Step 13.** Press the **Marker** key to activate a marker. Rotate the knob until the marker is shown at a desired time in the waveform for viewing the trace values at the time position of the marker.
- Step 14.** Press the **Meas Setup** keys to check the keys available to change the measurement parameters from the default condition. You can change the **Capture Length** as well as adjust **Regions/Limits** as necessary.

Power vs. Time Measurements

Modulation Analysis Measurements

This section explains how to make Modulation Analysis measurements on 802.16 OFDMA Base Stations (BS) or Mobile Stations (MS). Modulation analysis provides all the parameters necessary to determine the quality of modulation of an 802.16 OFDMA signal.

Configuring the Measurement System

The DUT under test must be set to transmit the RF power remotely through the system controller. This transmitting signal is connected to the RF input port of the analyzer. Connect the equipment as shown.

Figure 3-20 Channel Power Measurement System

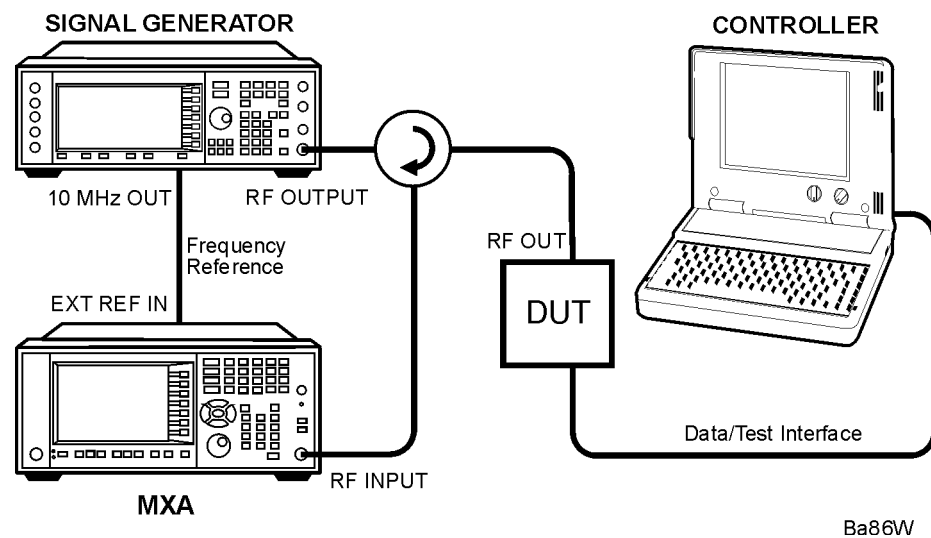

1. Using the appropriate cables, adapters, and circulator, connect the output signal from the DUT to the RF input port of the analyzer.
2. Connect the base transceiver station simulator or signal generator to the DUT through the circulator to initiate a link, if required.
3. Connect a BNC cable between the 10 MHz OUT port of the signal generator and the EXT REF IN port of the analyzer.
4. Connect the system controller to the DUT through the data/test interface cable to control the DUT operation.

Setting the DUT (Example)

This example uses a signal generated using Agilent N7615B Signal Studio for 802.16 WiMAX, and generated using an Agilent MXG. The specific signal used is a Downlink (TDD) having 1 DL PUSC Zone with 8 bursts, each having a different modulation type. This allows the greatest range of the measurement to be shown.

Frequency: 2.5 GHz

Modulation Analysis Measurements

Output Power: –15 dBm (at Signal Generator output)

Measurement Procedure

- Step 1.** Press **Mode, 802.16 OFDMA (WiMAX/Wibro)** to enable the OFDMA measurements.
- Step 2.** Press **Mode Preset** to preset the Mode. Only do this to return the measurement settings to a known state for all measurements in the OFDMA mode.
- Step 3.** If your DUT is a MS, or your signal of interest is an uplink (UL), press the **Mode Setup, Radio Device, MS** keys to enable OFDMA MS measurements. The default is **BS**.
- Step 4.** Press the **Meas, More, Modulation Analysis** keys to enable the Modulation Analysis measurement.
- Step 5.** Press **FREQ Channel, 2.5, GHz** to set the center frequency to 2.5 GHz.
- Step 6.** Press **Meas Setup, Meas Preset** to preset the measurement. This will return the measurement settings to a known state for only this measurement.
- Step 7.** If the OFDMA signal you wish to analyze has more than 1 burst, you must **Recall** a Zone Map to set up the Modulation Analysis measurement. This can be a Zone Map you have saved from an earlier measurement, or you can make a new **Custom Zone Map** by importing a Signal Studio OFDMA setup file. To make a new Zone Map:

NOTE To reduce measurement time, select a trigger setting other than **Free Run**. Selecting **External** or **Periodic Timer** will reduce the burst search time to a 5 ms period instead of a 10 ms period, which is the case when **Free Run** is selected.

1. Use Agilent Signal Studio to create a new **Custom Zone Map**. You can download the Agilent N7615B OFDMA Signal Studio program here: <http://www.agilent.com/find/signalstudio> and select N7615A.
2. Install the N7615B Signal Studio for 802.16 WiMAX program and create the OFDMA signal. You can use Signal Studio to view the Zone Map.
3. Save the Signal Studio setup file using “Save As” with a .SCP extension (Settings file) to a convenient directory.
4. Copy the .SCP setup file to the analyzer. You can use LAN or the USB port. The suggested location for Zone Map files is:
D:\Desktop\My Documents\WiMAXOFDMA.
5. Press **Recall, Data, Open** and the instrument will open a Windows Explorer window. Browse to the WiMAXOFDMA directory and select the .SCP file you copied there.
6. If the .SCP file is valid, the measurement should restart using the imported settings.

Step 8. If you have recalled a Zone Map or Signal Studio setup file, you need to make sure that Mode-level settings agree with those of the recalled signal.

1. Press **Preset Profile** and select the BW used for your signal.
2. Make sure that the settings for **FFT Size**, **BW Ratio**, **Guard Interval**, **Frame Duration** and **Downlink Ratio** agree with your signal:

NOTE When measuring multi-channel signals, select Multi Channel Filter (On) to isolate the measurement channel. The measurement time may be slightly increased, but measurement results are improved.

3.

Press **Mode Setup**, **Radio Std**, and select either **802.16e-2005** or **WiBro**. Using the keys provided, set the values for **FFT Size**, **BW Ratio**, **Guard Interval**, **Frame Duration** and **Downlink Ratio**. These settings will be in effect for all measurements in the mode.

Step 9. The Modulation Analysis default measurement result should look like [Figure 3-21](#). For the OFDMA example signal, the Polar Vector view graph shows the ideal constellation states for all the modulation types contained in the signal, including BPSK, QPSK, QAM16 and QAM64. The data summary on the left side shows RCE (EVM) and Pilot RCE results, and various error measurement results.

Figure 3-21

Modulation Analysis Measurement Result - IQ Measured Polar Constln (Default) View

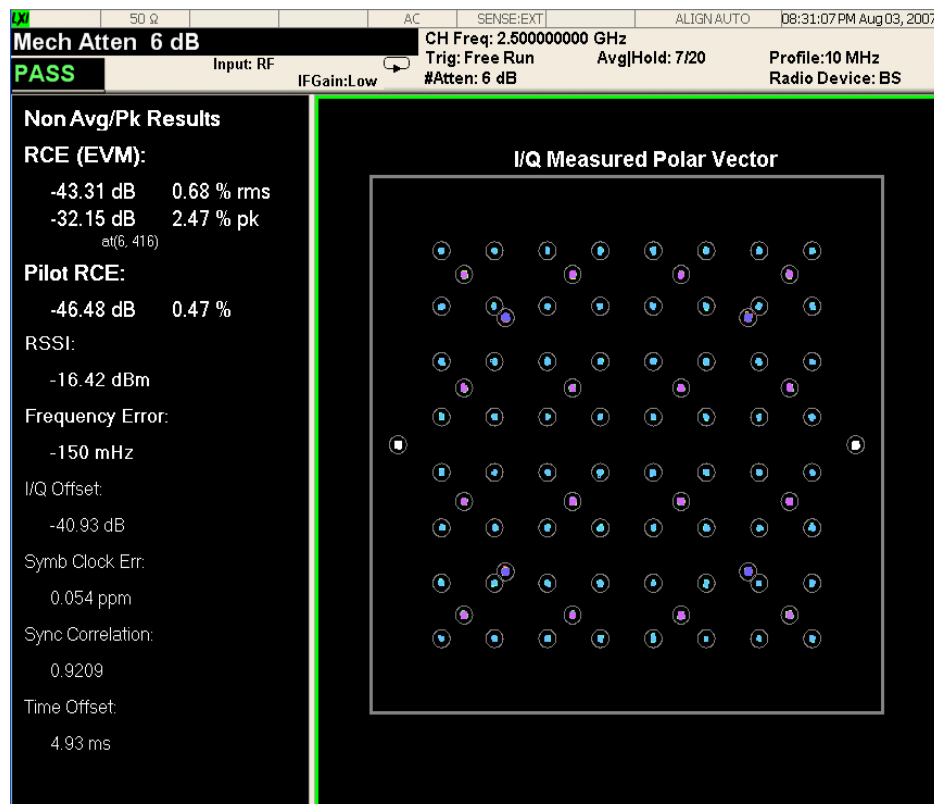

The ideal constellation states are shown as circles, while the measured state traces are colored to correspond to modulation type. See [Table 3-3 on page 65](#). BPSK traces (the 2 states on the outer right

Modulation Analysis Measurements

and left edges of the constellation) are colored white, QPSK states are colored purple, QAM16 states are green, and QAM64 are blue

Table 3-3 IQ Measured Polar Constln State Trace Colors

| Modulation Type | Trace Color |
|-----------------|-------------|
| BPSK | White |
| QPSK | Purple |
| QAM16 | Green |
| QAM64 | Blue |

Step 10. Press **View/Display, Zone & Data Burst Info** to display a tri-pane view of the Zone Burst graph window, the Zone List summary, and the Burst List summary result window as in Figure 3-22. This is the information that was recalled in the Zone Map, or Signal Studio setup file, displayed with the measured results for EVM (in %) and RCE (in dB) by burst.

Figure 3-22 Modulation Accuracy Measurement Result - Zone & Data Burst Info View

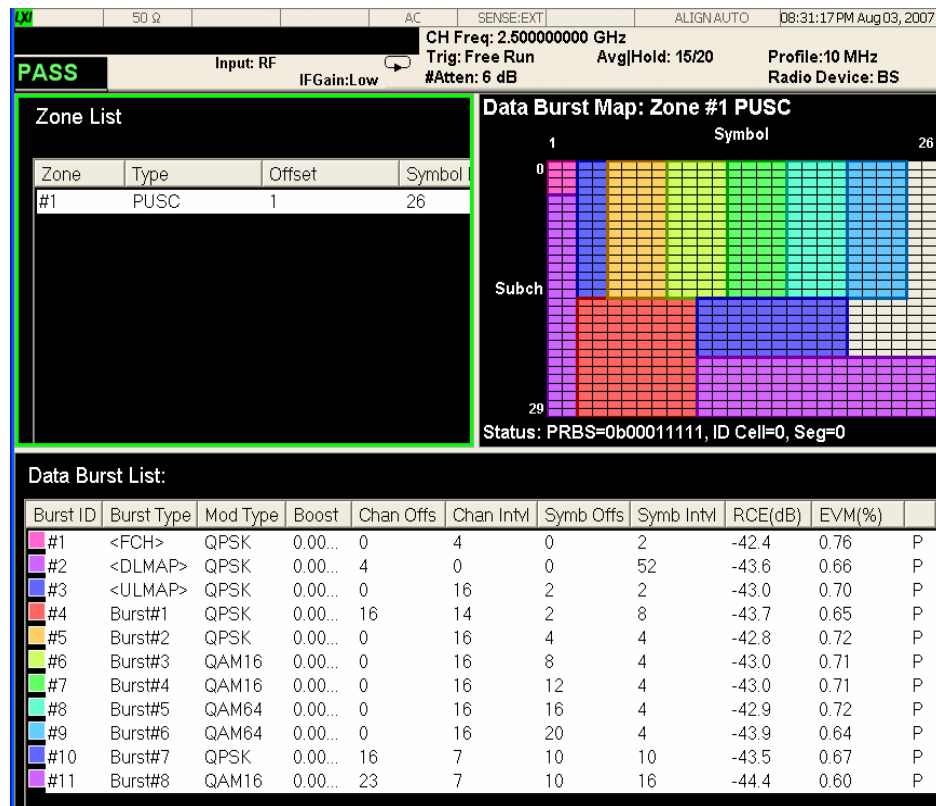

The Zone map is displayed using color codes to indicate the different bursts. The burst numbers are assigned in order of ascending Logical Subchannel number, beginning at the top-left of the zone (subchannel number 1 at the top, and larger numbers on the Y-axis below). The numbering continues

Modulation Analysis Measurements

first filling down, then to the right. The Bursts are color-coded to indicate Burst Number as follows:

Table 3-4 **Zone Map Burst Color Codes**

| Burst ID | Burst Type | Color Code |
|----------|------------|-------------|
| 1 | <FCH> | Cyan |
| 2 | <DL MAC> | Violet |
| 3 | <UL MAC> | Blue |
| 4 | Burst 1 | Aqua |
| 5 | Burst 2 | Orange |
| 6 | Burst 3 | Red |
| 7 | Burst 4 | Purple |
| 8 | Burst 5 | Dark Blue |
| 9 | Burst 6 | Light Green |
| 10 | Burst 7 | Dark Green |
| 11 | Burst 8 | Light Blue |

Step 11. Press **View/Display, Symbol Error (Quad View)** to display a 4-pane view of the Symbol Error vs. Subcarrier (top left), the Symbol Error vs. Symbol (top right), the I/Q Measured Polar Vector graph window (bottom left) and the Data Burst Map graph window. See [Figure 3-23](#).

Figure 3-23

Modulation Accuracy Measurement Result - Symbol Error (Quad View)

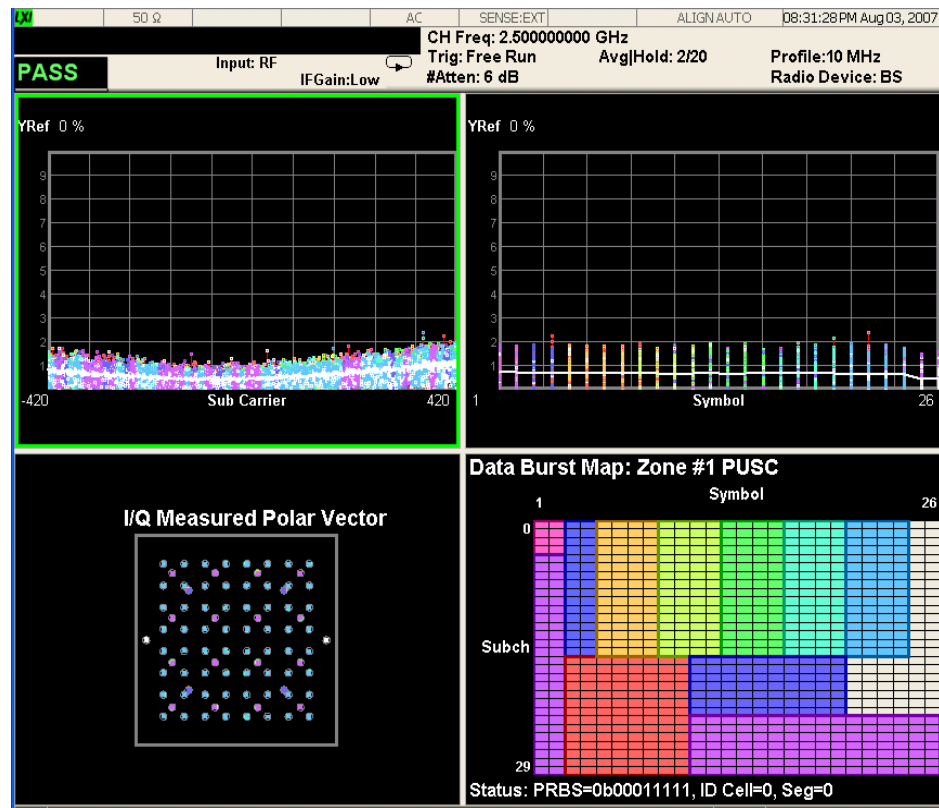

The color codes assigned for the Burst Map are also used in the other windows to see the correlation between the bursts, subcarriers, and symbols.

- Step 12.** Press **View/Display, Symbol Power (Quad View)** to display a 4-pane view of the Symbol Power vs. Subcarrier (top left), the Symbol Power vs. Symbol (top right), the I/Q Measured Polar Vector graph window (bottom left) and the Data Burst Map graph window. See [Figure 3-24](#).

The color codes assigned for the Burst Map are also used in the other windows to see the correlation between the bursts, subcarriers, and symbols.

Modulation Analysis Measurements

Figure 3-24

Modulation Analysis Measurement Result - Symbol Power (Quad View)

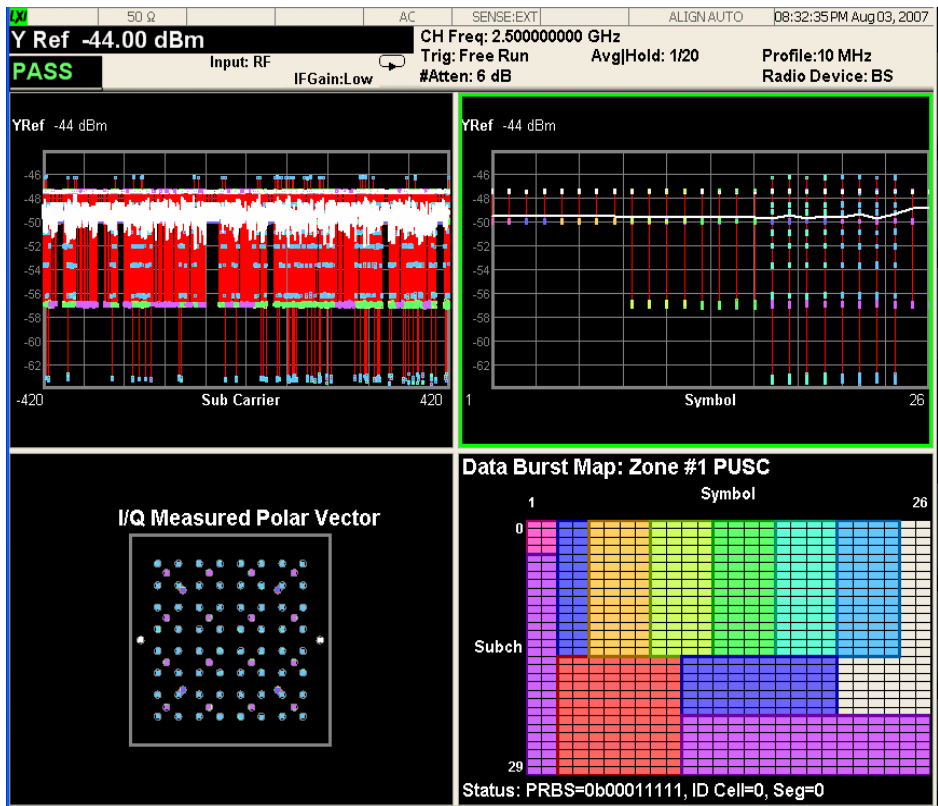

Step 13. Press **View/Display, Peak/Avg Metrics** to display the Modulation Analysis summary result window. See [Figure 3-25](#).

Figure 3-25

Modulation Analysis Measurement - Peak/Avg Metrics View



Step 14. Press View/Display, Spectral Flatness to display a combination view of the Absolute Flatness and Differential Flatness windows. In the data summary below the graphs, the Abs. Max, Abs. Min, Differential Max and Min values are shown. See Figure 3-26.

Modulation Analysis Measurements

In this example the Differential Flatness result has failed due to an over-limit condition at subcarrier -122, visible as the spike above the limit line, to left (negative) of 0 at the center of the lower graph.

Figure 3-26

Modulation Analysis Measurement Result - Spectral Flatness View

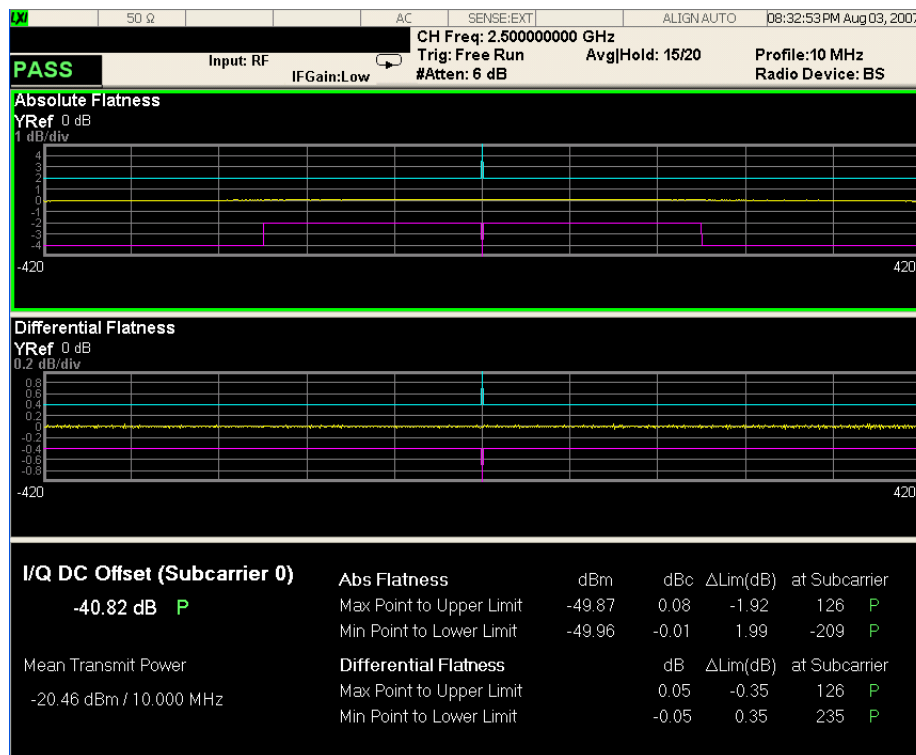

Step 15. Press **View/Display, Power vs. Time & Spectrum** to display a combination view of the Power vs. Time and Spectrum graph windows. The upper window is a time-domain graph of the entire Zone data, which supports the use of markers. The vertical red lines indicate the start and stop time of the bursts defined in the Zone Map. While the green border indicates the focus is on this display the Span X Scale key can be used to view individual bursts in the Zone. See [Figure 3-27](#).

The lower window is a frequency domain display of the entire signal bandwidth as set under the Mode Setup preset. While the green border indicates the focus is on this display the Span X Scale key can be used to view individual subcarriers in the Zone.

Figure 3-27 Modulation Analysis Measurement Result - Power vs. Time and Spectrum View

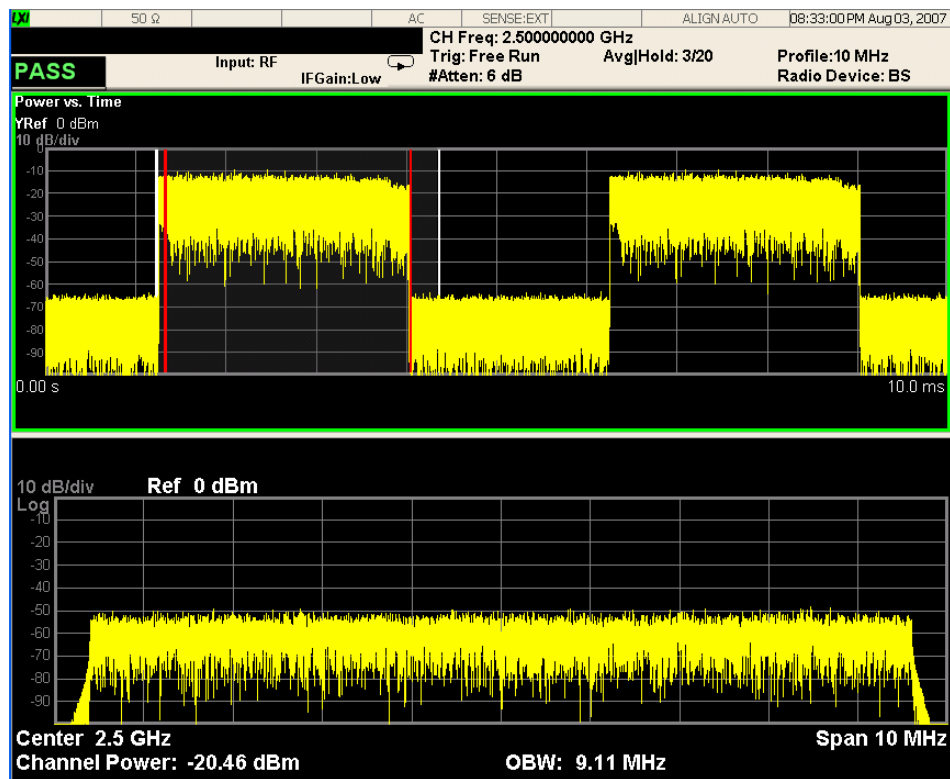

Step 16. Press **Meas Setup**, **More**, **Burst Analysis**, and select **Single Burst**. Using Single Burst analysis you can confine the measurement to a single burst within the Zone Map that is currently active. This is especially helpful for a complicated signal that crowds the displays with many subcarriers and bursts. The following example of Single Burst Analysis uses the same Zone Map as was used for the previous Modulation Analysis examples, but will be set to Burst ID #3, the UL MAC burst. Refer to the [“Modulation Accuracy Measurement Result - Zone & Data Burst Info View”](#) on page 65 for the settings necessary to define a single burst. Subchannel Offset can be thought of as the “start” of the subchannel y-axis map definition, and Subchannel Interval as the length of the subchannel assignments. Symbol Offset can be thought of as the “start” of the Symbol X-axis definition, and the Symbol Interval as the number of Symbols in the burst. In Figure 3-28 below, the modulation scheme for the UL MAC burst is QPSK as shown in the constellation display. The subcarrier error graph shows that the burst occurs across many subcarriers, while the symbol error graph shows the burst consists of only 2 symbols.

Figure 3-28

Modulation Analysis Measurement Result - Single Burst Analysis View

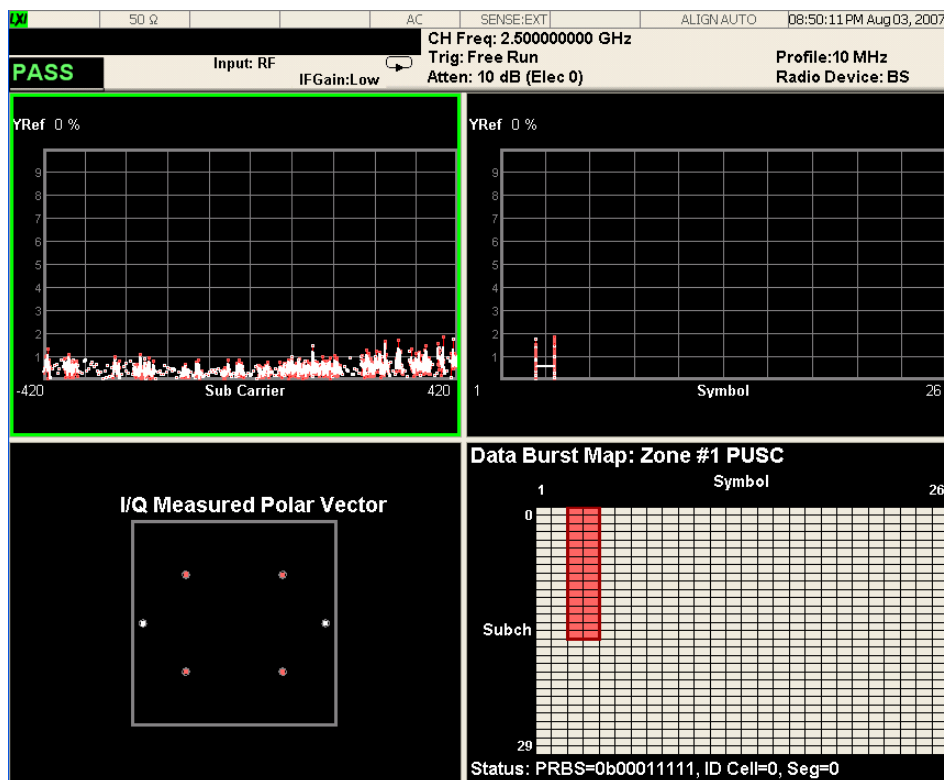

When the measurement is in Single Burst Analysis mode, all the views and adjustments that are available using (whole) Burst Map Analysis mode can be used.

- Step 17.** Press **View/Display, Zone & Data Burst Info** to display a tri-pane view of the Zone Burst graph window, the Zone List summary, and the Burst List summary result window as in [Figure 3-29](#). This is the information that was defined in the **Single Burst** setup menu, displayed with the measured EVM and RCE results by burst.

Figure 3-29 Modulation Accuracy Measurement Result - Zone & Data Burst Info (Single Burst) View

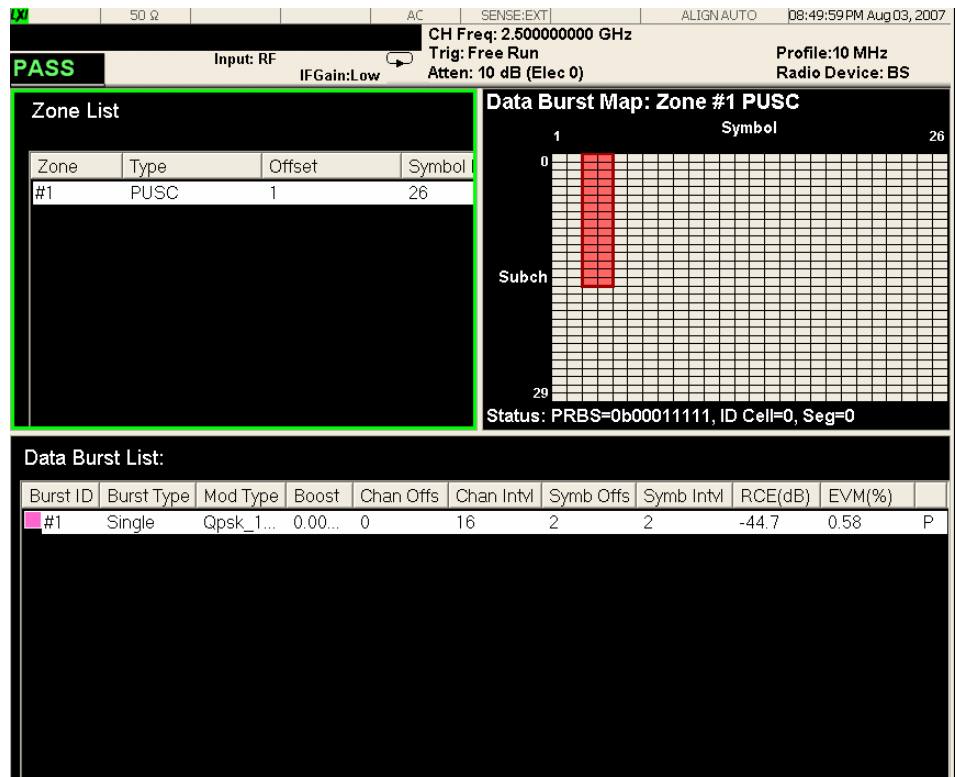

The Zone map is displayed using the same color codes to indicate the selected burst as when other bursts are analyzed.

If you have a problem, and get an error message, see the “*Error Messages Guide*”.

Modulation Analysis Measurements

Power Statistics CCDF Measurements

This section explains how to make Power Statistics Complementary Cumulative Distribution Function (Power Stat CCDF) measurement on an 802.16 OFDMA Base Station (BS). Power Stat CCDF curves characterize the higher level power statistics of a digitally modulated signal.

The Base Station (DUT) under test must be set to transmit the RF power remotely through the system controller. This transmitting signal is connected to the RF input port of the instrument. Connect the equipment as shown.

Figure 3-30 Power Statistics (CCDF) Measurement System

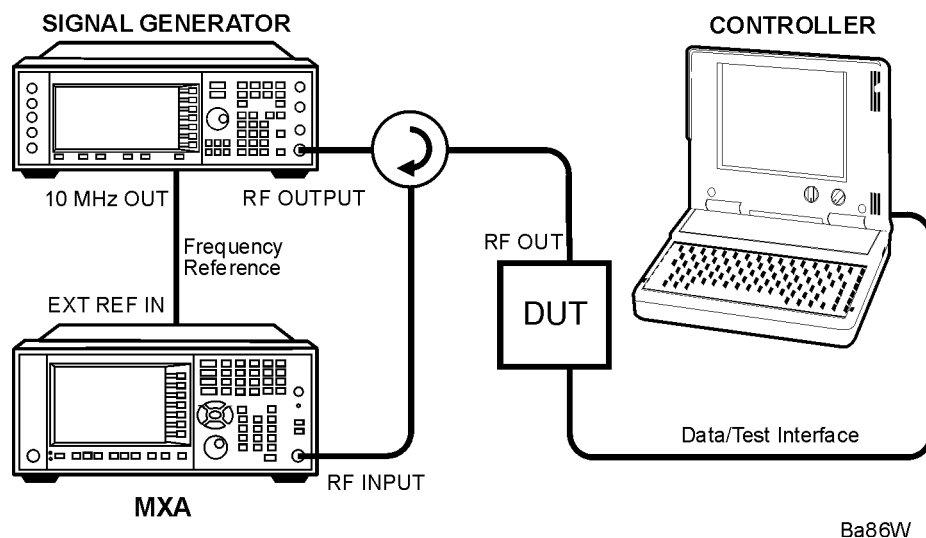

1. Using the appropriate cables, adapters, and circulator, connect the output signal of the DUT to the RF input of the analyzer.
2. Connect the base transceiver station simulator or signal generator to the DUT through the circulator to initiate a link constructed with the sync and pilot channels, if required.
3. Connect a BNC cable between the 10 MHz OUT port of the signal generator and the EXT REF IN port of the analyzer.
4. Connect the system controller to the DUT through the data/test interface cable to control the DUT operation.

Setting the DUT (Example)

This example uses a signal generated using Agilent N7615B OFDMA Signal Studio. The specific signal used is the Downlink (TDD) example documented in the N7615B OFDMA Help Tutorial, having 1 DL PUSC Zone with 2 bursts.

Frequency: 6 GHz

Output Power: -20 dBm (at analyzer input)

Measurement Procedure

- Step 1.** Press **Mode, 802.16 OFDMA (WiMAX/Wibro)** to enable the OFDMA measurements.
- Step 2.** Press **Mode Preset** to preset the Mode. Only do this to return the measurement settings to a known state for all measurements in the OFDMA mode.
- Step 3.** If your DUT is a MS, or your signal of interest is an uplink (UL), press the **Mode Setup, Radio Device, MS** keys to enable OFDMA MS measurements. The default is BS.
- Step 4.** Press **FREQ Channel, 6, GHz** to set the center frequency to 6 GHz.
- Step 5.** Press **Meas, Power Stat CCDF** to initiate the power statistics CCDF measurement.
- Step 6.** Press **Meas Setup, Meas Preset** to preset the measurement. This will return the measurement settings to a known state for only this measurement.

The CCDF measurement result should look like [Figure 3-31](#).

Figure 3-31 Power Statistics CCDF Result

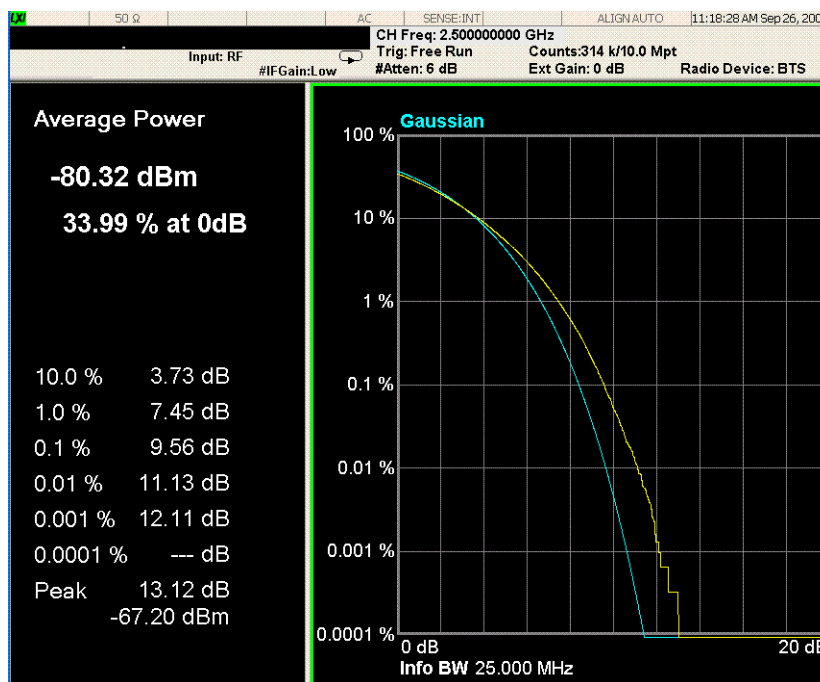

- Step 7.** Press **Span X Scale, Attenuation** to add input attenuation if the power level of your signal of interest is very high.
- Step 8.** Press **Meas Setup, IF Gain** to optimize the measurement for your signal level. If you have a very high or low level signal, selecting **Low Gain** or **High Gain** can improve your accuracy. The default is **Auto**.

If you have a problem, and get an error message, see the “*Error Messages Guide*”.

Troubleshooting Hints

The power statistics CCDF measurement can contribute in setting the signal power specifications for design criteria for systems, amplifiers, and other components. For example, it can help determine the optimum operating point to adjust each code timing for appropriate peak or average power ratio, or both, throughout the wide channel bandwidth of the transmitter for an OFDMA system.

Monitor Spectrum Measurements

This chapter explains how to make Monitor Spectrum measurements on 802.16 OFDMA Base Stations (BS) or Mobile Stations (MS). Monitor Spectrum measurements show a spectrum domain display of the 802.16 OFDMA signal.

NOTE Because OFDMA is bursted, you must use the Gate function to obtain valid results when measuring 802.16 OFDMA signals. See the measurement procedure for details.

This example shows a DUT under test set up to transmit RF power, and controlled remotely by a system controller. The transmitting signal is connected to the RF input port of the instrument. Connect the equipment as shown.

Figure 3-32 Spectrum Measurement System

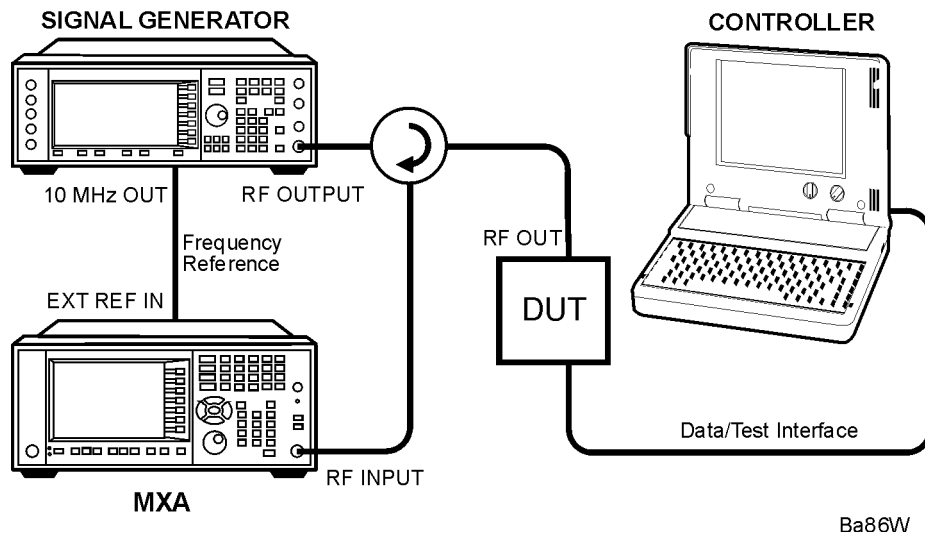

1. Using the appropriate cables, adapters, and circulator, connect the output signal from the DUT to the RF input port of the analyzer.
2. Connect the base transceiver station simulator or signal generator to the DUT through the circulator to initiate a link, if required.
3. Connect a BNC cable between the 10 MHz OUT port of the signal generator and the EXT REF IN port of the analyzer.
4. Connect the system controller to the DUT through the data/test interface cable to control the DUT operation.
5. If used, connect the external Gate trigger signal to a rear-panel connector like External 1 or 2.

Setting the DUT (Example)

This example uses a signal generated using Agilent N7615B OFDMA Signal Studio. The specific signal

Monitor Spectrum Measurements

used is the Downlink (TDD) example documented in the N7615B OFDMB Help Tutorial, having 1 DL PUSC Zone with 2 bursts.

Frequency: 2.5 GHz

Output Power: -26 dBm (at analyzer input)

Measurement Procedure

- Step 1.** Press **Mode, 802.16 OFDMA (WiMAX/Wibro)** to enable the OFDMA measurements.
- Step 2.** Press **Mode Preset** to preset the Mode. Only do this to return the measurement settings to a known state for all measurements in the OFDMA mode.
- Step 3.** If your DUT is a MS, or your signal of interest is an uplink (UL), press the **Mode Setup, Radio Device, MS** keys to enable OFDMA MS measurements. The default is BS.
- Step 4.** Press **FREQ Channel, 2.5, GHz** to set the center frequency to 2.5 GHz.
- Step 5.** Press **Meas, Monitor Spectrum** to initiate the Monitor Spectrum measurement.
- Step 6.** Press **Meas Setup, Meas Preset** to preset the measurement. This will return the measurement settings to a known state for only this measurement.

NOTE The next several steps will set the Gate function to make a Monitor Spectrum measurement in the data burst of the OFDMA frame.

Gate settings made in any measurement persist for all measurements in the mode.

- Step 7.** Press **Gate View** and toggle it to **On**.
- Step 8.** Press **Gate View Sweep Time** and set it to 1 ms.
- Step 9.** Press **Gate Delay** and set it to 110 us. This sets Gate Start to begin after the Preamble.

TIP For best results, always set **Gate Delay** to position Gate Start after Max Fast to allow the LO to “settle”.

- Step 10.** Press **Gate Length** and set it to 110 us, about the length of an OFDMA symbol.
- Step 11.** (Optional) Select your **Gate Source** trigger signal, if used. Instead of an external signal, this measurement example uses the default gate source, the **Periodic Timer (Frame)**, which is set to a period of 5 ms, and synchronizes with the RF burst. If you want to use another gate source, like an external trigger signal, you can select the correct input, like **External 1**, under the **Sweep/Control, Gate, More (1 of 2), Gate Source** menu. You will need to adjust the signal parameters under the same menu.
- Step 12.** Press **Gate** and toggle it to **On**.

The Monitor Spectrum measurement result should look like [Figure 3-33](#).

Figure 3-33 Monitor Spectrum Measurement - Gate View



Step 13. (Optional) To adjust the measurement span frequency press **SPAN X Scale**, enter a numerical span using the front-panel keypad, and select a units key, such as **MHz**.

Step 14. (Optional) To move the “focus” to another pane in the view, press the “**Next Window**” key, below the display.

Step 15. (Optional) Press the **Meas Setup** key to adjust **Avg Number**.

If you have a problem, and get an error message, see the “*Error Messages Guide*”.

For more information on Time Gating see “[Time Gating Concepts](#)” on page 120.

Monitor Spectrum Measurements

Waveform (Time Domain) Measurements

This section explains how to make waveform (time domain) measurements of 802.16 OFDMA Base Stations (BS) or Mobile Stations (MS). Measurement of I and Q modulated waveforms in the time domain disclose the voltages which comprise the complex modulated waveform of a digital signal.

Configuring the Measurement System

The DUT under test must be set to transmit the RF power remotely through the system controller. This transmitting signal is connected to the RF input port of the analyzer. Connect the equipment as shown.

Figure 3-34 Channel Power Measurement System

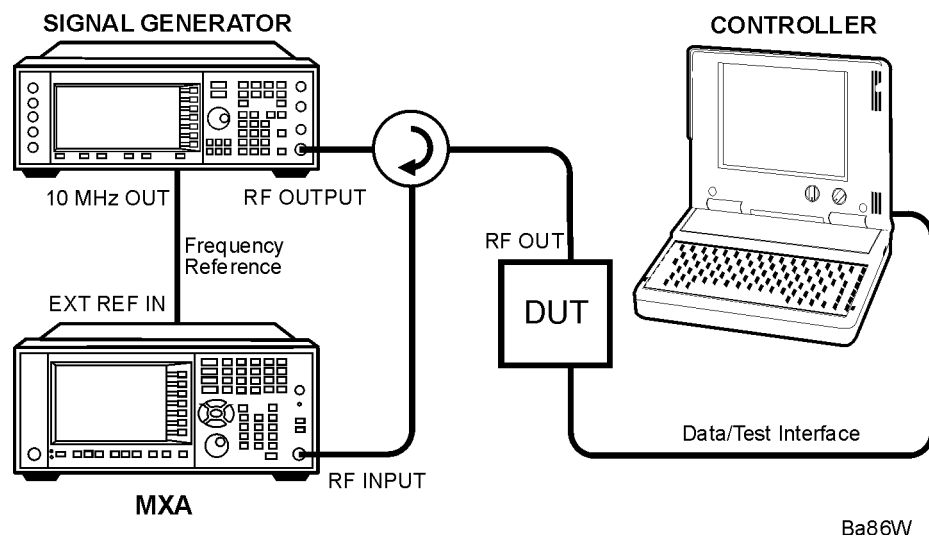

1. Using the appropriate cables, adapters, and circulator, connect the output signal from the DUT to the RF input port of the analyzer.
2. Connect the base transceiver station simulator or signal generator to the DUT through the circulator to initiate a link, if required.
3. Connect a BNC cable between the 10 MHz OUT port of the signal generator and the EXT REF IN port of the analyzer.
4. Connect the system controller to the DUT through the data/test interface cable to control the DUT operation.

Setting the DUT (Example)

This example uses a signal generated using Agilent N7615B OFDMA Signal Studio. The specific signal used is the Downlink (TDD) example documented in the N7615B OFDMA Help Tutorial, having 1 DL PUSC Zone with 2 bursts.

Frequency: 2.5 GHz

Output Power: -20 dBm (at analyzer input)

Measurement Procedure

- Step 1.** Press **Mode, 802.16 OFDMA (WiMAX/Wibro)** to enable the OFDMA measurements.
- Step 2.** Press **Mode Preset** to preset the Mode. Only do this to return the measurement settings to a known state for all measurements in the OFDMA mode.
- Step 3.** If your DUT is a MS, or your signal of interest is an uplink (UL), press the **Mode Setup, Radio Device, MS** keys to enable OFDMA MS measurements. The default is **BS**.
- Step 4.** Press **FREQ Channel, 2.5, GHz** to set the center frequency to 2.5 GHz.
- Step 5.** Press **Meas, IQ Waveform** to initiate the Waveform measurement.
- Step 6.** Press **Meas Setup, Meas Preset** to preset the measurement. This will return the measurement settings to a known state for only this measurement.
- Step 7.** Press **Trigger, RF Burst (Wideband)** to set the measurement trigger.
- Step 8.** Press **RF Burst (Wideband)** to access the RF Burst Setup menu.
- Step 9.** Because OFDMA is a bursted signal, to stabilize the measurement you may have to use triggering:

Press **Trigger** then choose a trigger mode, like **RF Burst (Wideband)**.

Press **Trigger Level** to set the measurement trigger level.

In the trigger menu you can also set the delay, peak level and positive or negative edge slope trigger. For more information on trigger settings see the Trigger section.

The Waveform measurement RF Envelope view result should look like [Figure 3-36](#). The graph window shows the filter type and IF BW, and the text window shows the mean and peak-to-mean power values.

Figure 3-35

IQ Waveform Measurement Result - RF Envelope (Default View)

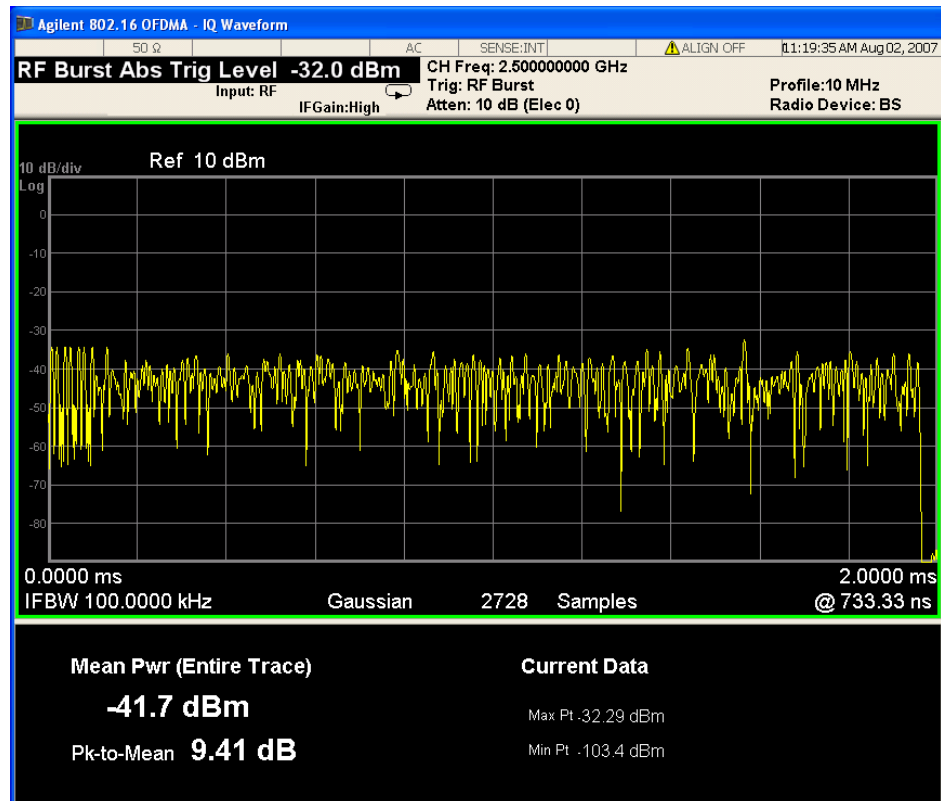

- Step 10.** Press **View/Trace, IQ Waveform** to see the individual I and Q components of the signal.
- Step 11.** Press **SPAN X Scale, Scale/Div, 50 μ s** to display the waveform at a convenient time scale for viewing.
- Step 12.** Press the **AMPLITUDE Y Scale, Scale/Div, 1 mV** to display the waveform at a convenient time scale for viewing.

The IQ Waveform measurement result should look like [Figure 3-35](#).

Waveform (Time Domain) Measurements

Figure 3-36

IQ Waveform Measurement Result - IQ Waveform View

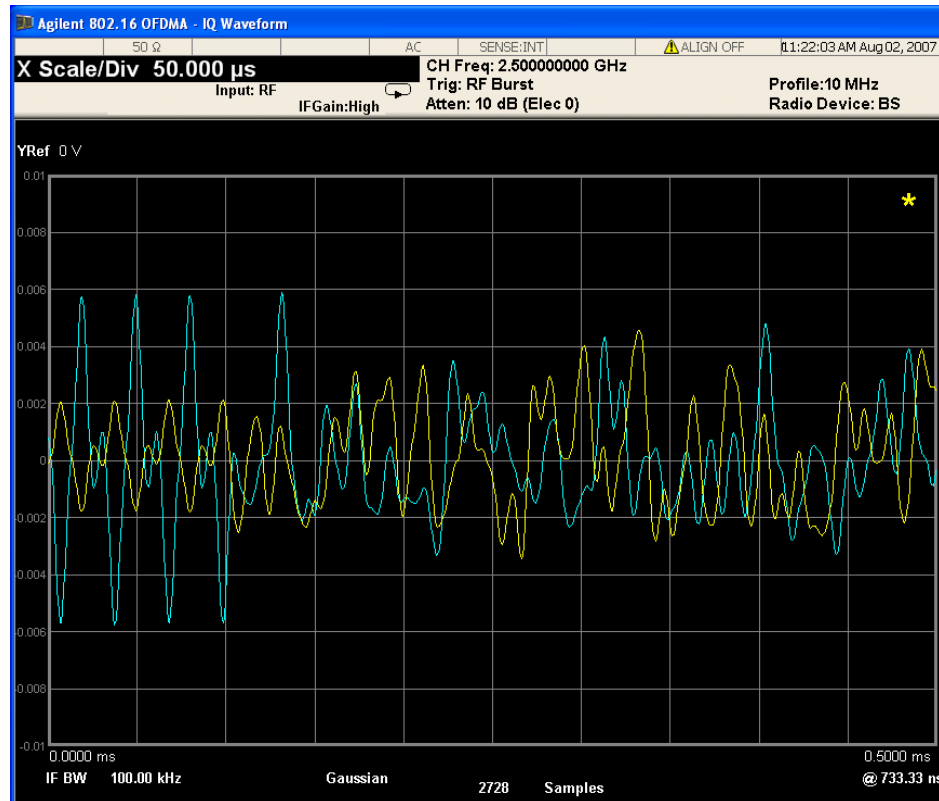

Step 13. Press the **Marker Function** key to display the menu allowing selection of the markers, including Band Power and Noise Power, as shown below:

Figure 3-37

Waveform Measurement Result - Marker Example: Interval Power

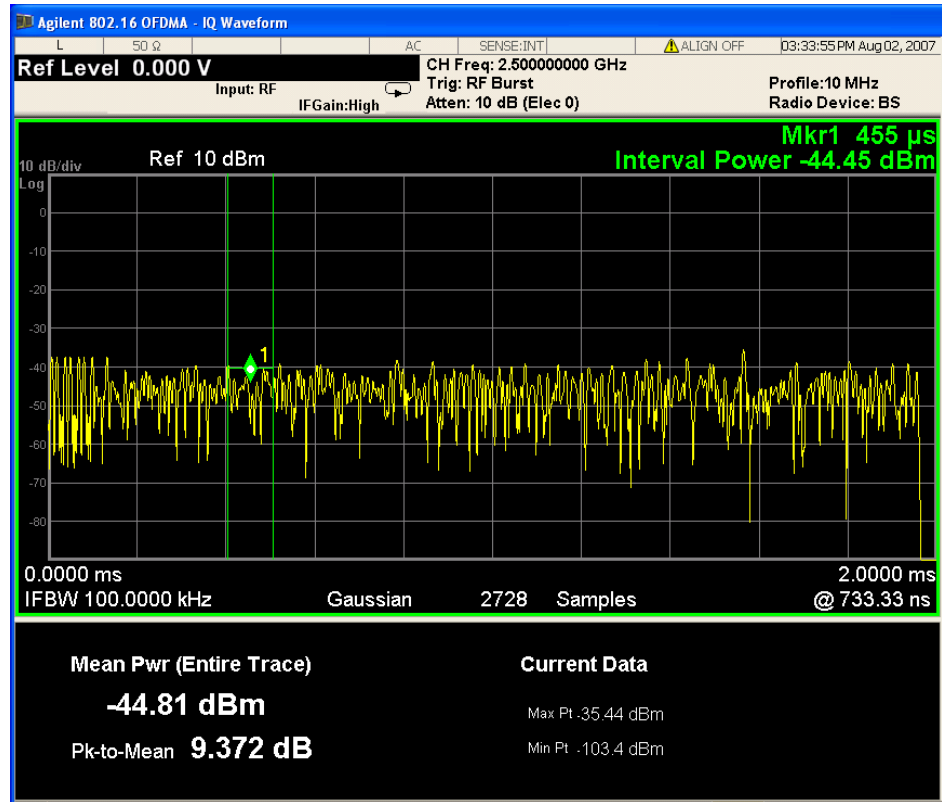

In the example above, the Interval Power marker is selected and the value is displayed above the top reference graticule.

- Step 14.** Press the **Meas Setup** key to check the parameters available to change the selected values for your measurement.

Waveform (Time Domain) Measurements

Baseband I/Q Measurements Available for X-Series Signal Analyzers

The following table shows the measurements that can be made using Baseband I/Q inputs:

Table 4-1 BBIQ Supported Measurements vs. Mode

| Mode | Measurements |
|--------------|--|
| GSM | IQ Waveform GMSK Phase & Freq EDGE EVM |
| 802.16 OFDMA | IQ Waveform Power Stat CCDF Modulation Analysis |
| TD-SCDMA | IQ Waveform Power Stat CCDF Code Domain Mod Accuracy |
| cdma2000 | IQ Waveform Power Stat CCDF Code Domain Mod Accuracy QPSK EVM |
| W-CDMA | IQ Waveform Power Stat CCDF Code Domain Mod Accuracy QPSK EVM |
| 1xEV-DO | IQ Waveform Power Stat CCDF Forward Link Code Domain Reverse Link Code Domain Forward Link Mod Accuracy Reverse Link Mod Accuracy QPSK EVM |
| LTE | IQ Waveform Power Stat CCDF |
| LTE TDD | IQ Waveform Power Stat CCDF |
| DTMB | IQ Waveform Power Stat CCDF Mod Accuracy |

Table 4-1 **BBIQ Supported Measurements vs. Mode**

| Mode | Measurements |
|---------------------|--|
| DVB-T/H | IQ Waveform Power Stat CCDF Mod Accuracy |
| ISDB-T | IQ Waveform Power Stat CCDF Mod Accuracy |
| CMMB | IQ Waveform Power Stat CCDF Mod Accuracy |
| IQ Analyzer (Basic) | IQ Waveform Complex Spectrum |

Baseband I/Q Measurement Overview

The Baseband I/Q functionality is a hardware option, Option BBA. If the option is not installed in the instrument, the I/Q functionality cannot be enabled.

The Baseband I/Q option provides four input ports and one Calibration Output port. The input ports are I, I-bar, Q, and Q-bar. The I and I-bar together compose the I channel and the Q and Q-bar together compose the Q channel. Each channel has two modes of operation:

Single Ended
(unbalanced)

In this mode, only the main port (I or Q) is used and the complementary ports (I-bar or Q-bar) is ignored. The I and Q ports are in single-ended mode when Differential “Off” is selected.

Differential
(balanced)

In this mode, both main and complementary ports are used. To activate this mode, select Differential “On” from the I and Q Setup softkey menus.

The system supports a variety of input passive probes as well as the Agilent 1153A active differential probe using the infinimax probe interface.

NOTE

To avoid duplication, this section describes only the details unique to using the baseband I/Q inputs. For generic measurement details, refer to the previous “Making Measurements” sections.

To make measurements using baseband I/Q Inputs, make the following selections:

- Step 1.** Select a measurement that supports baseband I/Q inputs.
- Step 2.** Select the I/Q Path
Press **Input/Output, I/Q, I/Q Path**. Select from the choices present on the screen. The path selected is shown at the top of the measurement screen.
- Step 3.** Select the appropriate circuit location and probe(s) for measurements. For details see [““Selecting Input Probes for Baseband Measurements” on page 160”](#) in the Concepts chapter.
- Step 4.** Select baseband I/Q input connectors.
- Step 5.** If you have set the I/Q Path to **I+jQ** or to **I Only**, press **I Setup**.
 - A. Select whether **Differential (Balanced)** inputs is **On** or **Off**.
 - B. Select the input impedance, **Input Z**.
 - C. Input a **Skew** value in seconds.
 - D. Set up the I Probe by pressing **I Probe**
 - a. Select probe **Attenuation**

- b. Calibrate the probe. Press **Calibrate...** to start the calibration procedure. Follow the calibration procedure, clicking **Next** at the end of each step.

Step 6. If you have set the I/Q Path to **I+jQ** or to **Q Only**, press **Q Setup**

- a. Select whether **Differential (Balanced)** inputs is **On** or **Off**.
- b. Select the input impedance, **Input Z**.
- c. Input a **Skew** value in seconds.
- d. Set up the I Probe by pressing **I Probe**
 - i. Select probe **Attenuation**
 - ii. Calibrate the probe. Press **Calibrate...** to start the calibration procedure. Follow the calibration procedure, clicking **Next** at the end of each step.

Step 7. Select the reference impedance by pressing **Reference Z**, and inputting a value from one ohm to one megohm. The impedance selected is shown at the top of the measurement screen.

Step 8. If you using cables that were not calibrated in the probe calibration step, press **I/Q Cable Calibrate...** Follow the calibration procedure, clicking **Next** at the end of each step.

Step 9. After completing the baseband IQ setup procedures, make your desired measurement.

During the execution of your measurement you may encounter problems which generate error codes. Referring to the following common errors may be helpful.

If **Err** is shown in the annunciator bar, press the **System, Show, Errors** hard and soft keys to read the detailed error information.

- **Error Code 145 “Under Range”**

If the input signal level is too low to make a valid measurement, this error may appear. If you cannot increase the power into the tester, you need to increase the input sensitivity by adjusting the ADC range.

Press **Meas Setup, More (1 of 3), More (2 of 3), Advanced, ADC Range**, and then **Manual** keys. Increase the setting from None (default) to 6 dB, for example. Another option is to use the **Auto** setting (the **Auto** setting is not used as the default to improve measurement speed).

Press **Restart** to make another measurement and observe the results. Re-adjust the ADC as necessary to obtain a valid measurement.

- **Error Code 217 “Burst Not Found”**

This error indicates the burst signal cannot be detected because of inappropriate parameter settings or an incorrect signal.

For CDMA signals this error means that the tester has failed to find any active channels in the input signal as specified. To improve the correlation some critical parameters need to be adjusted, for example, the input signal level or scramble code.

- **Error Code 219 “Signal too noisy”**

This error means that your input signal is too noisy to capture the correct I/Q components. To make a more stable measurement the trigger source may need to be set to **Frame**, for example.

- **Error Code 413 “ADC Input overload”**

This warning means that your measurement has erroneous results due to the excessive input power level. To correct this condition, the input signal level must be reduced by using the internal and/or external attenuators.

Press the **Mode Setup, Input, Input Atten** keys to enter an attenuation value to reduce the transmitted power from the MS. This allowable range is up to 40 dB.

If you want to attenuate more than 40 dB, connect your external attenuator between the **RF INPUT** port and the DUT. Be sure to add its attenuation value to the readings of the measurement result.

To automate this calculation, press the **Mode Setup, Input, Ext Atten** keys to enter the additional attenuation value. The allowable range is up to 100 dB. The power readings of the measurement take into account the external attenuation value.

For more details consult the chapter in this book dedicated to the measurement in question, or see the “Instrument Messages” manual.

This chapter explains the 802.16 OFDMA communications system including WiMAX and WiBro, and details how various measurements are performed by the instrument. Suggestions for optimizing WiMAX measurements and troubleshooting WiMAX signal problems, as well as a list of reference documents for further investigation, are provided.

WiMAX (Worldwide Interoperability for Microwave Access) refers to a communications system based on the 802.16 standard that provides high-speed data services for point-to-point and point-to-multipoint systems, for mobile and fixed transmission. The focus of the 802.16 OFDMA standard is mobile transmission, which is also the focus of this chapter. WiMAX uses OFDMA (Orthogonal Frequency Division Multiple Access) technology which enables rapid throughput, latency, spectral efficiency, and advanced antennae support. WiMAX is designed to support “last mile” data and cellular communications applications, to provide mobile service in less densely populated outlying metropolitan areas that face cost barriers to installation of wired infrastructure. Among its advantages, WiMAX Mobile supports the following services:

- Provides high-speed mobile data and telecommunications services, offering a wireless alternative to cable for last mile broadband access.
- Enables non-line of- sight (NLOS) operation.
- Uses a scheduling MAC (Media Access Controller) that guarantees a subscriber must compete only once for network access, in contrast to Wi-Fi, which uses a contention MAC, that can impair service to more distant customers and reduces the quality of VoIP and IPTV.
- Provides backhaul for wireless LAN hot-spots or cellular base stations.

802.16 OFDMA Overview

802.16 OFDMA supports both WiMAX and WiBro technologies, which are summarized below. OFDMA (WiMAX Mobile) is an evolution of OFDM (WiMAX Fixed), and its structure is similar to OFDM. This section describes aspects of the WiMAX framing structure that OFDMA and OFDM have in common, then proceeds to explain those aspects of the WiMAX format that are specific to OFDMA. The strong advantage of OFDMA over OFDM is that it enables multiple users simultaneously over time, dramatically improving bandwidth efficiency. Note that both versions of WiMAX use OFDM signals, so signals in this document are referred to as “OFDM” signals.

IEEE 802.16 OFDMA Mobile

IEEE 802.16 OFDMA is a wireless standard that supports fixed and mobile wireless access (BWA) systems for metropolitan area networks. IEEE 802.16 OFDMA is sometimes also referred to as “WirelessMAN_OFDMA”. The IEEE 802.16 standard supports many bandwidths (e.g. 1.25 MHz, 5 MHz, 10 MHz, and 20 MHz) with fixed subcarrier spacing using a scalable architecture. The scalable architecture is based on a scalable subchannelization structure with variable Fast Fourier Transform (FFT) sizes, where the FFT sizes scale with bandwidth to keep subcarrier spacing fixed.

WiBro

WiBro (Wireless Broadband) is a wireless broadband internet technology developed by the Korean telecoms industry. WiBro base stations offer an aggregate data throughput of 30 to 50 Mbit/s and cover a radius of 1-5 km, allowing for the use of portable internet usage within the range of a base station. WiBro technology will also offer Quality of Service (QoS). The inclusion of QoS will allow for WiBro to stream video content and other loss-sensitive data in a reliable manner. These appear to be the stronger advantages that WiBro provides over the WiMAX-OFDMA standard, but the proprietary nature of WiBro and its use of licensed spectrum, that may not be available across the globe, may keep it from adoption as an international standard. While WiBro is exacting in its requirements, from spectrum use to equipment design, WiMAX-OFDMA leaves many of these issues to the equipment provider, while providing enough detail to ensure interoperability between designs

The OFDMA Frame Structure

The OFDMA frame structure shares the following features with the frame structure of OFDM (WiMAX Fixed): use of preambles, an FCH, UL and DL maps, and use of TTG and RTG transition gaps. The critical difference between OFDM and OFDMA lies in its use of subchannels to enable transmission of multiple bursts over the same symbol time period. OFDMA also enables the use of different modulation schemes over the same symbol time.

Figure 6-1 OFDMA Frame Structure (Required Zones for TDD Mode Only Shown)

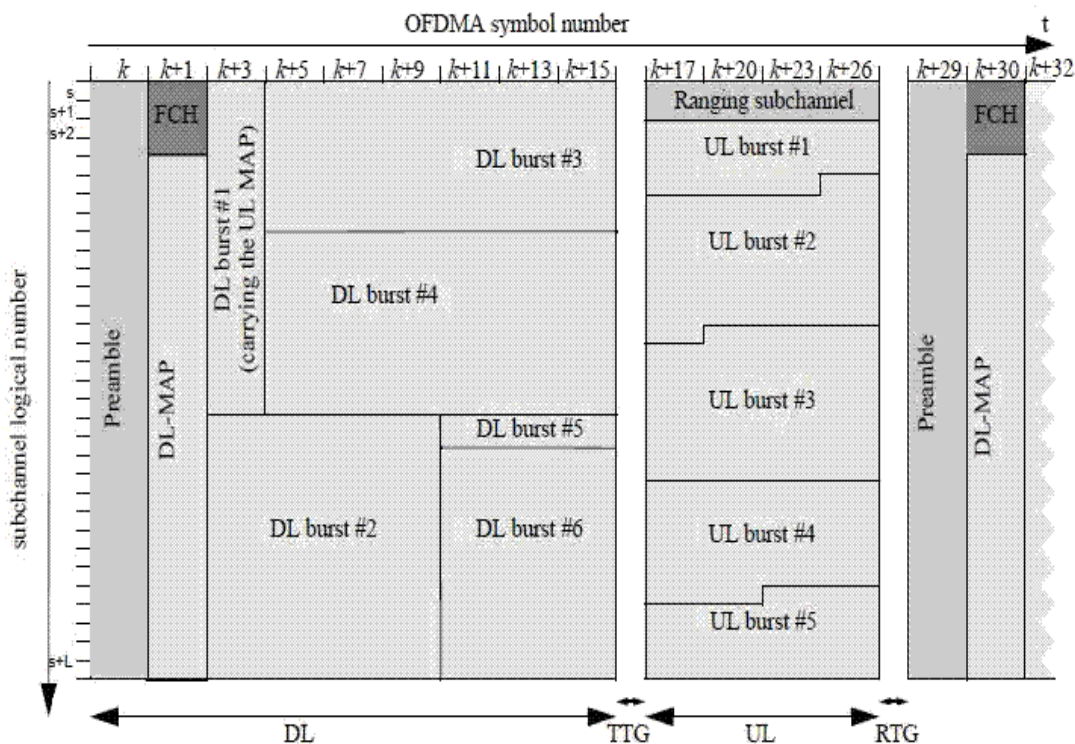

In contrast to the OFDM frame structure, OFDMA uses data bursts that overlap in time, as is shown in [Figure 6-1](#). In addition, each increment in symbol time is defined in terms of “zones” (see “[OFDMA Zones](#)” on page 104), as figure [Figure 6-2](#) illustrates.

Figure 6-2 OFDMA Subframe Division into Zones

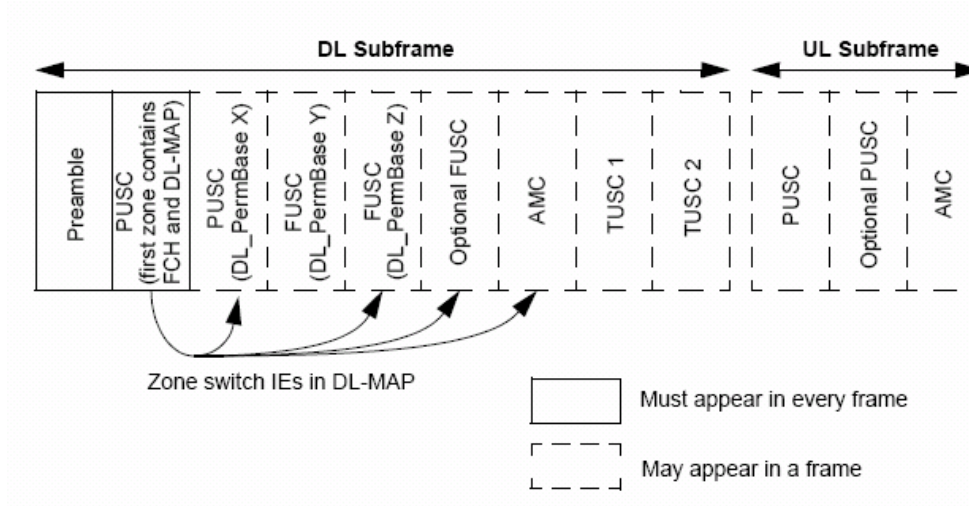

OFDMA Slots

The minimum unit of data in OFDMA is a “slot”. A slot is defined by two parameters, symbol time and subchannel number. Three slot sizes are most commonly used: 1 subchannel by 1 OFDMA symbol, 1 subchannel by 2 OFDMA symbols, and 1 subchannel by 3 OFDMA symbols, as shown in [Table 6-3](#)

Figure 6-3 Commonly Used Slot Arrangements

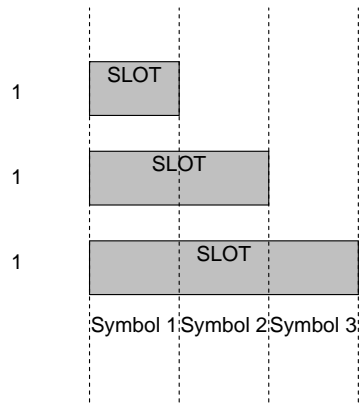

Different permutation zones (“OFDMA Zones” on page 104) use different slot sizes.

OFDMA Subchannels and Bursts

Unlike OFDM (WiMAX Fixed), OFDMA uses multiple, layered subchannels. Carriers are organized into logical subchannels. Each carrier consists in approximately 28 subcarriers. The subchannel-to-subcarrier assignment changes for every symbol, based on a permutation formula affected by variables such as Cell-ID, sector number, and so on. A MAC (Media Access Controller) layer assigns user data to one or more logical subchannels to ensure there is enough symbol time to carry the required number of bits.

The number of subchannels, and the symbol time length, can vary for each burst. Unlike OFDM, this allows for maximum efficiency in the use of bandwidth, both in enabling the overlapping of bursts by users, and in optimally allocating subchannel and symbol time usage.

Figure 6-4 Subchannels and Symbols Composing an OFDMA Burst

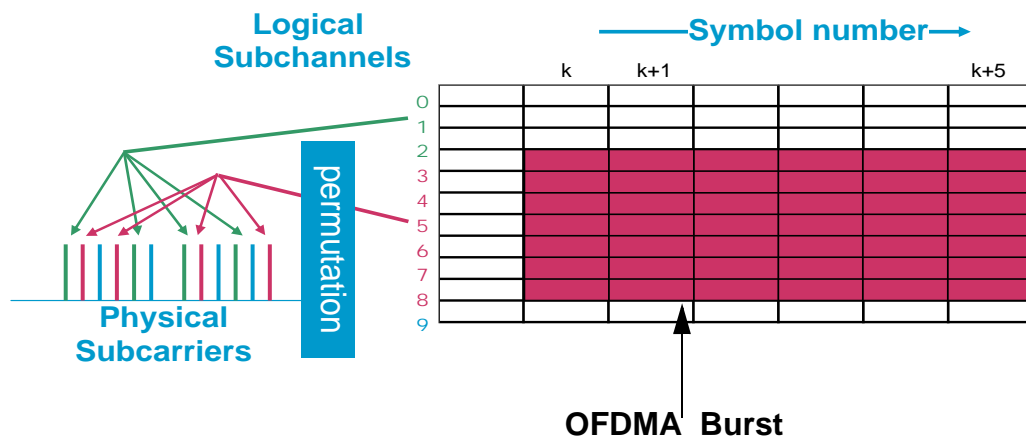

A data burst is a set of contiguous subchannels and symbols, as shown in Figure 6-4. The base station assigns a data burst/region to a user to use to receive or transmit data.

OFDMA Zones

An OFDMA zone, also referred to as a permutation zone, is a contiguous set of symbols that have a consistent subchannel-to-tone mapping. A zone contains all subchannels but occurs over a variable length in symbol time. The parameters for each zone vary so the mapping for each zone is variable, except for the first DL zone, which always consists in a preamble, the FCH, a DL- and UL Map, as well as data bursts. [Figure 6-5 on page 104](#)

Each zone contains independent pilot locations, pilot values, “data burst” definitions, and a subchannel mapping algorithm. Pilot locations are not fixed, but recur in a pattern over multiple symbols. A “data burst” occupies an abstract subchannel vs symbol grid. Note that the abstract mapping means that QPSK, 16QAM, and 64QAM can all be present in the same OFDMA symbol, separable only by use of the correct “permutation equation”.

Among the types of zones that have been defined for use in OFDMA are the following:

- PUSC - Partial Usage of Subcarrier Channels
- FUSC - Full Usage of Subcarrier Channels
- OPUSC - Optional Partial Usage of Subcarrier Channels
- OFUSC - Optional Partial Usage of Subcarrier Channels
- AAS - Adaptive Antenna System
- AMC _ Adaptive Modulation and Coding

Zones are used to help implement basestation functionality, such as beamforming, to assign subchannels to different sectors of a single cell, and to define subchannelization that reduces basestation to basestation interferences.

Figure 6-5 OFDMA Zones

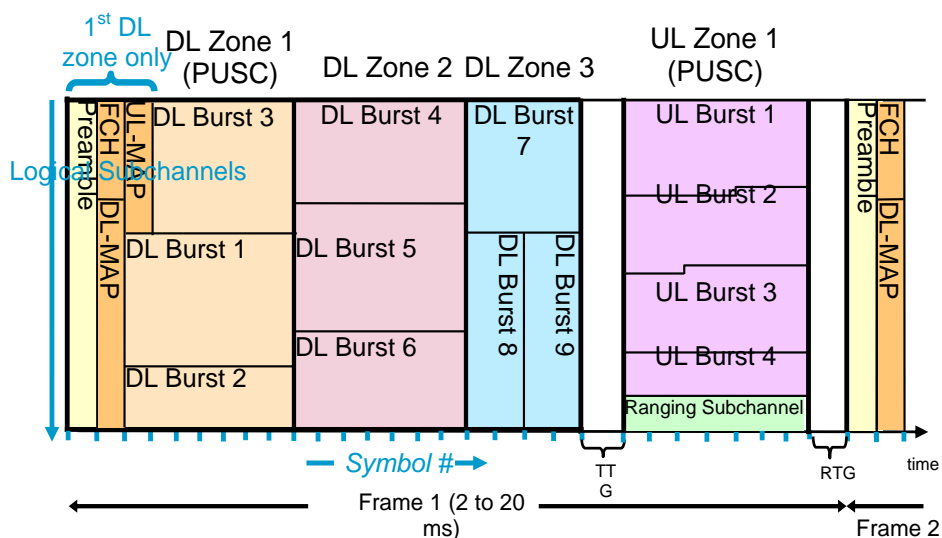

A Summary Comparison of OFDMA and OFDM

The table below contrasts OFDMA and OFDM features, and indicates the far greater complexity of OFDMA.

Table 6-1 A Comparison of OFDMA and OFDM Features

| Features | OFDMA (Mobile WiMAX) | OFDM (Fixed WiMAX) |
|-------------------------|---|---|
| Carriers | OFDMA with 128, 512, 1024, or 2048 (but not 256) carriers, in 1.25, 5, 10, or 20 MHz BWs respectively, and additional BW options for European implementation. | OFDM with 256 carriers, 17 BW options ranging from 1.25 - 20 MHz (with variable sub-carrier spacing). |
| Coding | CC is mandatory, CTC is required for WiBro, and STC and CTC are optional but frequently used. | CC is only mandatory coding scheme, STC is optional. |
| Preambles | Multiple preambles, with 114 preambles available | Long and Short basic preambles |
| Modulation per carrier | Modulation series based on segment and IDCell. | All carriers have same modulation in one symbol |
| New features with OFDMA | Permutation zones: PUSC, FUSC, OPUSC, AMC, OFUSC, TUSC1, TUSC2 | |
| | Bursts and zones allocated by subchannel and symbol | |
| | Subchannel divided into segments (BTS sectors). | |
| | Physical subchannels renumbered to map to logical subchannels | |
| | Hybrid automatic repeat request (HARQ) | |
| | Adaptive antenna system (AAS) for beamforming. | |
| | Power Boosting | |

Measuring the Frequency Spectrum

The analyzer can perform spectrum analysis using either a scalar (also called “stepped FFT measurements”) or a vector measurement. Scalar measurements provide amplitude-only information over the full frequency range of the instrument. Vector measurements provide both phase and amplitude information over the processing bandwidth of the instrument.

Measuring the Wideband Spectrum

Analysis of a WiMAX signal typically starts with a wideband spectrum measurement. A wideband spectrum measurement is used to verify the center frequency, nominal signal bandwidth, amplitude level, and sidelobe level of the WiMAX signal. It is also an opportunity to verify the level of any spurs and other interference signals present in the frequency band that may cause errors during digital demodulation.

Verifying the spectral content is typically performed using a maximum-hold detection scheme. For peak amplitude and spurious measurements of the OFDM signal, the analyzer is configured with a large frequency span (perhaps using the scalar measurement mode) and max-hold averaging. Continuous peak-hold averaging is a measurement function used by the analyzer to measure and display the largest magnitude (determined over many measurements) for each frequency point in the span.

Measurement of low level spurious and interference signals should be performed using a Gaussian window, which provides the highest dynamic range in the measurement. The Gaussian window offers the lowest sidelobe level of any analyzer window at slightly reduced amplitude accuracy. Combining peak hold averaging and Gaussian windowing is ideal to ensure that no significant signals are missed either in the band or out.

Lastly, the analyzer’s input range must be correctly set in order to obtain accurate measurements. If the input range testing is too low (more sensitive than necessary), the analyzer’s analog-to-digital converter (ADC) circuitry is overloaded and introduces distortion into the measurement. If the range is set too high (less sensitive than necessary), there may be a loss of dynamic range due to additional noise. If the wideband spectrum for the WiMAX test signal is acceptable, the instrument can be re-configured for the next analysis step, which is a measurement of the narrowband spectrum.

Measuring the Narrowband Spectrum

For narrowband spectrum analysis of the WiMAX signal, the instrument’s frequency span should be set to approximately 1.1 times the nominal bandwidth of the signal. Alternately the span can be configured to match the bandwidth of a typical WiMAX front-end filter. Using a frequency span close to a typical receiver’s RF bandwidth allows the analyzer measurements to be performed with similar input noise and interference levels as would be seen in practice.

Narrowband measurements also provide improved frequency resolution and greater accuracy in setting the center frequency of the instrument or verifying the center frequency of the signal under test. The improved frequency resolution results from the inverse relationship between span and RBW. Accurate amplitude measurements of the WiMAX signal are required for system verification, troubleshooting and compliance with local regulations.

Amplitude measurements as a function of frequency for these noise-like signals should be performed using RMS (video) averaging and RMS detection. The detection mechanisms in the analyzer are always

RMS. The analyzer calculates the frequency spectrum using a Fast Fourier Transform (FFT) that directly results in the true RMS power of the signal whether it is a single tone, noise, or any complex signal. RMS averaging produces a statistical approximation of the true power level over the measured time record(s), which includes on/off times and the transient effects of the bursted OFDM signal.

Time-variant signals such as WiMAX signals often require spectral analysis over a smaller portion of the entire waveform, for example, during a subframe. In this case, the measurement needs to be stabilized using the trigger control in the analyzer. Triggering the analyzer can easily be accomplished and the details will be provided in the next section. The importance of triggering for a time-variant waveform can be seen in [Figure 6-6 on page 107](#), which shows the difference between the spectrum of a OFDM signal when the instrument is not triggered (upper display) and when it is triggered (lower display). The sidelobe levels for the untriggered response rapidly change from individual measurement to measurement as the spectrum measurement is made on different parts of the time-variant waveform. In comparison, the triggered response maintains the spectral shape as the instrument is triggered at the beginning of each OFDM frame. Both measurements were made with the averaging disabled. Both measurements are accurate, but the change in trigger conditions changes the portion of the signal that is measured.

Figure 6-6 Frequency domain response of a OFDM signal without using an instrument trigger (upper trace) and using a trigger to set the beginning of the downlink frame (lower trace). (Example from the Agilent 89600).

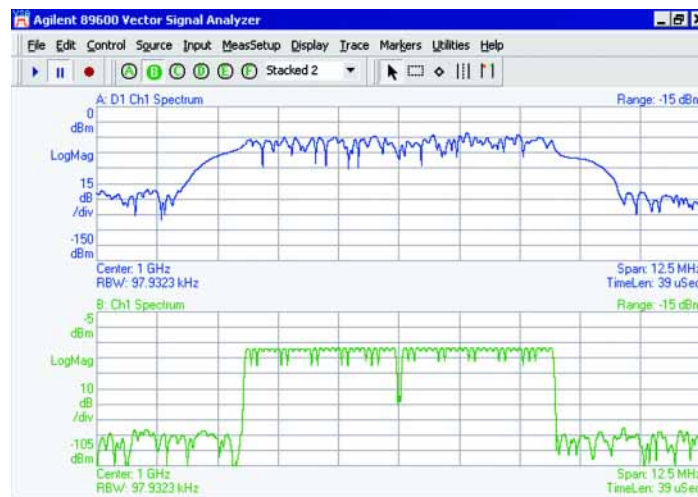

Finding Frames and Triggering Measurements

When first examining the pulsed characteristics of the WiMAX signal, it is often necessary to adjust the time record length in order to see the entire frame or several frames within the waveform display.

A time-domain display using a large number of points and showing one to two frames can be used to measure the subframe lengths and transition gaps. These measurements can also be used to verify the measured OFDM frame duration against the IEEE 802.16-2005 standard.

Triggering the analyzer at specific time intervals within the WiMAX waveform will require setting the trigger type and magnitude level. Once the analyzer is properly triggered, analysis of different parts within the waveform can then be made using the trigger delay function of the instrument.

Figure 6-7 Measurement of RTG time using marker functions. Upper trace shows the frequency of the displayed time domain time record (shown in the lower trace). (Example from the Agilent 89600).

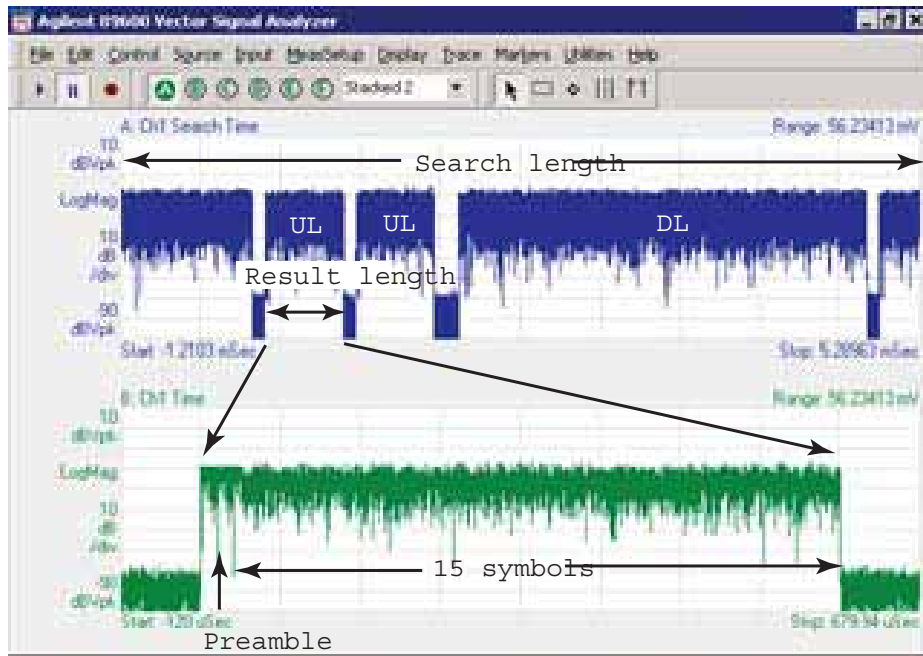

Finding the Trigger Level

The trigger level is typically set (in linear voltage units) to a percentage of the total signal range. One way to determine this level, prior to triggering, is to examine the time domain waveform in a linear power format. This format is available when the Symbol Error vs Symbol or Symbol Error vs Subcarrier view are selected when the **Modulation Analysis** measurement is accessed using the **Meas** menu, and **Lin** is selected in the **AMPTD Y Scale** menu. A level setting that is 10 to 50 percent of the approximate voltage maximum is a good start for bursted signals. This assumes that the voltage is close to zero during the “off” times in the waveform. Note that once the trigger level is determined, changing the format back to Log for subsequent time domain measurements provides the most useful display for examining the RF envelope of this bursted signal. This format is available when the Symbol Error vs Symbol or Symbol

Error vs Subcarrier view are selected, and Log is selected in the Y Scale menu.

Introducing a Trigger Delay

Trigger delay allows detailed measurements of specific parts of the signal. If trigger delay is zero, the analyzer takes data immediately after the trigger conditions are satisfied and then processes the results. If a trigger delay is positive (this is called a “post-trigger delay”) the analyzer waits through the duration of the delay before data is acquired. The post-trigger delay allows the analyzer to begin the measurement at any time into the waveform, for example, at the beginning of the first uplink frame. A trigger delay that is negative, which is called a “pre-trigger delay”, allows measurement of the rising edge of the RF burst including any transient effect that may occur prior to the trigger.

Stabilizing the displayed measurement using the trigger functions allows you to verify and troubleshoot the OFDM signal using time and frequency domain analysis. For example, by measuring signal level changes such as amplitude droop in the time domain or flatness and ripple effects in the frequency domain, you may uncover thermal problems in the amplifiers power stages or improper analog or digital filtering respectively. Unexpected frequency tilt and poor center frequency accuracy may be the result of poor component or synthesizer performance. Turn on and turn-off transients may create demodulation errors in the WiMAX receiver.

These may seem like very basic measurements, but a significant number of system problems can be traced to these behaviors. Such problems may come from analog or digital circuits, or interactions between them. Linking time and frequency measurements with proper triggering can provide a high level of confidence in the signal quality before digital demodulation takes place.

Capturing Signals In Real Time

An analyzer performing vector signal analysis is not a real-time receiver but rather is a block-mode receiver. It captures a time record, and processes and displays the result before capturing the next block of data. Typically the processing and analysis time is longer than the capture time so there may be a gap between the end of one time record and the beginning of the next. Those gaps in time imply that the analyzer is not a real-time processor. This also applies to an analyzer that is configured to trigger on an event such as the change in the amplitude at the beginning of a burst. It may take the analyzer longer to process the current record than the time it takes for the next trigger event to occur.

Here again, the analyzer is not operating in real-time. Fortunately, vector signal analyzers provide a way to get real-time measurements for a limited length of time by using a time capture or recording of the input waveform. Time capturing allows the storage of complete time records with no time gaps produced in the record. The time capture is performed prior to data processing and once the waveform is captured, the signal is played back for analysis.

The signal analyzer captures the time record directly from the measurement hardware and stores the record in memory for immediate analysis or future use. Capturing the time record has the added benefit that the same signal can be analyzed over many different combinations of instrument settings including all the time and frequency measurements discussed in this section. One benefit of starting with a good set of vector measurements is the ability to choose a time capture length that is long enough for complete analysis, but not so long as to cause slow transfer due to excessively large capture files.

Verifying OFDMA signal Impairments

Performing vector measurements can provide verification of the quality of the OFDMA signal, providing the groundwork for proper instrument configuration and successful signal analysis. These measurement techniques can also be used to uncover signal problems that may create difficulties when demodulating a WiMAX or WiBro waveform. In the tables below you will find a summary of some of the measurements and signal impairments that can be analyzed using basic frequency and time domain measurements. The associated analyzer function or instrument configuration is listed in the column to the right.

Table 6-2 **Frequency Domain Analysis**

| | |
|------------------------------|------------------------------|
| Bandwidth | Marker Offset, OBW |
| Center frequency | OBW |
| Sidelobe level | Marker, Peak Hold |
| Spurious | Marker, Peak Hold |
| Amplitude level and flatness | Marker, Band Power, PeakHold |

Table 6-3 **Time Domain Analysis**

| | |
|---------------------------------|---------------------------|
| Frame timing | Marker Offset, Triggering |
| DL subframe timing | Marker Offset, Triggering |
| UL subframe timing | Marker Offset, Triggering |
| TTG timing | Marker Offset, Triggering |
| RTG timing | Marker Offset, Triggering |
| Symbol timing | Marker Offset, Triggering |
| Symbol power | Band Power, Triggering |
| Pulse droop | Marker Offset, Triggering |
| Turn-on and turn-off transients | Marker Offset, Triggering |

Demodulating and Troubleshooting the Subframe

Configuring the Signal Analyzer for Demodulating a WiMAX Signal

The complex and flexible burst type frame of the WiMAX signal can be challenging to analyze using general-purpose test equipment. Fortunately, signal analyzers with vector modulation capability offer automatic and adaptable measurements including digital demodulation for IEEE 802.16e-2005 and WiBro compliant waveforms.

A few basic analyzer settings, such as center frequency, frequency span, and input range must be configured before beginning digital demodulation. Following a well-organized measurement approach, it is suggested that vector signal analysis should begin with basic time domain and spectrum measurements. Once spectrum analysis is complete, the analyzer will generally have the proper frequency and amplitude settings that are required to proceed to the demodulation mode of operation.

In addition, these preliminary measurements can uncover problems such as malformed or missing preambles that would prevent successful demodulation but are harder to see in digital demodulation mode. Digital demodulation begins with the assumption that the center frequency, span, and input range are configured correctly for the OFDM signal under test.

Several properties should be configured based on the OFDM signal under test. These include selecting the appropriate standard, nominal bandwidth, and guard interval. Properly configuring these three parameters is necessary for the analyzer to lock on to and demodulate the test signal. In cases where there is some question about the correct value for a parameter, different values can be used on a trial basis (such as the guard interval) or the actual values for a parameter can be determined through the time and frequency domain analysis approaches discussed earlier in this section.

Configuring User Selectable Settings

As part of the demodulation process, you must configure three parameters: the applicable version of the IEEE standard, the nominal bandwidth, and the guard interval.

To begin select **802.16 OFDMA** from the **Mode** menu. Using the **Mode Setup** key, select the **Radio Std** menu, which allows you to choose either of two WiMAX formats, **802.16e-2005** or **WiBro**. Next, the nominal bandwidth for the signal under test must be entered using the front-panel **BW** key, or the **Preset Profile** key in the menu for the radio standard you have selected. There are two ways to enter the value for nominal bandwidth; the first allows the user to manually enter the value into the property box and the second technique allows use of the Up/Down and rotary knob. Finally, you can set the guard interval through use of the **Guard Interval** key found in the **802.16e-2005** and **WiBro** menus.

You can also enter one of eleven standard preset values for 802.16e-2005 and 3 standard presets for WiBro. For the 802.16e-2005 standard, preset bandwidths range from 1.25 to 28 MHz. For WiBro, preset bandwidths range from 4.375 to 17.5 MHz. See the Mode Setup table on [page 167](#) which indicates the values for each WiMAX standard, that you will need to enter for FFT size, BW Ratio, Guard Interval, Frame Duration, and Downlink Ratio. Each of these parameters is accessed through the menu for the WiMAX format you have selected, either through the **802.16e-2005** or **WiBro** menu.

The specified nominal bandwidths are related to the carrier spacing, symbol time, guard interval, and sampling factor. Entering the nominal bandwidth will automatically set the value of several test parameters including the subcarrier spacing and sampling factor (F_s/BW). The nominal bandwidth is a

descriptive term and its value is slightly larger than the actual bandwidth of the outermost carriers of the signal.

If the nominal bandwidth of the signal is not known, a basic spectrum measurement can be used to determine the value. The analyzer has several measurement tools, such as the occupied bandwidth calculation, that can be used when determining the nominal bandwidth.

The guard interval is another parameter that must be set based on the properties of the OFDM signal. In the menu for the WiMAX mode you have selected, you will find the **Guard Interval** key, which accesses a menu of guard interval selections. The default setting is 1/8. If the value is unknown, it can be measured in the time domain using the measured length of the long or short preamble. A preamble symbol has a power level that is 3 dB higher than the data symbol. When examining the beginning of a subframe, it is possible to visually pick out the portion of the preamble from the rest of the subframe. A measurement of the preamble length can be used to determine the guard interval by comparing the measured preamble length to the guard interval selections on the WiMAX Frequency and Time Parameter Table (see [“Appendix A” on page 164](#)).

Observing the Automatic Demodulation Parameters

The analyzer provides defaults for the sampling factor and data subcarrier modulation parameters for the 802.16 OFDMA and WiBro versions of WiMAX. As a rule, in 802.16 OFDMA multiples of 1.25 MHz, 1.5 MHz, 2 MHz, and 2.75 MHz are set to a ratio of 28/25, while multiples of 1.75 MHz, and other bandwidth settings, are set to a ratio of 8/7, which is also the setting for all WiBro bandwidths. The Sampling Factor, identified as BW Ratio, is related to the ratio of OFDM sampling rate to the selected nominal bandwidth. The IEEE 802.16-2005 specification defines this parameter using a set of ratios related to integer multiples of a frequency value. See [Table 6-4 on page 114](#).

Table 6-4 BW Ratio Settings for 802.16 OFDMA and WiBro

| WiMAX Mode | BW | FFT Size | BW Ratio |
|---------------------|-----------|----------|----------|
| 802.16 OFDMA | 1.25 MHz | 128 | 28/25 |
| | 5 MHz | 512 | |
| | 10 MHz | 1024 | |
| | 15 MHz | 1024 | |
| | 20 MHz | 2048 | |
| | 3.5 MHz | 512 | 8/7 |
| | 7 MHz | 1024 | |
| | 8.75 MHz | 1024 | |
| | 14 MHz | 1024 | |
| | 17.5 MHz | 2048 | |
| | 28 MHz | 2048 | |
| | | | |
| WiBro | 4.375 MHz | 512 | |
| | 8.75 MHz | 1024 | |
| | 17.5 MHz | 2048 | |

The analyzer automatically selects the appropriate ratio based on the user input for nominal bandwidth. For example, if the nominal bandwidth is selected as 7 MHz then the sampling ratio will be 8/7, based on the fact that 7 MHz is an integer multiple of 1.75 MHz. The analyzer also provides the option for manual selection of the sampling ratio when prior knowledge of the exact sampling ratio is known for the OFDM signal under test.

The data subcarrier modulation for a OFDM signal can vary between four different modulation types: BPSK, QPSK, 16QAM, and 64QAM. The analyzer is capable of automatically detecting the modulation types within the OFDM burst and displaying the measured results using various traces views such as the constellation display and the Peak/Average Metrics table.

Viewing the Demodulated Data

For a complex signal such as WiMAX, there is a considerable amount of measurement data available once the analyzer has successfully demodulated the OFDM signal. The analyzer provides colorful multi-trace displays that allow you to quickly verify the proper operation of the signal and rapidly identify any problems that may exist. Numerical measurement of modulation quality and visual evaluation of potential errors are easier with the use of these multiple simultaneous displays. Linking measurements across multiple domains also provides a powerful verification and troubleshooting tool.

Verifying and Troubleshooting the Demodulated OFDM signal

Verification that proper demodulation has occurred usually begins with examining a few measurement traces such as the Constellation trace and Symbols/Errors table. A clear constellation is an excellent starting point for indicating a successful demodulation.

Compared to traditional digital modulation formats, the WiMAX constellation may appear to have an unusual configuration. Depending on the structure of the subframe and the number of symbols used in the analysis, the constellation may be comprised of an overlay of BPSK, QPSK, 16QAM, and 64QAM. The analyzer uses a color coding scheme to visually show the different multi-modulation formats simultaneously in the same constellation trace. Here, the constellation is color coded by modulation type. For example, the QPSK part of the constellation is displayed in one color and the BPSK pilot 10 element has another. This color-coding is consistent across different measurement displays, providing valuable troubleshooting insights through correlation of different error measurements as shown below.

Circles are placed around the ideal constellation locations for each modulation type. This size of the circles represents the error vector magnitude (EVM) as a percentage. By default, the circles are set to a 5 percent EVM and this can be adjusted as desired. Measurement points that fall outside the circles are indicative of problems within the OFDM signal or in the demodulation process. As a measurement example, [Figure 6-8 on page 116](#) shows the constellation of a DL subframe containing all possible modulation types over the total of 42 symbols. This constellation is representative of a valid demodulation result but reveals significant errors for the symbols using a 64QAM format. When examining the expanded view in [Figure 6-8](#), it is observed that BPSK pilot and 16QAM data-modulated symbols fall inside the 5 percent EVM circles but none of the 64QAM symbols fall inside the appropriate circles.

This display indicates errors possibly resulting from limiting, scaling, or compression problems that only affect the 64QAM symbols. In this case, it was later found that scaling errors in the DSP resulted in improper amplitude levels for all the 64QAM data symbols, though these scaling errors did not affect the other modulation types. There are several clues to the problem in the constellation, and in other measurements. In the constellation, for example, it can be seen that amplitude errors are proportional to the signal's amplitude (represented by the distance from the center of the constellation) and are not larger for higher-amplitude states such as the corner ones. If the errors were due to amplitude compression in an amplifier, the errors would be much larger for the corner states than for the center ones, and other modulation types would be affected. In addition, the effects of pilot amplitude tracking (see [“Pilot Tracking” on page 140](#)) would provide other information about this error and the modulation with which it is associated.

Figure 6-8 Constellation trace for a WiMAX downlink subframe including a close-up showing large errors for symbols using the 64QAM format (example from the Agilent 89600)

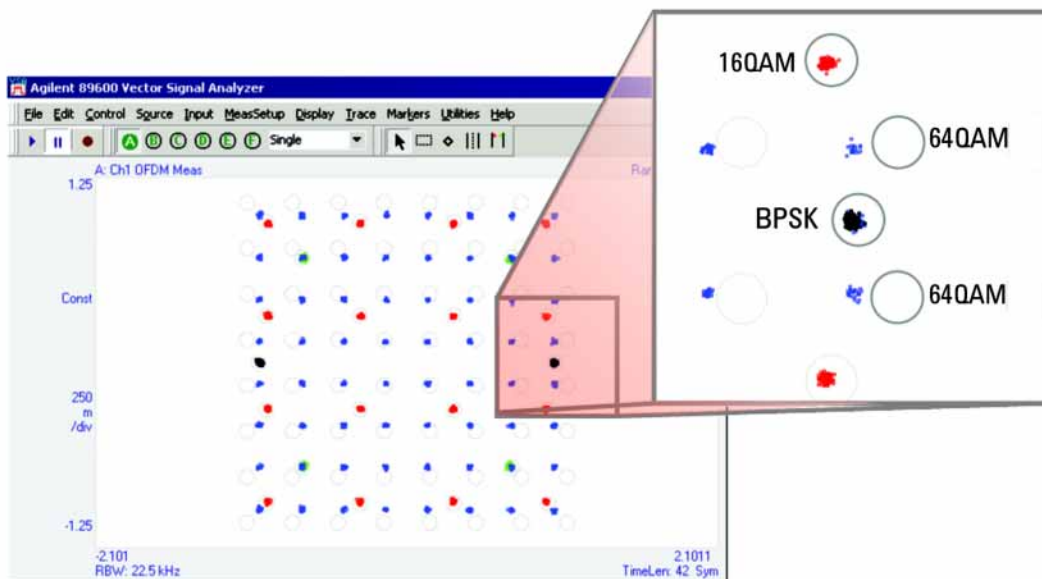

Examining the Peak/Average Metrics Table

The Peak/Average Metrics table is a very useful display. It will help you verify the operation of the analyzer demodulator and the modulation quality of the OFDM signal. This display shows several error statistics for all the demodulated symbols included in the analysis.

Figure 6-9 Peak/Average Metrics Table

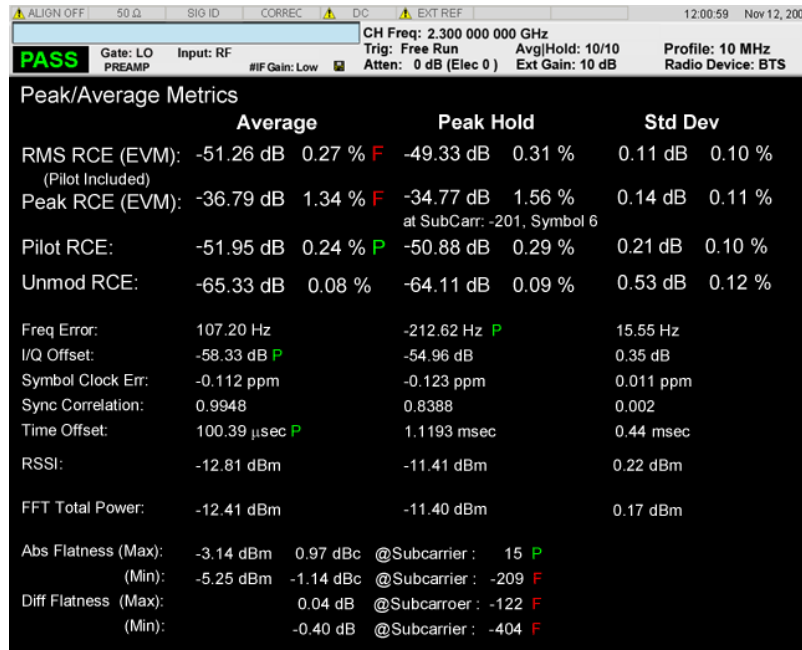

One of the most powerful statistics for determining the modulation quality of the signal is the measured value for Relative Constellation Error (RCE). RCE is defined in the IEEE 802.16 standard as the RMS value of the EVM over the entire burst. The RCE is calculated using all preamble and data symbols in the burst. The RCE is shown as a percentage and as a value in decibels (dB). The 802.16 standard lists the RCE for specific modulation types and coding rates but the RCE value supplied in this summary table provides an overall figure of merit of the modulation quality for the entire WiMAX burst.

The peak level of EVM is shown on this table as Peak RCE. Peak RCE provides both the percentage RCE and the specific value in dB. Peak values that deviate substantially from the total RCE may indicate problems with only a few symbols within the burst.

The Peak/Average table also displays statistics based on errors found within the pilot subcarriers. Pilot subcarriers are used for a continuous demodulation reference during the burst, and therefore it is important to verify the performance of these transmitted subcarriers using composite statistical values such as Pilot RCE.

The frequency error (Freq Error) reported in the table is the value determined from the final frequency estimation based on the channel estimation sequence and any frequency error detected in the pilot tracking. Errors in RF frequency, LO frequency, or digitizer clock rate could all appear as carrier frequency error.

IQ Offset, also displayed in the Peak/Average Metrics view, indicates the magnitude of the carrier feed through. The DC offset tends to reduce the dynamic range of the receiver as well as introduce noise into each subcarrier signal, particularly for high data rate systems. Carrier feed through can also result in

degraded performance in systems that use zero-IF architectures, as the down converted carrier may result in a large DC offset, which would reduce dynamic range in the A/D converters.

OFDM signals differ from single-carrier modulated signals in that these errors cause each subcarrier to interfere with adjacent subcarriers, which can result in the spreading of each constellation point. Spreading of the constellation points results in an increase in EVM and reduced system performance. In some cases, state spreading will spread the points into a distorted miniature picture of the entire constellation, though the structure of the spread points may be impossible to recognize, especially for higher-order modulation types and where the data on frequency-symmetrical carriers is uncorrelated.

The Peak/Average Metrics table also provides a value for the Symbol Clock Frequency Error (Symbol Clock Err), which is the difference between the ideal and actual symbol clock frequency in ppm. A symbol clock frequency that is lower than specified will make the OFDM symbol time longer than required and cause the OFDM subcarrier spacing to decrease. A symbol clock frequency that is greater than specified will make the symbol times shorter than required and cause the OFDM subcarrier spacing to increase. In either case this creates subcarrier interference and increases the signal's EVM. In many cases this will produce a distinctive V-shaped error vector spectrum display if "Track Timing" is not enabled in the pilot tracking of the analyzers demodulator. This pilot tracking function is described in the section Pilot Tracking on page 140.

The Peak/Average Metrics table also shows a figure of merit indicating the quality of the preamble segment used for synchronization and is termed the Sync Corr. Sync Corr is a cross correlation between the measured signal and an ideal signal using the synchronization segment of the preamble. A value of 1 indicates perfect correlation and a value of 0 indicates no correlation. Large frequency errors (approximately 100 kHz or more) may cause the analyzer to show incorrect low Sync Corr values.

These values are a result of frequency error and do not necessarily indicate poor signal quality. Therefore, for low Sync Corr values you always need to validate the cause of the low Sync Corr data result. If the Sync Corr is low and the frequency error is large, check the RCE. If the RCE is low, the measured signal data is good and the low Sync Corr value can generally be ignored. To correct for frequency errors, adjust the center frequency of the analyzer or the transmitter so that the freq err decreases to approximately 0 Hz. If the Sync Corr increases in value, then the contributing factor to the initial low Sync Corr value was the frequency error and not the measured signal.

Verifying and Troubleshooting OFDM signals

Demodulating a complex signal such as WiMAX can lead to problems locking to and troubleshooting the signal under test. Demodulation problems may result from problems found in two categories: problems associated with an improper setting of the instrument and problems inherent to the signal itself. The following troubleshooting information may be useful when problems occur during the initial demodulation setup of the analyzer. It is assumed that basic spectrum and time domain measurements have been successfully made prior to activating signal demodulation.

Uncovering Demodulation Problems

The following is a partial list of possible problems that may be observed when attempting to demodulate a OFDM signal for the first time. Demodulation problems may occur due to signal-related problems or to an incorrectly configured instrument. Incorrect instrument settings often result in a failure to lock onto the signal and result in a poor constellation trace. If the analyzer's center frequency and span, and input range are set correctly, signal-related issues that create problems during digital demodulation can typically be discovered by examining the Peak/Average Metrics table, as well as other views, such as the

Constellation, Symbol Power vs. Subcarrier, and Zone definition views.

This list does not cover all possible causes for demodulation problems but should serve as a guide into the process for uncovering issues with OFDM demodulation. Keep in mind that a well-organized approach to analyzer measurements begins with basic time and spectrum analysis (vector measurements). It has been shown that performing vector measurements prior to digital demodulation can verify the quality of the OFDM signal and ensure that the analyzer has been properly configured.

Table 6-5 WiMAX Problems and Troubleshooting Table

| | |
|------------------|--|
| Problem: | Demodulation fails to lock on signal |
| Symptom: | Bad constellation trace and very high RCE (EVM), but time & spectrum measurements OK. |
| Examine: | The Sync Corr in the Peak/Average Metrics table. If the Sync Corr value is close to then it is possible that the “Guard Interval” is incorrectly set. |
| Solution: | Modify the guard interval. |
| Problem: | Signal is transmitting incorrect pilot bits |
| Symptom: | RCE (EVM) larger than expected. |
| Examine: | The CPE level will be high both in the Pilot RCE in the Peak/Average Metrics table, and in the Common Pilot Error trace. |
| Solution: | Turn off PilotTracking, and possibly Pilot Phase Tracking. |
| Problem: | Signal has longer transition gaps between symbols than expected |
| Symptom: | RCE (EVM) larger than expected. |
| Examine: | The TTG and RTG timing using a time domain trace. |
| Solution: | Change Symbol Timing Adjustment to be more negative. Symbol timing can be modified by accessing the Symbol Timing Adjust parameter, which is located at Meas Setup, More, More, Advanced |
| Problem: | Signal amplitude varies during burst |
| Symptom: | RCE (EVM) larger than expected. |
| Examine: | The Error Vector Time trace shows an increase in EVM from beginning to end of burst. |
| Solution: | Turn on Pilot Amplitude Tracking. Pilot tracking is covered in “Pilot Tracking” on page 140 |
| Problem: | Center frequency of signal not correct |
| Symptom: | Sync Corr value is low, Freq Err is large but RCE is good. |
| Examine: | The Freq Err in the Peak/Average Metrics table, large frequency errors result when the instrument’s center frequency does not match the signals. |
| Solution: | Adjust the center frequency of the analyzer. |

Time Gating Concepts

Introduction: Using Time Gating on a Simplified Digital Radio Signal

This section shows you the concepts of using time gating on a simplified digital radio signal. The section on Making Time-Gated Measurements demonstrates time gating examples.

Figure 6-10 shows a signal with two radios, radio 1 and radio 2, that are time-sharing a single frequency channel. Radio 1 transmits for 1 ms then radio 2 transmits for 1 ms.

Figure 6-10 Simplified Digital Mobile-Radio Signal in Time Domain

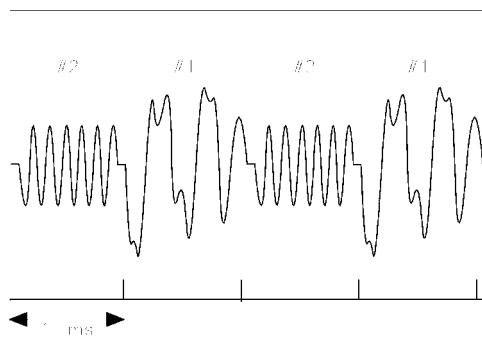

01154e

We want to measure the unique frequency spectrum of each transmitter.

A signal analyzer without time gating cannot do this. By the time the signal analyzer has completed its measurement sweep, which lasts about 50 ms, the radio transmissions switch back and forth 25 times. Because the radios are both transmitting at the same frequency, their frequency spectra overlap, as shown in Figure 6-11. The signal analyzer shows the combined spectrum; you cannot tell which part of the spectrum results from which signal.

Figure 6-11 Frequency Spectra of the Combined Radio Signals

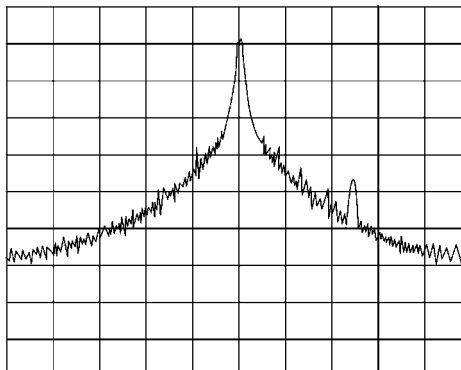

01155e

Time gating allows you to see the separate spectrum of radio 1 or radio 2 to determine the source of the

spurious signal, as shown in [Figure 6-12](#)

Figure 6-12 Time-Gated Spectrum of Radio 1

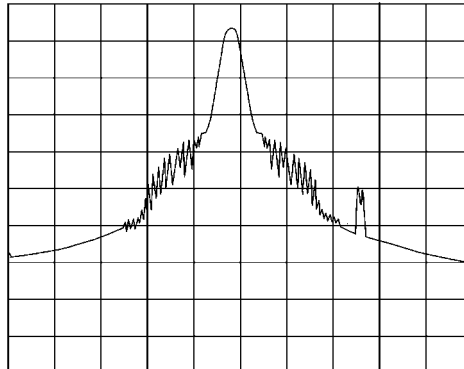
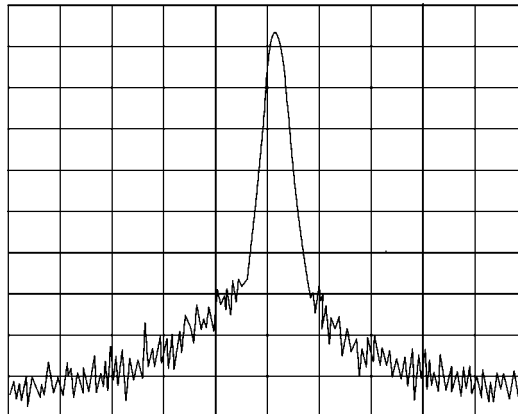

Figure 6-13 Time-Gated Spectrum of Radio 2



Time gating lets you define a time window (or time gate) of when a measurement is performed. This lets you specify the part of a signal that you want to measure, and exclude or mask other signals that might interfere.

How Time Gating Works

Time gating is achieved by the signal analyzer selectively interrupting the path of the detected signal, with a gate, as shown in Figure 6-16 and Figure 6-15. The gate determines the times at which it captures measurement data (when the gate is turned “on,” under the Gate menu, the signal is being passed, otherwise when the gate is “off,” the signal is being blocked). Under the right conditions, the only signals that the analyzer measures are those present at the input to the analyzer when the gate is on. With the correct signal analyzer settings, all other signals are masked out.

There are typically two main types of gating conditions, *edge* and *level*:

- With edge gating, the gate timing is controlled by user parameters (gate delay and gate length) following the selected (rising or falling) edge of the trigger signal. The gate passes a signal on the edge of the trigger signal (after the gate delay time has been met) and blocks the signal at the end of the gate length.

With edge gating, the gate control signal is usually an external periodic TTL signal that rises and falls in synchronization with the rise and fall of the pulsed radio signal. The gate delay is the time the analyzer waits after the trigger event to enable the gate (see Figure 6-14).

- With level gating, the gate will pass a signal when the gate signal meets the specified level (high or low). The gate blocks the signal when the level conditions are no longer satisfied (level gating does not use gate length or gate delay parameters).

Figure 6-14 Edge Trigger Timing Relationships

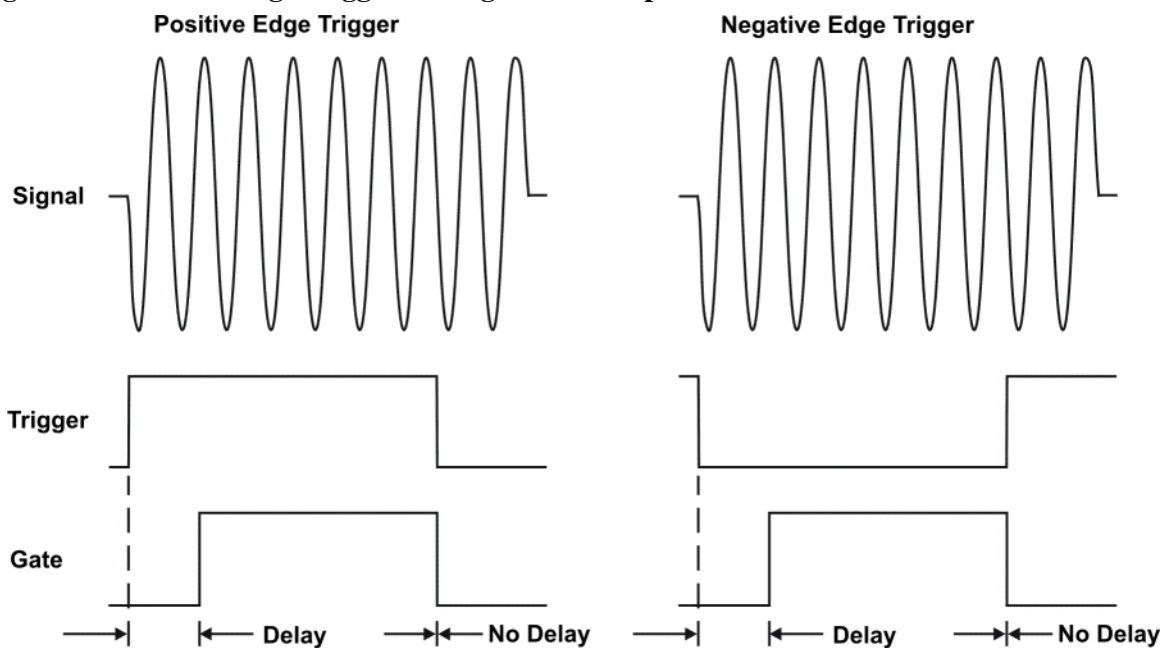

With Agilent signal analyzers, there are three different implementations for time gating: gated LO, gated video and gated FFT.

Gated Video Concepts

Gated video may be thought of as a simple gate switch, which connects the signal to the input of the signal analyzer. When the gate is “on” (under the Gate menu) the gate is passing a signal. When the gate

is “off,” the gate is blocking the signal. Whenever the gate is passing a signal, the analyzer sees the signal. In [Figure 6-15](#) notice that the gate is placed after the envelope detector and before the video bandwidth filter in the IF path (hence “gated video”).

The RF section of the signal analyzer responds to the signal. The selective gating occurs before the video processing. This means that there are some limitations on the gate settings because of signal response times in the RF signal path.

With video gating the analyzer is continually sweeping, independent of the position and length of the gate. The analyzer must be swept at a minimum sweep time (see the sweep time calculations later in this chapter) to capture the signal when the gate is passing a signal. Because of this, video gating is typically slower than gated LO and gated FFT.

Figure 6-15 Gated Video Signal Analyzer Block Diagram

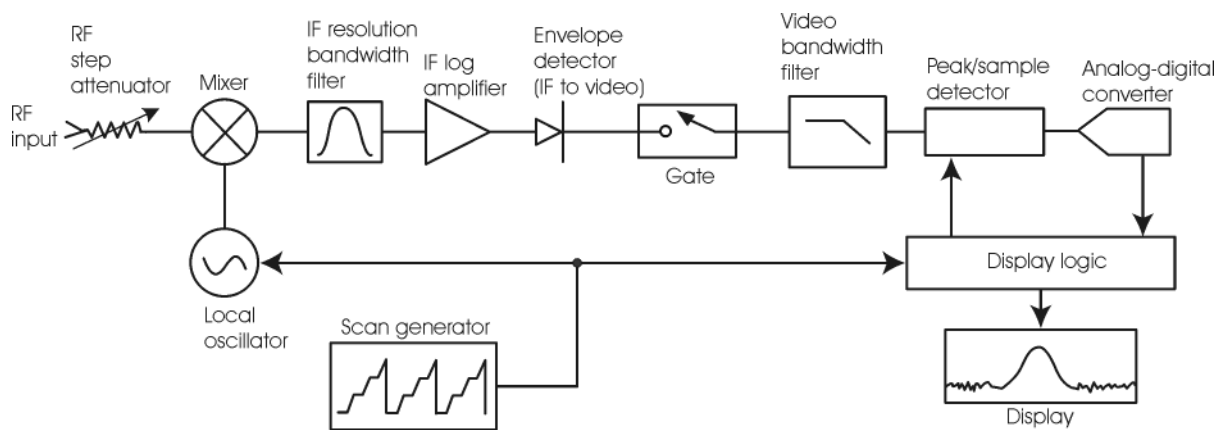

Gated LO Concepts

Gated LO is a very sophisticated type of time gating that sweeps the LO only while the gate is “on” and the gate is passing a signal. See [Figure 6-16](#) for a simplified block diagram of gated LO operation. Notice that the gate control signal controls when the scan generator is sweeping and when the gate passes or blocks a signal. This allows the analyzer to sweep only during the periods when the gate passes a signal. Gated LO is faster than Gated Video because Gated Video must constrain sweep time so that each point is long enough to include a burst event. On the other hand, when in Gated LO, multiple points may be swept during each gate.

Figure 6-16 Gated LO Signal Analyzer Block Diagram

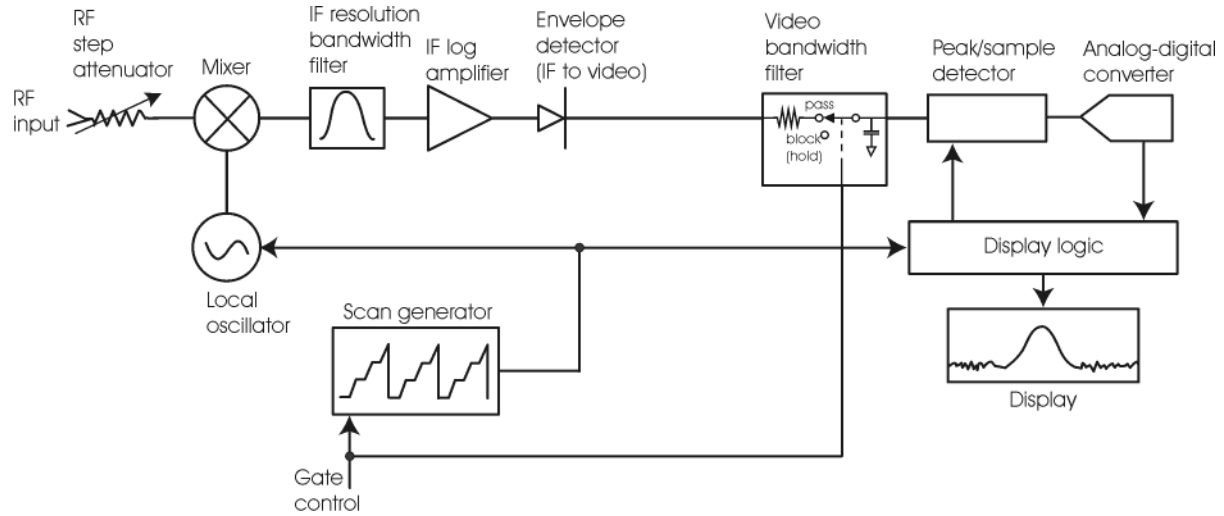

Gated FFT Concepts

Gated FFT (Fast-Fourier Transform) is an FFT measurement which begins when the trigger conditions are satisfied.

The process of making a spectrum measurement with FFTs is inherently a “gated” process, in that the spectrum is computed from a time record of short duration, much like a gate signal in swept-gated analysis.

Using the analyzer in FFT mode, the duration of the time record to be gated is:

$$\text{FFT Time Record (to be gated)} = \frac{1.83}{\text{RBW}}$$

The duration of the time record is within a tolerance of approximately 3% for resolution bandwidths up through 1 MHz. Unlike swept gated analysis, the duration of the analysis in gated FFT is fixed by the RBW, not by the gate signal. Because FFT analysis is faster than swept analysis (up to 7.99 MHz), the gated FFT measurements can have better frequency resolution (a narrower RBW) than swept analysis for a given duration of the signal to be analyzed.

Figure 6-17 Gated FFT Timing Diagram

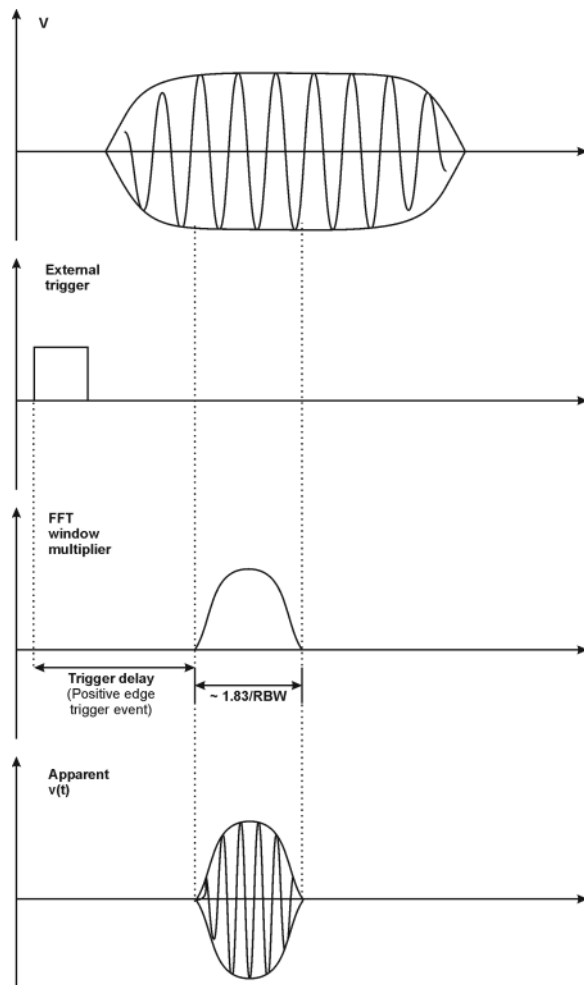

Time Gating Basics (Gated LO and Gated Video)

The gate passes or blocks a signal with the following conditions:

- Trigger condition - Usually an external transistor-transistor logic (TTL) periodic signal for edge triggering and a high/low TTL signal for level triggering.
- Gate delay - The time after the trigger condition is met when the gate begins to pass a signal.
- Gate length - The gate length setting determines the length of time a gate begins to pass a signal.

To understand time gating better, consider a spectrum measurement performed on two pulsed-RF signals sharing the same frequency spectrum. You will need to consider the timing interaction of three signals with this example:

- The composite of the two pulsed-RF signals.
- The gate trigger signal (a periodic TTL level signal).
- The gate signal. This TTL signal is low when the gate is “off” (blocking) and high when the gate is “on” (passing).

Concepts

Time Gating Concepts

The timing interactions between the three signals are best understood if you observe them in the time domain (see [Figure 6-18](#)).

The main goal is to measure the spectrum of signal 1 and determine if it has any low-level modulation or spurious signals.

Because the pulse trains of signal 1 and signal 2 have almost the same carrier frequency, their spectra overlap. Signal 2 will dominate in the frequency domain due to its greater amplitude. Without gating, you won't see the spectrum of signal 1; it is masked by signal 2.

To measure signal 1, the gate must be on only during the pulses from signal 1. The gate will be off at all other times, thus excluding all other signals. To position the gate, set the gate delay and gate length, as shown in [Figure 6-18](#), so that the gate is on only during some central part of the pulse. Carefully avoid positioning the gate over the rising or falling pulse edges. When gating is activated, the gate output signal will indicate actual gate position in time, as shown in the line labeled "Gate."

Figure 6-18 Timing Relationship of Signals During Gating

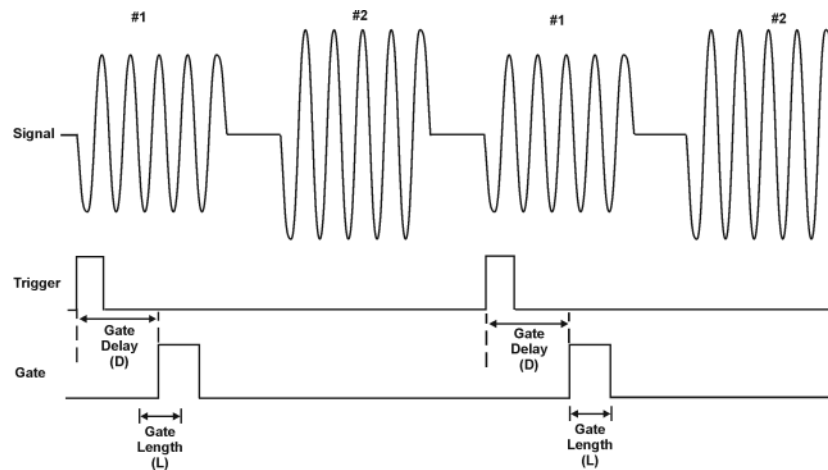

Once the signal analyzer is set up to perform the gate measurement, the spectrum of signal 1 is visible and the spectrum of signal 2 is excluded, as shown in [Figure 6-20](#). In addition, when viewing signal 1, you also will have eliminated the pulse spectrum generated from the pulse edges. Gating has allowed you to view spectral components that otherwise would be hidden.

Figure 6-19 Signal within pulse #1 (time-domain view)

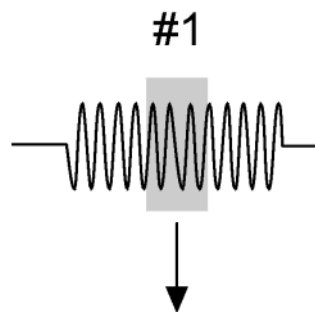

aj159e

Figure 6-20 Using Time Gating to View Signal 1 (spectrum view)

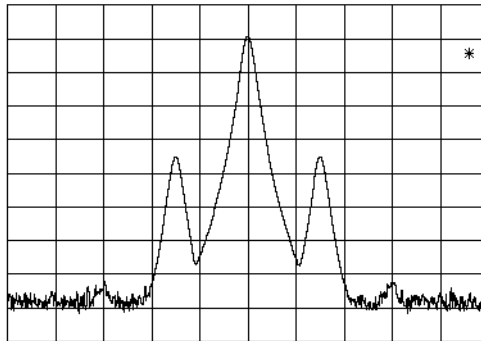

Moving the gate so that it is positioned over the middle of signal 2 produces a result as shown in [Figure 6-22](#). Here, you see only the spectrum within the pulses of signal 2; signal 1 is excluded.

Figure 6-21 Signal within pulse #2 (time-domain view)

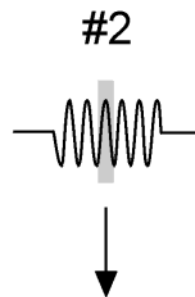

aj160e

Figure 6-22 Using Time Gating to View Signal 2 (spectrum view)

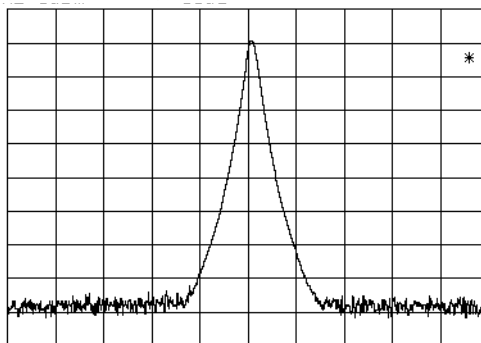

Measuring a Complex/Unknown Signal

NOTE

The steps below help to determine the signal analyzer settings when using time gating. The steps apply to the time gating approaches using gated LO and gated video.

This example shows you how to use time gating to measure a very specific signal. Most signals requiring time gating are fairly complex and in some cases extra steps may be required to perform a measurement.

Step 1. Determine how your signal under test appears in the time domain and how it is

Concepts

Time Gating Concepts

synchronized to the trigger signal.

You need to do this to position the time gate by setting the delay relative to the trigger signal. To set the delay, you need to know the timing relationship between the trigger and the signal under test. Unless you already have a good idea of how the two signals look in the time domain, you can examine the signals with an oscilloscope to determine the following parameters:

- Trigger type (edge or level triggering)
- Pulse repetition interval (PRI), which is the length of time between trigger events (the trigger period).
- Pulse width, or τ
- Signal delay (SD), which is the length of time occurring between the trigger event and when the signal is present and stable. If your trigger occurs at the same time as the signal, signal delay will be zero.

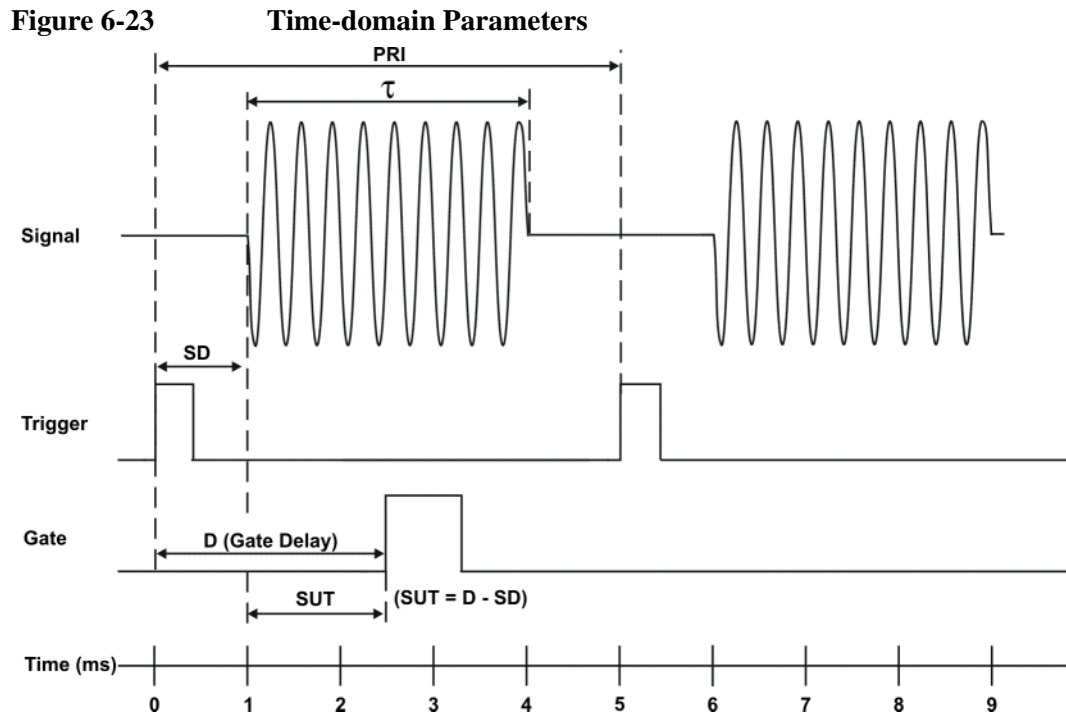

In [Figure 6-23](#), the parameters are:

- Pulse repetition interval (PRI) is 5 ms.
- Pulse width (τ) is 3 ms.
- Signal delay (SD) is 1 ms for positive edge trigger (0.6 ms for negative edge trigger).
- Gate delay (D) is 2.5 ms.
- Setup time (SUT) is 1.5 ms.

Step 2. Set the signal analyzer sweep time:

Gated LO: Sweep time does not affect the results of gated LO unless the sweep time is set too fast. In

the event the sweep time is set too fast, Meas Uncal appears on the screen and the sweep time will need to be increased.

Gated Video: Sweep time does affect the results from gated video. The sweep time must be set accordingly for correct time gating results. The recommended sweep time is at least the number of *sweep points* – 1 multiplied by the *PRI* (*pulse repetition interval*). Measurements can be made with sweep times as fast as $(\text{sweep points} - 1) * (\text{PRI} - \tau)$.

Step 3. Locate the signal under test on the display of the signal analyzer. Set the center frequency and span to view the signal characteristics that you are interested in measuring. Although the analyzer is not yet configured for correct gated measurements, you will want to determine the approximate frequency and span in which to display the signal of interest. If the signal is erratic or intermittent, you may want to hold the maximum value of the signal with **Max Hold** (located under the **Trace/Detector** menu) to determine the frequency of peak energy.

To optimize measurement speed in the Gated LO case, set the span narrow enough so that the display will still show the signal characteristics you want to measure. For example, if you wanted to look for spurious signals within a 200 kHz frequency range, you might set the frequency span to just over 200 kHz.

Step 4. Determine the setup time and signal delay to set up the gate signal. Turn on the gate and adjust the gate parameters including gate delay and gate length as shown below.

Generally, the gate should be positioned over a part of the signal that is stable, not over a pulse edge or other transition that might disturb the spectrum. Starting the gate at the center of the pulse gives a setup time of about half the pulse width. Setup time describes the length of time during which that signal is present and stable before the gate comes on. The setup time (SUT) must be long enough for the RBW filters to settle following the burst-on transients. Signal delay (SD) is the length of time after the trigger, but before the signal of interest occurs and becomes stable. If the trigger occurs simultaneously with the signal of interest, SD is equal to zero, and SUT is equal to the gate delay. Otherwise, SUT is equal to the gate delay minus SD. See [Figure 6-24](#)

Figure 6-24

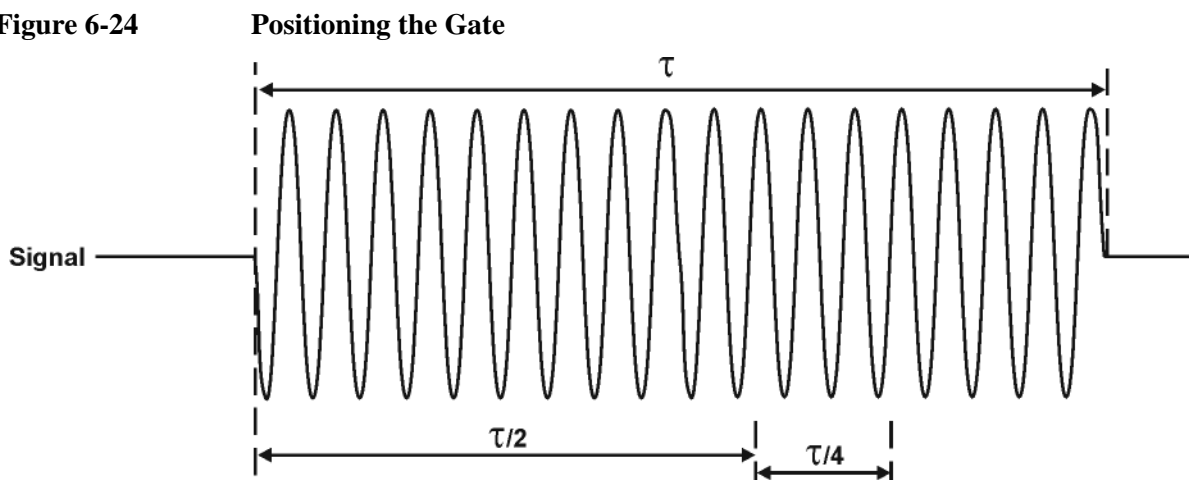

There is flexibility in positioning the gate, but some positions offer a wider choice of resolution bandwidths. A good rule of thumb is to position the gate from 20 % to 90 % of the burst width. Doing so

provides a reasonable compromise between setup time and gate length.

Figure 6-25 Best Position for Gate

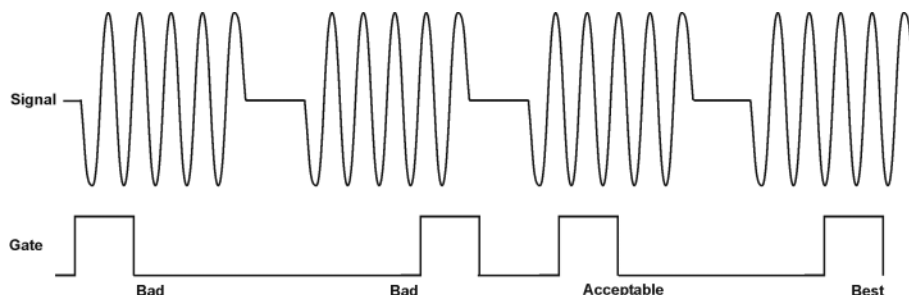

As a general rule, you will obtain the best measurement results if you position the gate relatively late within the signal of interest, but without extending the gate over the trailing pulse edge or signal transition. Doing so maximizes setup time and provides the resolution bandwidth filters of the signal analyzer the most time to settle before a gated measurement is made. “Relatively late,” in this case, means allowing a setup time of at least $3.84/\text{resolution bandwidth}$ (see [step 5](#) for RBW calculations).

As an example, if you want to use a 1 kHz resolution bandwidth for measurements, you will need to allow a setup time of at least 3.84 ms.

Note that the signal need not be an RF pulse. It could be simply a particular period of modulation in a signal that is continuously operating at full power, or it could even be during the off time between pulses. Depending on your specific application, adjust the gate position to allow for progressively longer setup times (ensuring that the gate is not left on over another signal change such as a pulse edge or transient), and select the gate delay and length that offer the best representation of the signal characteristics of interest on the display.

If you were measuring the spectrum occurring between pulses, you should use the same (or longer) setup time after the pulse goes away, but before the gate goes on. This lets the resolution bandwidth filters fully discharge the large pulse before the measurement is made on the low-level interpulse signal.

Figure 6-26 Setup Time for Interpulse Measurement

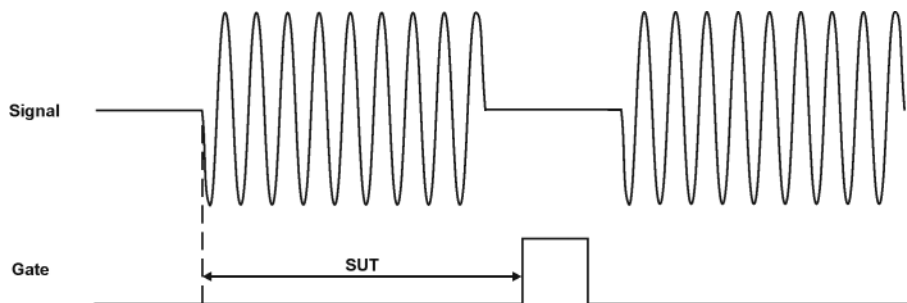

Step 5. The resolution bandwidth will need to be adjusted for gated LO and gated video. The video bandwidth will only need to be adjusted for gated video.

Resolution Bandwidth:

The resolution bandwidth you can choose is determined by the gate position, so you can trade off longer setup times for narrower resolution bandwidths. This trade-off is due to the time required for the resolution-bandwidth filters to fully charge before the gate comes on. Setup time, as mentioned, is the

length of time that the signal is present and stable before the gate comes on.

Figure 6-27 Resolution Bandwidth Filter Charge-Up Effects

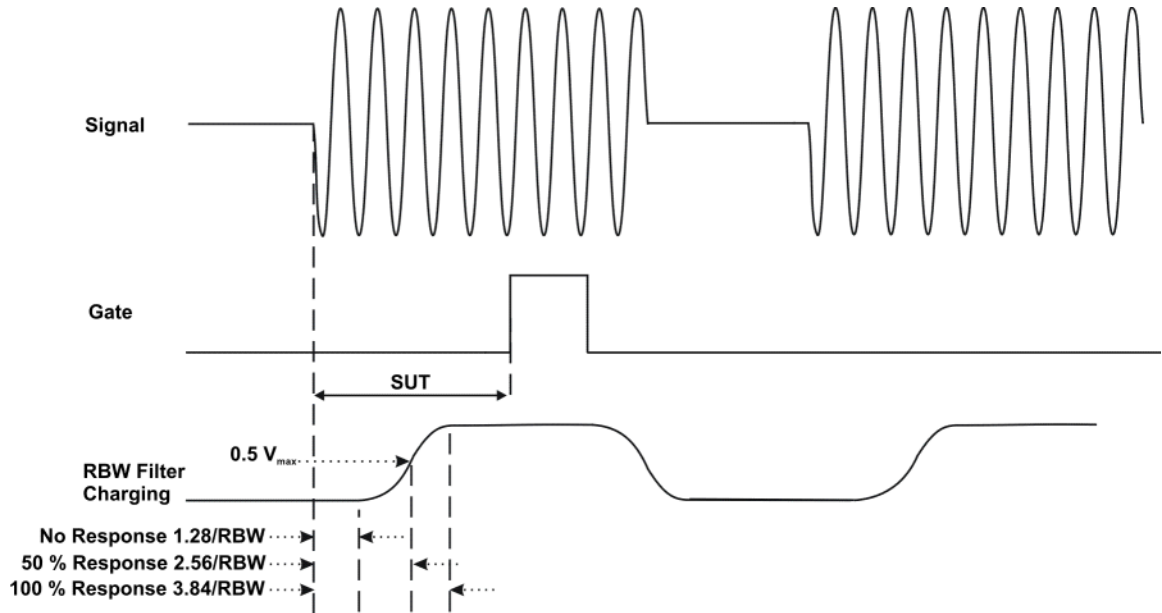

Because the resolution-bandwidth filters are band-limited devices, they require a finite amount of time to react to changing conditions. Specifically, the filters take time to charge fully after the analyzer is exposed to a pulsed signal.

Because setup time should be greater than filter charge times, be sure that: $SUT > \frac{3.84}{RBW}$

where SUT is the same as the gate delay in this example. In this example with SUT equal to 1.5 ms, RBW is greater than 2.56 kHz; that is, RBW is greater than 1333 Hz. The resolution bandwidth should be set to the next larger value, 2.7 kHz.

Video Bandwidth:

For gated LO measurements the VBW filter acts as a track-and-hold between sweep times. With this behavior, the VBW does not need to resettle on each restart of the sweep.

Step 6. Adjust span as necessary, and perform your measurement.

The analyzer is set up to perform accurate measurements. Freeze the trace data by activating single sweep, or by placing your active trace in view mode. Use the markers to measure the signal parameters you chose in step 1. If necessary, adjust span, but do not decrease resolution bandwidth, video bandwidth, or sweep time.

“Quick Rules” for Making Time-Gated Measurements

This section summarizes the rules described in the previous sections.

Table 1. Determining Signal Analyzer Settings for Viewing a Pulsed RF Signal

| Signal Analyzer Function | Signal Analyzer Setting | Comments |
|-------------------------------|--|---|
| Sweep Time (gated video only) | Set the sweep time to be equal to or greater than $(\text{number of sweep points} - 1) \times \text{pulse repetition interval (PRI)}$: | Because the gate must be on at least once per trace point, the sweep time should be set such that the sweep time for each trace point is greater than or equal to the pulse repetition interval. |
| Gate Delay | The gate delay is equal to the signal delay plus one-fourth the pulse width: $\text{Gate Delay} = \text{Signal Delay} + \tau/5$ | The gate delay must be set so that the gating captures the pulse. If the gate delay is too short or too long, the gating can miss the pulse or include resolution bandwidth transient responses. |
| Gate Length | The gate length minimum is equal to one-fourth the pulse width (maximum about one-half): $\text{Gate Length} = 0.7 \times \tau/4$ | If the gate length is too long, the signal display can include transients caused by the signal analyzer filters. The recommendation for gate placement can be between 20 % to 90 % of the pulse width. |
| Resolution Bandwidth | Set the resolution bandwidth: $\text{RBW} > 19.5/\tau$ | The resolution bandwidth must be wide enough so that the charging time for the resolution bandwidth filters is less than the pulse width of the signal. |

Figure 6-28

Gate Positioning Parameters

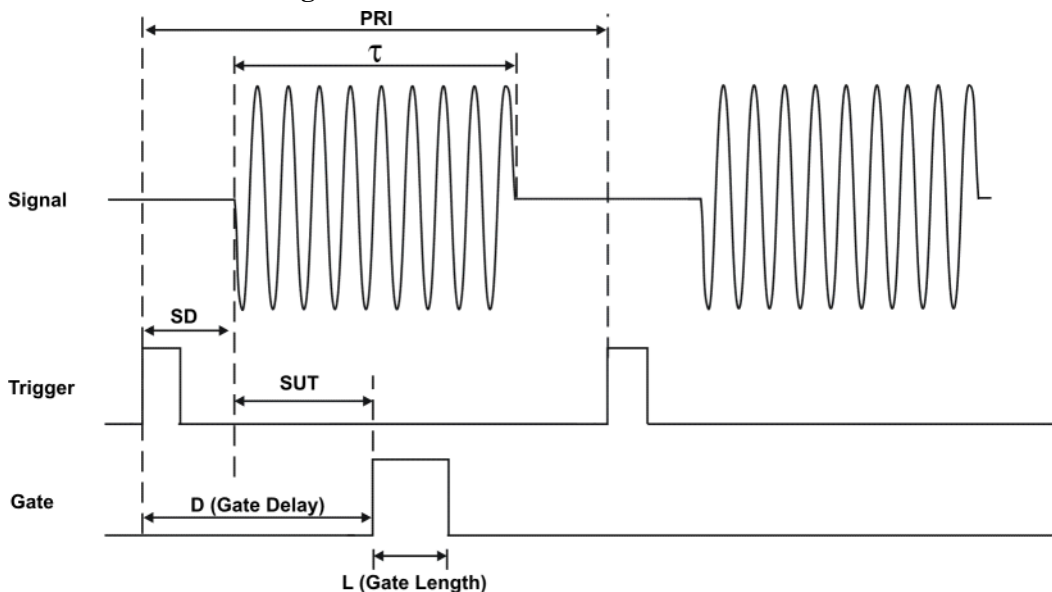

Most control settings are determined by two key parameters of the signal under test: the pulse repetition interval (PRI) and the pulse width (τ). If you know these parameters, you can begin by picking some standard settings. Table 2. summarizes the parameters for a signal whose trigger event occurs at the same time as the beginning of the pulse (in other words, SD is 0). If your signal has a non-zero delay, just add it to the recommended gate delay.

Table 2. Suggested Initial Settings for Known Pulse Width (τ) and Zero Signal Delay

| Pulse width (τ) | Gate Delay ($SD + \tau/5$) | Resolution Bandwidth ($>19.5/\tau$) | Gate Length ($0.7 \times \tau/4$) |
|------------------------|------------------------------|---------------------------------------|-------------------------------------|
| 4 μ s | 0.8 μ s | 4.875 MHz | 0.7 μ s |
| 10 μ s | 2 μ s | 1.95 MHz | 1.753 μ s |
| 50 μ s | 10 μ s | 390 kHz | 8.75 μ s |
| 63.5 μ s | 12.7 μ s | 307 kHz | 11.11 μ s |
| 100 μ s | 20 μ s | 195 kHz | 17.5 μ s |
| 500 μ s | 100 μ s | 39 kHz | 87.5 μ s |
| 1 ms | 200 μ s | 19.5 kHz | 0.175 μ s |
| 5 ms | 1 ms | 3.9 kHz | 0.875 ms |
| 10 ms | 2 ms | 1.95 kHz | 1.75 ms |
| 16.6 ms | 3.32 ms | 1.175 kHz | 2.905 ms |
| 33 ms | 6.6 ms | 591 Hz | 5.775 ms |
| 50 ms | 10 ms | 390 Hz | 8.75 ms |
| 100 ms | 20 ms | 195 Hz | 17.5 ms |
| ≥ 130 ms | 26 ms | 151 Hz | 22.75 ms |

Table 3. If You Have a Problem with the Time-Gated Measurement

| Symptom | Possible Causes | Suggested Solution |
|--|---|---|
| Erratic analyzer trace with dropouts that are not removed by increasing analyzer sweep time; oscilloscope view of gate output signal jumps erratically in time domain. | Gate Delay may be greater than trigger repetition interval. | Reduce Gate Delay until it is less than trigger interval. Check Gate View to make sure the gate delay is timed properly. |
| Gate does not trigger. | 1) Gate trigger voltage may be wrong. 2) Gate may not be activated. 3) Gate Source selection may be wrong. | With external gate trigger: ensure that the trigger threshold is set near the midpoint of the waveform (view the waveform on and oscilloscope using high input impedance, not 50 Ω). With RF Burst Gate Source: ensure that the start and stop frequencies are within 10 MHz of the center frequency of the carrier. Check to see if other connections to trigger signal may be reducing voltage. If using an oscilloscope, check that all inputs are high impedance, not 50 Ω . |
| Display spectrum does not change when the gate is turned on. | Insufficient setup time. | Increase setup time for the current resolution bandwidth, or increase resolution bandwidth. |
| Displayed spectrum too low in amplitude. | Resolution bandwidth or video bandwidth filters not charging fully. | Widen resolution bandwidth or video bandwidth, or both. |

Using the Edge Mode or Level Mode for Triggering

Depending on the trigger signal that you are working with, you can trigger the gate in one of two separate modes: edge or level. This gate-trigger function is separate from the normal external trigger capability of the signal analyzer, which initiates a sweep of a measurement trace based on an external signal.

Edge Mode

Edge mode lets you position the gate relative to either the rising or falling edge of a trigger signal. The left diagram of Figure 6-29 shows triggering on the positive edge of the trigger signal while the right diagram shows negative edge triggering.

Example of key presses to initiate positive edge triggering:
Press **Sweep, Gate, More, Polarity (Pos)**.

Figure 6-29 Using Positive or Negative Edge Triggering

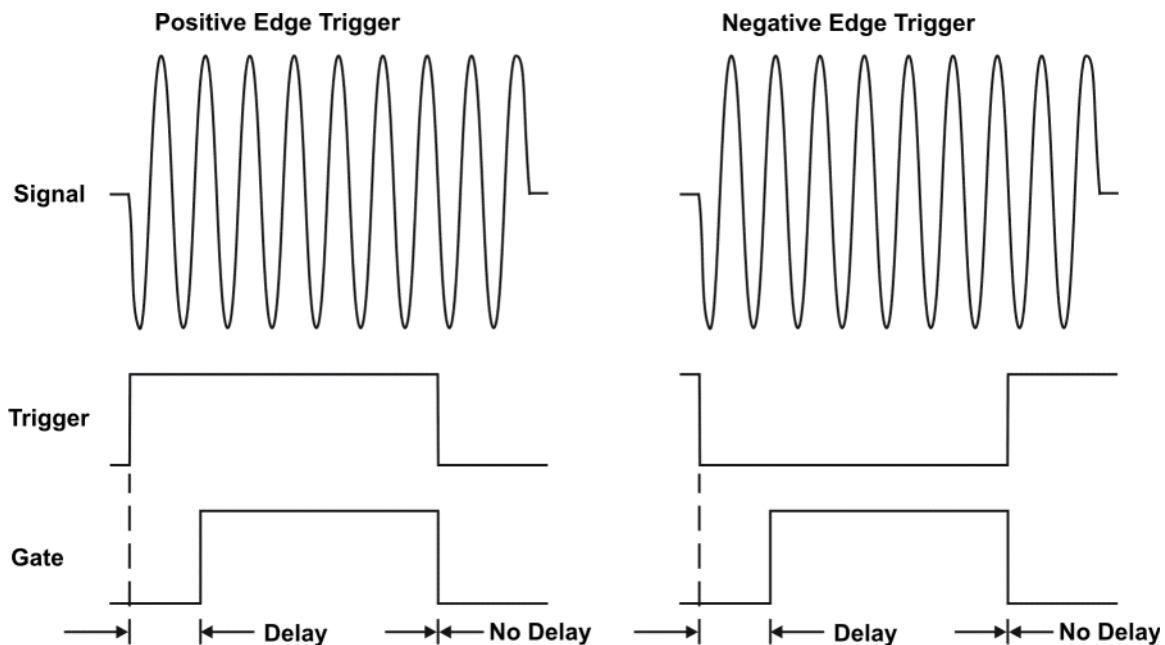

Level Mode

In level gate-control mode, an external trigger signal opens and closes the gate. Either the TTL high level or TTL low level opens the gate, depending on the setting of **Trig Slope**. Gate delay affects the start of the gate but not the end. Gate length is applicable when using level mode triggering. Level mode is useful when your trigger signal occurs at exactly the same time as does the portion of the signal you want to measure.

Noise Measurements Using Time Gating

Time gating can be used to measure many types of signals. Noise and noise-like signals are often a special case in spectrum analysis. With the history of gated measurements, these signals are especially noteworthy.

The average detector is the best detector to use for measuring noise-like signals because it uses all the available noise power all the time in its measurement. The sample detector is also a good choice because it, too, is free from the peak biases of the peak detector, normal and negative peak detectors.

When using the average or sample detector, noise density measurements using the noise marker or band/interval density marker can be made without any consideration of the use of gating--gated measurements work just as well as non-gated measurements. Thus, the average detector is recommended for noise density measurements.

Older analyzers only had the gated video version of gating available, and these only worked with the peak detector, so the rest of this section will discuss the trade-offs associated with trying to replicate these measurements with an MXA.

Unlike older analyzers, MXA can make competent measurements of noise density using the noise marker with all detectors, not just those that are ideal for noise measurements. Thus, MXA can make noise density measurements with peak detection, compensating for the extent to which peak detection increases the average response of the analyzer to noise. When comparing a gated video measurement using the noise marker between MXA and an older analyzer where both use the peak detector, the MXA answer will be approximately correct, while the older analyzer will need a correction factor. That correction factor is discussed in Agilent Technologies Application Note 1303, Spectrum Analyzer Measurements and Noise, in the section on Peak-detected Noise and TDMA ACP Measurements.

When making measurements of Band/Interval Power or Band/Interval Density, the analyzer does not make compensations for peak detection. For best measurements with these marker functions, average or sample detection should be used.

Troubleshooting Symbols and Improving Demodulation

Demodulating Specific Time and Frequency Intervals

Time and frequency (vector) analysis of a WiMAX waveform can be easily performed by this signal analyzer. This analyzer is capable of demodulating the RF burst and measuring the signal quality in multiple domains including subcarrier frequency and symbol-time. Analysis of specific time and frequency intervals can also provide isolation of signal errors or impairments within the complex structure of the WiMAX waveform.

Analyzing Specific Time Intervals

Demodulation of specific time intervals can be used to identify impulsive, intermittent, or periodic sources of errors.

As a measurement example, [Figure 6-30 on page 138](#) shows the Constellation, Error Vector Time, Error Vector Spectrum, and Symbols/Errors traces for the eight pilot subcarriers in the FCH symbol. As WiMAX uses these pilots to correct for time varying errors in the received signal (and thus the demodulation is performed relative to the pilots), it is important that the modulation quality of these symbols be very high.

Analyzing Specific Frequency Intervals

Demodulation of specific frequency intervals within the WiMAX subframe is another powerful analytic and troubleshooting tool. This feature provides the isolation of errors down to the individual subcarrier as a function of symbol time and can be used to identify such problems as interference, spurious, and DSP errors.

When selecting the option for a specific subcarrier, it is also necessary to enter the subcarrier index from among the 200 possible subcarriers used in the WiMAX subframe. The subcarrier indexing begins at -100 and ends at 100 . The index equal to zero is not used as this value represents the RF carrier of the signal and contains only a leakage term. Demodulating the individual subcarriers allows for the comparison of data subcarriers with pilot subcarriers.

This technique is very useful when troubleshooting DSP problems. As a measurement example, [Figure 6-30 on page 138](#) shows the Error Vector Time and Error Vector Spectrum for a single subcarrier from an UL subframe. The upper two traces show the errors for a single pilot subcarrier with index = -88 . Here, the Error Vector Time trace (upper left) shows a maximum EVM value of 2.7 percent. Also note that the EVM as a function of symbol-time does not change significantly over the complete subframe.

As a comparison, the lower two traces show the errors for the data subcarrier with index = 10 . The Error Vector Time trace (lower left) for this data subcarrier has a large EVM peak error of approximately 12 percent. Also note that this trace shows a large jump in the EVM for the symbols at the end of the subframe. This figure confirms that errors are occurring in the selected data sub carrier and not the pilot subcarrier. It can also be determined using the analyzer's modulation specific color-coding scheme, that the large errors are confined to the 64QAM symbols at the end of the subframe. It was later discovered that these errors are related to scaling problems in the DSP. This technique is also a very useful tool when troubleshooting OFDM signals when problems arise as a result of time-variant effects such as turn on/off

Concepts
Troubleshooting Symbols and Improving Demodulation

settling, thermal, and power supply related problems.

Figure 6-30 Error Vector Time and Error Vector Spectrum traces using a single WiMAX frequency subcarrier. The upper pair of traces shows the results for the pilot subcarrier at index = -88. The lower pair shows the results for a data subcarrier at index = 10 (example from Agilent 89600)



Correcting Signal Imperfections

As in many OFDM-based communications systems, the IEEE 802.16 standard includes specific provisions for adaptive equalization and pilot tracking within the receiver. These provisions improve receiver performance by correcting for linear errors, including impairments such as amplitude and delay distortion. These errors can arise from phenomena such as multipath that may occur in the wireless channel between the transmitter and the receiver, or by frequency response problems in the transmitter or receiver circuitry.

Adaptive equalization is initially used during the demodulation process to correct for frequency dependent errors contained in the received signal. Conversely, pilot tracking continuously corrects for time-varying errors that occur over the length of the OFDM subframe. Adaptive equalization and pilot tracking are particularly useful for broadband OFDM signals where the nominal bandwidth can be as large as 28 MHz and the opportunity for frequency response problems is correspondingly greater than that for more narrowband signals. Adaptive equalization and pilot tracking are designed to work together in the receiver, and to be complimentary, enabling the use of denser constellations and thus yielding higher data rates.

These features also work together in this signal analyzer providing important signal information and troubleshooting tools as shown in the following examples.

Training the Equalizer

In the WiMAX system, a training sequence composed of predetermined values is modulated onto the OFDM subcarriers at a specific time in the subframe called “channel estimation”. The receiver can improve the quality of the demodulated data by adaptively adjusting coefficients in the equalizer based on prior knowledge of the transmitted signal. The coefficients correct for linear amplitude and phase errors that occur as a result of multipath in the wireless channel or problems that may occur in the transmitter or receiver circuitry.

Equalization of the DL subframe usually occurs during the second symbol of the long preamble. This OFDM symbol is comprised of 100 subcarriers placed at every even index value. The UL subframe also uses 100 subcarriers placed at even indexes and is transmitted as a single OFDM symbol in the short preamble. Midambles may also be present and useful for updating the equalizer coefficients during the subframe.

The use of an explicit training sequence is not the only way for a receiver to compute equalizer coefficients. In some cases the transmitted data itself can be analyzed to determine the characteristics of the channel and transmitter. This technique is sometimes called data-directed equalization. For some systems, data directed equalization in a receiver provides many useful advantages.

In general, the quality of the calculated equalizer coefficients is better if more data is used to calculate them. Specifically, if signal variance due to noise is the primary mechanism limiting the quality of the calculations, the noise in the received signal that impairs the ability of the receiver to calculate coefficients is proportional to the square root of the number of independent samples of data in the training sequence.

For example, using 25 data symbols from a subframe would be significantly better than using the one channel estimation sequence of a DL subframe, as the noise variance would be 3.5 times smaller. Note that the DL channel estimation sequence actually consists of two repetitions of a waveform in time, therefore the noise variation falls by the square root of the ratio $25/2$.

The analyzer supports three ways to initialize, or “train,” the instrument’s equalizer. One is based on the

Channel Estimation Sequence Only. The second is based on using both the Channel Estimation Sequence and the Data. The third is based on using both the Channel Estimation Sequence and the Pilot. Switching between the three training types can help isolate problems contributing to increased RCE (EVM). For example, the measured RCE of a signal with a malformed preamble would be much larger when only the preamble was used to train the equalizer. To access Equalizer training selections follow this path: **Meas Setup, More, Advanced, Equalizer Training**.

The Chan Estimation Seq Only option on this analyzer results in training the equalizer coefficients on the channel estimation sequence in the preamble, and holds the coefficients constant while demodulating the rest of the subframe. This option models how a typical WiMAX receiver would train its coefficients. In this case, the measured RCE (EVM) more accurately reflects the signal quality seen by a typical OFDM receiver. This method also complies with the IEEE 802.16 standard for testing the transmitter constellation error. The disadvantage of this method is that the measured RCE (EVM) value may be higher for signals whose impairments change during the burst.

The second option for training the equalizer coefficients is the Chan Estimation Seq & Data method. For this option the equalizer is trained by analyzing the entire subframe, which includes the channel estimation sequence (contained in the preamble) and all the data symbols. This type of training generally results in a more accurate estimate of the true frequency response of the transmission channel. In addition, the RCE (EVM) is typically lower because noise and other forms of distortion, such as turn-on transients, have less of an impact when calculating the filter coefficients in the equalizer. The disadvantage of this method is that it is less likely to accurately reflect the performance of a typical OFDMA receiver.

The third option for training the equalizer coefficients is the Chan Estimation Seq & Pilot method. For this option the equalizer is trained by analyzing the entire OFDMA burst, which includes the channel estimation sequence (contained in the preamble) and the Pilot symbols. This type of training, like the Chan Estimation Seq & Data method, results in a more accurate estimate of the response of the transmission channel, and has the additional advantage of being in compliance with IEEE 802.16e-2005, section 8.4.12.3.2. However, this method also is less likely to reflect the performance of a typical OFDMA receiver, and is also more complicated, and may be less cost-efficient, for application with practical receivers.

Conventional single-carrier systems often require complex equalization techniques in order to overcome multipath-induced ISI and signal fading. The OFDM multi-carrier based system uses a cyclic prefix and long symbol times relative to the channel impulse response in order to overcome multipath effects. In addition, frequency selective fading in the wireless channel is typically localized to a subset of carriers (each of which experiences essentially flat fading) that are relatively easy to equalize in comparison to a single-carrier modulated system.

Once calculated, the equalizer coefficients remain fixed for the duration of the subframe. For signal variations within the subframe, the 802.16 standard provides a method of tracking these variations using the pilot subcarriers. Pilots are present in each OFDM symbol including the FCH and all data bursts. The next section will show the performance improvements that can be achieved using pilot tracking.

Pilot Tracking

When demodulating an OFDM burst, the equalizer response computed from the preamble is used to correct many flaws in the received OFDM signal. Because the equalizer response is not perfect and because some signal impairments are not correctable through equalization, pilot tracking is used to correct for imperfections in the equalizer response and for imperfections that change over the length of the burst. These pilots are used, in part, to create a continuous series of amplitude and phase references

throughout the subframe. Demodulation is then performed relative to these pilot subcarriers and allows a variety of signal impairments to be corrected continuously throughout the RF burst. For example, once the frequency reference of the receiver is set by the signals in the preamble, pilot-tracking algorithms can continuously adjust the receiver phase reference to track out close-in phase noise. The same is true for amplitude errors, where the receiver ALC is set during the preamble and time-dependent amplitude changes due to thermal effects or droop are tracked out during the rest of the burst.

In each WiMAX OFDM symbol, eight subcarriers are dedicated to pilot signals in order to make the coherent detection robust against frequency offsets and symbol timing variations or phase noise. These pilots occupy subcarrier indexes of -88 , -63 , -38 , -13 , 13 , 38 , 63 , and 88 and always use BPSK modulation. Pilot subcarriers are transmitted with a known data sequence. This information is used to determine the difference, or error, between an ideal signal and the actual received signal. Because the data is complex, the analyzer can calculate the phase, amplitude, and timing errors in the received data and then use this information to correct both pilot and data imperfections.

The error vector magnitude of the eight pilot subcarriers is reported as the Pilot Relative Constellation Error (RCE) in the Peak/Average Metrics table using the signal analyzer. The IEEE 802.16 standard uses the term RCE instead of EVM, but the computed values are exactly the same. The Pilot RCE is calculated as the RMS value of the EVM (in dB) of the eight pilot subcarriers for all symbols over the entire burst. The value reported for Pilot RCE is determined after equalization and pilot tracking have been applied.

This analyzer provides the capability to select a tracking type using the amplitude, phase, and timing, or any combination of the three. These pilot tracking features are accessed through the **Meas Setup, More Advanced, Pilot Tracking** keys.

As discussed previously, the Pilot RCE shows the resulting EVM after equalization and tracking have been applied to the demodulated pilot signals. Alternatively, the actual errors or impairments that result from tracking the pilot subcarriers are collectively called Common Pilot Error (CPE). The CPE is expressed as a function of symbol-time showing how the amplitude and phase error of the pilots can change over the OFDM burst. Ideally, the CPE trace data has a magnitude of one and phase of zero. The CPE trace data is measured at each symbol-time over all eight pilot subcarriers. The errors from ideal are averaged together producing a single complex value at each symbol-time.

Fortunately, close-in phase noise can be tracked out of the signal using the pilot tracking function. The amplitude response of the CPE shows an increase in the pilot error during the early part of this subframe. This rapid increase in the pilot amplitude error is the result of amplitude droop occurring over the subframe. Possible causes for this error could be thermal or power supply related problems in the RF amplifier of the WiMAX transmitter. A marker placed on the amplitude response shows that the maximum CPE occurs at symbol 29 with a value of 0.35 dB. A marker placed on the peak phase response shows a value of 0.4 degrees at symbol 19 showing that peak errors are not necessarily coincident between the various responses.

In addition to selecting amplitude and phase tracking of the pilots, it is also possible to track timing. Timing errors may be caused by both analog and digital sources. For example, oscillator frequency errors or DSP errors such as an improper number of samples in the guard interval or improper sample rate may create large timing errors, which often require pilot tracking to correct. The Pilot Track Timing parameter specifies whether the analyzer tracks timing changes in the pilot subcarriers. When Pilot Track Timing is selected the analyzer applies pilot subcarrier timing error correction (frequency offset correction) to the pilot and data subcarriers.

The analyzer provides one additional timing adjustment at the point of demodulation in the OFDM symbol: the Symbol Timing Adjust adjustment. The OFDM symbol time consists of a guard interval plus an FFT length. The Symbol Timing Adjust parameter allows the user to move the FFT length's starting position within the full OFDM symbol. No specific time position is called out in the IEEE 802.16 standard, and different timing settings may affect the measured demodulation quality. In particular, if ISI or multipath signals affect the guard interval, certain offsets in symbol timing may result in improved signal demodulation.

Using the analyzer, the Symbol Timing Adjust parameter is expressed as a percentage of the TFFT length. This parameter makes the point of demodulation within the symbol time back up into the symbol and guard interval. The minimum value in percentage is equal to $-(\text{Guard Interval value}) \times 100$ and the maximum value is zero. The default value is -3.125 percent if the guard interval is $1/16$ or greater and $-(\text{Guard Interval value}) \times 100 \div 2$, if less than $1/16$. The Symbol Time Adjust parameter can be accessed by following this path: **Meas Setup, More, More, Advanced.**

Uncovering IQ Errors

Digitally modulated systems that use IQ vector modulators to impress the information onto an RF carrier all experience some level of signal distortion due to imperfections in the IQ modulator and associated components. Impairments such as IQ gain imbalance, IQ quadrature skew and IQ channel mismatch will all lead to distortion in the received signal that may reduce the overall system performance.

It is important to note that the observed effects resulting from IQ impairments will often look different for single-carrier modulated signals when compared to OFDM modulated signals.

Analog IQ modulators always have some degree of imbalance of amplitude and phase between the I and Q channels. Gain mismatch or gain imbalance will result in the amplitude of one channel being smaller than the other.

Gain imbalance will alter the constellation of an OFDM modulated signal much differently from that of a single-carrier modulated signal. In a single-carrier modulated signal, the gain imbalance results in a visible distortion in the constellation, as a square constellation would become rectangular. In an OFDM modulated signal, the imbalance will result in a spreading of the constellation points similar to a signal experiencing noisy conditions.

An imbalance in an OFDM modulator produces two error terms in the transmitted signal. The first error occurs at one subcarrier frequency ($+k$ th index) and the second error occurs at the frequency mirror-image subcarrier ($-k$ th index). As the data is generally uncorrelated on these subcarriers and the constellation points for OFDM signals is a function of subcarrier frequency rather than time, the randomness in error terms results in the spreading of the constellation states in a noise-like fashion.

As a measurement example showing the effects of IQ imbalance, [Figure 6-31 on page 144](#) shows constellation plots for a single-carrier modulated waveform (upper trace) and an OFDM modulated waveform (lower trace). Both waveforms use 64QAM data modulation. As shown, the single carrier modulated signal shows a distortion in the constellation, as the values along the Q-axis become larger than values along the I-axis resulting in a rectangular-shaped constellation.

Alternately, the constellation points for the OFDM –modulated signal show a more noise- like distribution. Also shown on the lower trace are the pilot subcarriers that are present in all OFDM symbols. It is shown that the distribution of constellation points for the pilot subcarriers follow a linear pattern along the I-axis when there exists an IQ imbalance. As the pilot subcarriers use BPSK modulation and do not contain an imaginary term, the imbalance errors introduce a linear spreading

along the I-axis as shown in [Figure 6-31](#).

Figure 6-31 Constellation traces for single-carrier (upper trace) and OFDM (lower traces) modulated signals with IQ gain imbalance. Single-carrier Modulation OFDM Modulation pilot subcarriers (example from the Agilent 89600.)

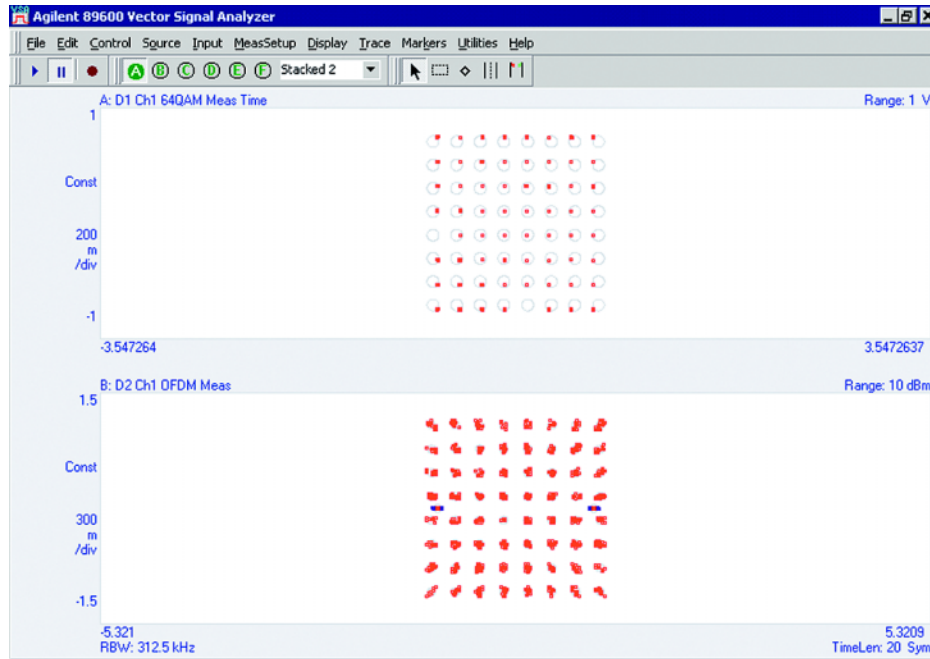

Quadrature Skew Error (Quad Err) is another IQ modulator impairment that indicates an orthogonal error between the I and Q signals. Ideally, I and Q channels should be exactly orthogonal (90 degrees apart). For small angular errors, it can be shown that the resulting error is orthogonal to the data. As with gain imbalance, the error generates energy at the subcarrier and its mirror image and the resulting constellation for data subcarriers again appears to have a noise-like distribution. For the BPSK pilots, the error again produces a linear distribution but this time in the orthogonal axis or Q-axis.

IQ Offset, also called “I/Q origin offset” or “carrier leakage”, indicates the magnitude of the carrier feed through and is measured during the channel estimation sequence portion of the preamble. IQ Offset can be observed as an offset in the constellation or shown as a single value in dB in the Peak/Average Metrics view. When there is no carrier feed through, the IQ offset is zero (-infinity dB).

Additional IQ modulator impairments can be analyzed by examining their effects on the constellation trace using the analyzer. Table 6-6 shows a variety of impairments and the anticipated effect on the measurement trace. The table includes waveforms using OFDM and single-carrier modulation, noting that errors in the constellation may have a different appearance for each modulation type.

Table 6-6 Signal Impairments and their Effect on the Displayed Constellation

| Impairment | OFDM | Single-carrier modulation |
|-------------------------------|--|--|
| IQ gain balance | State spreading (uniform/carrier) Distortion of constellation | Distortion of constellation |
| IQ quadrature skew | State spreading (uniform/carrier) | Distortion of constellation |
| IQ channel mismatch | State spreading (nonuniform/carrier) | State spreading |
| Uncompensated frequency error | State spreading | Spinning constellation |
| Phase noise | State spreading (uniform/carrier) | Constellation phase arcing |
| Nonlinear distortion | State spreading | State spreading (may be more pronounced on outer states) |
| Linear distortion | Usually no effect (equalized) | State spreading if not equalized |
| Carrier leakage | Offset constellation for center carrier only (if used) | Offset constellation |
| Frequency error | State spreading | Constellation phase arcing |
| Amplifier droop | Radial constellation distortion | Radial constellation distortion |
| Spurious | State spreading or shifting of affected carrier | State spreading, generally circular |

802.16 OFDMA Measurement Concepts

The following concept sections explain the purpose, and provide descriptions of the measurement method, for the following:

- Adjacent Channel Ratio Measurement
- Channel Power Measurement
- IQ Waveform Measurement
- Modulation Analysis Measurement
- Monitor Spectrum Measurement
- Occupied Bandwidth Measurement
- Power Stat CCDF Measurement
- Power vs. Time Measurement
- Spectrum Emission Mask Measurement
- Spurious Emissions Measurement

See [page 163](#) at the end of this section for a list of sources for further information relevant to WiMAX measurements. Also see “[References](#)” on [page 181](#).

Adjacent Channel Power Ratio (ACPR/ACLR) Measurement Concepts

Purpose

Adjacent Channel Power Ratio (ACPR) is the power contained in a specified frequency channel bandwidth relative to the total carrier power. It may also be expressed as a ratio of power spectral densities between the carrier and the specified offset frequency band. This is also called Adjacent Channel Leakage power Ratio (ACLR).

As a composite measurement of out-of-channel emissions, ACPR combines both in-band and out-of-band specifications to provide useful figures-of-merit for spectral regrowth and emissions produced by components and circuit blocks without the rigor of performing a full spectrum emissions mask measurement.

To maintain a quality call by avoiding channel interference, it is important to measure and reduce any adjacent channel leakage power transmitted from a mobile phone. The characteristics of adjacent channel leakage power are mainly determined by the transmitter design, particularly the low-pass filter.

What Is Adjacent Channel Interference?

Depending on the context, the acronym ACP(R) has been taken to mean either adjacent channel power (ratio), which is a transmitter measurement or adjacent channel protection (ratio), which is a receiver measurement. To resolve this ambiguity, 3GPP has introduced three new terms: adjacent channel leakage power ratio (ACLR), adjacent channel selectivity (ACS), and adjacent channel interference ratio (ACIR).

ACLR is a measure of transmitter performance. It is defined as the ratio of the transmitted power to the power measured after a receiver filter in the adjacent RF channel. This is what was formerly called adjacent channel power ratio.

ACS is a measure of receiver performance. It is defined as the ratio of the receiver filter attenuation on the assigned channel frequency to the receiver filter attenuation on the adjacent channel frequency.

ACIR is a measure of overall system performance. It is defined as the ratio of the total power transmitted from a source (BS or UE) to the total interference power resulting from both transmitter and receiver imperfections affecting a victim receiver. ACIR is mainly of interest in network simulation where the total amount of interference, rather than the source of the interference, is the primary concern.

The following equation shows the relationship between ACIR, ACLR, and ACS:

Equation 6-1 Relationship Between ACIR, ACLR, and ACS

$$\text{ACIR} = \frac{1}{\frac{1}{\text{ACLR}} + \frac{1}{\text{ACS}}}$$

The main source of adjacent channel leakage (ACL) is non-linear effects in the power amplifiers (PA). It directly affects the co-existing performance of systems on adjacent channels. Power leakage is a general noise pollution and degrades performance of the system in the adjacent channel. If sufficiently bad, it causes the so called “near-far” problem, where a UE simply cannot communicate with a far away BS because of high ACL from a nearby adjacent channel UE. Network planning can address this problem, but the associated costs depend directly on the stringency of the ACLR specification. So, we have conflicting needs. From an equipment design perspective, a relaxed ACLR specification is attractive, whereas from a network planning perspective, low ACL is very desirable.

Measurement Method

This ACPR measurement analyzes the total power levels within the defined carrier bandwidth and at given frequency offsets on both sides of the carrier frequency. This measurement requires the user to specify measurement bandwidths of the carrier channel and each of the offset frequency pairs up to 5. Each pair may be defined with unique measurement bandwidths.

It uses an integration bandwidth (IBW) method that performs a time domain data acquisition and applies FFT to get a frequency domain trace. In this process, the channel integration bandwidth is analyzed using the automatically defined resolution bandwidth (RBW), which is much narrower than the channel bandwidth. The measurement computes an average power of the channel over a specified number of data acquisitions, automatically compensating for resolution bandwidth and noise bandwidth.

ACLR (or ACPR) is commonly measured using a signal analyzer or measuring receiver. In the measurement, filtering is applied to both the power in the main frequency channel and the power in the adjacent channel. An important factor for ACLR is the specification of the measurement filter, including its bandwidth and shape.

If **Total Pwr Ref** is selected as the measurement type, the results are displayed as relative power in dBc and as absolute power in dBm. If **PSD Ref** (Power Spectral Density Reference) is selected, the results are displayed as relative power in dB, and as absolute power in dBm/Hz.

Channel Power Measurement Concepts

Purpose

The Channel Power measurement is a common test used in the wireless industry to measure the total transmitted power of a radio within a defined frequency channel. This procedure measures the total power within the defined channel bandwidth. This measurement is applied to design, characterize, evaluate, and verify transmitters and their components or devices for base stations and mobile stations.

Measurement Method

The Channel Power measurement reports the total transmitted power within the selected channel integration bandwidth. The measurement acquires a number of points representing the input signal in the time domain. It transforms this information into the frequency domain using FFT and then calculates the channel power. The effective resolution bandwidth of the frequency domain trace is proportional to the number of points acquired for FFT. The fastest FFT process is achieved using a number of acquired points that is a power of 2 (for example: 64, 128, 512).

Since the measurement is optimized for speed and accuracy, you are permitted to change only the number of acquired data points in powers of 2, not the actual resolution bandwidth which is shown in gray. However, if absolute sweep time is required, it can be changed to the user's specific value at the expense of reduced speed. At no time will both sweep time and data points be set to manual because of conflicting parameter settings. This flexibility is available through the **Advanced** menu of the channel power measurement.

To improve repeatability, you can increase either the number of averages or the number of data points with longer time record length. The channel power graph is shown in the graph window, while the absolute channel power in dBm and the mean power spectral density in dBm/Hz are shown in the text window.

IQ Waveform (Time Domain) Measurement Concepts

Purpose

The waveform measurement is a generic measurement for viewing the input signal waveforms in the time domain. This measurement is how the instrument performs the zero span functionality found in traditional spectrum analyzers.

Basic mode waveform measurement data may be displayed using either a Signal Envelope window, or an I/Q window which shows the I and Q signal waveforms in parameters of voltage versus time. The advantage of having an I/Q view available while making a waveform measurement is that it allows you to view complex components of the same signal without changing settings or measurements.

For the E4406A, an I/Q Polar display is also available to view the I and Q waveforms in a polar plot. This display shows the instantaneous relationship between the I and Q waveform voltages.

The waveform measurement can be used to perform general purpose power measurements in the time domain with excellent accuracy.

Measurement Method

The instrument makes repeated power measurements at a set frequency, similar to the way a swept-tuned spectrum analyzer makes zero span measurements. The input analog signal is converted to a digital

signal, which then is processed into a representation of a waveform measurement. The measurement relies on a high rate of sampling to create an accurate representation of a time domain signal.

Modulation Analysis Concepts

Purpose

The Modulation Analysis measurement provides a full set of demodulation analysis properties that support OFDM scalable parameters including data tone modulation, frame length, nominal bandwidth, BW ratio, guard interval, and FFT size. The analyzer is designed to support downlink and uplink subframe modulation analysis. This measurement provides an overall indication of the performance level of the transmitter that is designated as the UUT (unit under test).

This measurement takes into account all possible error mechanisms in the entire transmission chain including: baseband filtering, I/Q modulation anomalies, filter amplitude and phase non-linearities, and power amplifier distortions.

This measurement covers the following metrics:

- IQ Meas constellation measurement data (includes multiple formats when present)
- Auto detected format: BPSK, QPSK, 16QAM, 64QAM (color coded for display)
- Subchannelization supported
- RCE vs. Time and Frequency
- Preamble Frequency err (used to show frequency settling)
- Data burst information (modulation format, size and burst power)

Measurement Method

To understand the measurement method used in generating modulation analysis results it will be useful to consider two elements of the modulation process that are involved in WiMAX modulation analysis: EVM calculations and OFDM data burst analysis.

EVM Calculations The modulation analysis measurement relies heavily on EVM calculations. The instrument samples the transmitter output in order to capture the actual phase trajectory. This is demodulated, then the ideal phase trajectory is mathematically derived using detected bits and channel filtering. Subtracting one from the other results in a phase error signal.

[Figure 6-32](#) demonstrates how EVM is calculated. The phase error of the unit under test is measured by computing the difference between the phase of the transmitted signal and the phase of a theoretically perfect signal.

Figure 6-32 EVM Calculation

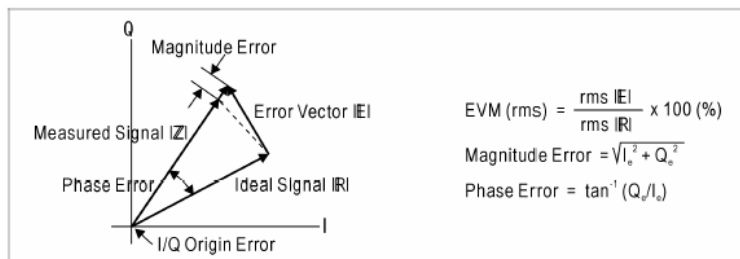

OFDMA Data Burst Analysis The modulation analysis measurement supports two schema of data burst analysis. One schema detects the modulation/encoding scheme of every data burst using DL-MAP/UL-MAP and DCD/UCD messages. The other specifies data burst definitions through a MAP file, which is manually defined or imported by the user.

Downlink and uplink burst allocation maps are transmitted with DL-MAP and UL-MAP messages. Information for the DL-MAP is contained in the DL Frame Prefix in the FCH. This measurement analyzes the FCH (frame control header).

Figure 6-33 OFDMA Frame Structure

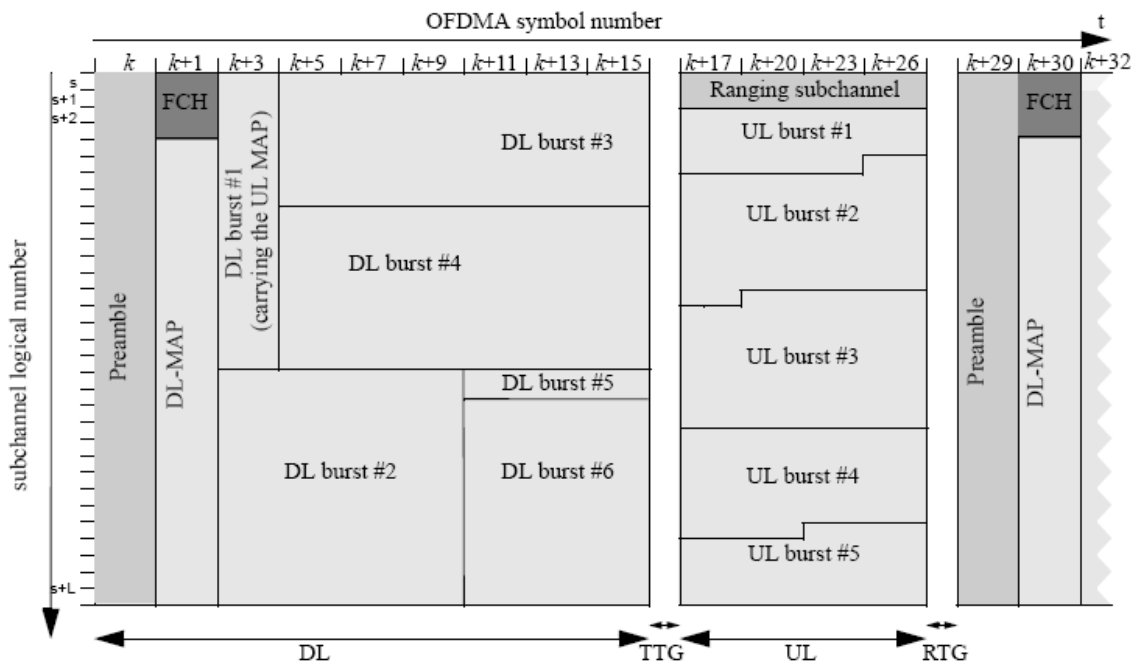

The FCH is transmitted using QPSK rate 1/2 with 4 repetitions using the mandatory coding scheme (e.g., the FCH information will be sent on four adjacent subchannels) in a PUSC zone. The FCH contains the

DL_Frame_Prefix message, and specifies the length of the DL-MAP message that immediately follows the DL_Frame_Prefix and the repetition coding used for the DL-MAP message. Detail of DL_Frame_Prefix can be gotten from section 8.4.4.3 of IEEE Std 802.16.

User Definition Using a Map File The user specifies data burst definitions through a MAP file. This MAP file may be defined by the user through the GUI or may be imported from a different user. One or more data bursts within a single zone are defined using a subchannel by symbol index grid.

Figure 6-33 on page 150 shows an example of a typical IEEE802.16 OFDMA frame structure. The OFDMA frame consists of one or more zones, and each zone have one or more data bursts. A zone spans over physically adjacent symbol intervals. In 802.16-OFDMA, a DL-MAP or UL-MAP message in the PHY layer defines the data bursts present in the frame, and all bursts' modulation and encoding scheme is described in a DCD message.

Spectral Flatness The WiMAX Modulation Analysis measurement is particularly useful for analysis of spectral flatness across all subcarriers, using the preamble as a basis for specifying spectral flatness. See Table 6-7, "Specifications for WiMAX Spectral Flatness," on page 151 for specifications for monitor spectrum flatness.

During normal system operation, all uplink and downlink transmissions begin with a preamble. The preamble is critical because receivers rely on these preambles to synchronize with the transmitter and perform various channel estimation and equalization processes. The preamble uses QPSK modulation and has no embedded BPSK pilots. Because of this, the preamble is ideally suited to specify spectral flatness across all the subcarriers. The 802.16-2004 standard states that data shall be taken from the "channel estimation step", which is the preamble. The specification states, "the absolute difference between adjacent subcarriers shall not exceed 0.1 dB". In the preamble, because only half or one-fourth of the 200 subcarriers are actually used, adjacent carrier spacing in the preamble is wider than data bursts.

Table 6-7 Specifications for WiMAX Spectral Flatness

| Spectral Lines | Spectral Flatness |
|---|--|
| Spectral Lines from -50 to -1 and +1 to +50 | +/-2 dB from the measured energy averaged over all active tones |
| Spectral Lines from -100 to -1 and +1 to +100 | +/-2 dB /-4 dB from the measured energy averaged over all active tones |
| Adjacent Subcarriers | +/- 0.1 dB |

Monitor Spectrum Measurement Concepts

Purpose

The monitor spectrum measurement provides spectrum analysis capability for the instrument. The control of the measurement was designed to be familiar to those who are accustomed to using traditional swept spectrum analyzers. An example is shown in Figure 6-34 on page 152.

This measurement is FFT (Fast Fourier Transform) based. The FFT-specific parameters are located in the **Advanced** menu. Also available under basic mode spectrum measurements is an I/Q window, which shows the I and Q signal waveforms in parameters of voltage versus time.

Figure 6-34 Monitor Spectrum Measurement Result w/ RF Burst Trigger

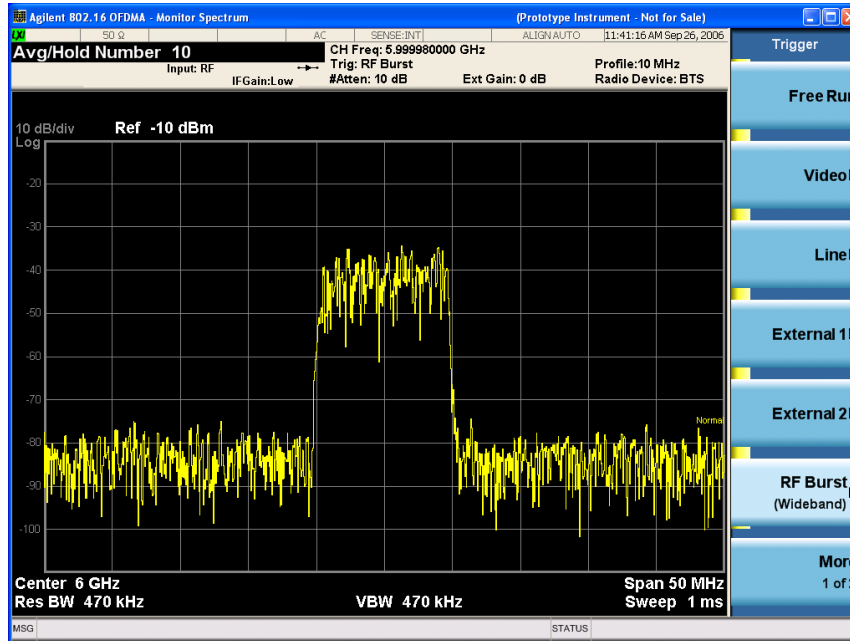

Measurement Method

The measurement uses digital signal processing to sample the input signal and convert it to the frequency domain. With the instrument tuned to a fixed center frequency, samples are digitized at a high rate, converted to I and Q components with DSP hardware, and then converted to the frequency domain with FFT software.

Troubleshooting Hints

Changes made by the user to advanced spectrum settings, particularly to ADC range settings, can inadvertently result in spectrum measurements that are invalid and cause error messages to appear. Care needs to be taken when using advanced features.

Occupied Bandwidth Measurement Concepts

Purpose

Occupied bandwidth measures the bandwidth containing 99.0 of the total transmission power.

Measurement Method

The instrument uses digital signal processing (DSP) to sample the input signal and convert it to the frequency domain. With the instrument tuned to a fixed center frequency, samples are digitized at a high rate with DSP hardware, and then converted to the frequency domain with FFT software.

The total absolute power within the measurement frequency span is integrated for its 100% of power.

The lower and upper frequencies containing 0.5% each of the total power are then calculated to get 99.0% bandwidth.

Power Stat CCDF Measurement Concepts

Purpose

Many of the digitally modulated signals now look noise-like in the time and frequency domain. This means that statistical measurements of the signals can be a useful characterization. Power Complementary Cumulative Distribution Function (CCDF) curves characterize the higher level power statistics of a digitally modulated signal. The curves can be useful in determining design parameters for digital communications systems.

The power statistics CCDF measurement can be affected by many factors. For example, modulation filtering, modulation format, combining the multiple signals at different frequencies, number of active codes, and correlation between symbols on different codes with spread spectrum systems will all affect measurement results. These factors are all related to modulation and signal parameters. External factors such as signal compression and expansion by nonlinear components, group delay distortion from filtering, and power control within the observation interval also affect the measurement.

Both the amplifier designer and the system integrator must make sure that the PA (and other components) can handle the PAR that the signal exhibits for the different data rates, while maintaining a good ACL performance. You can use the complementary cumulative distribution function to help you with this job.

The complementary cumulative distribution function (CCDF) fully characterizes the power statistics of a signal [15].

CCDF curves can help you in several situations:

- To determine the headroom required when designing a component.
- To confirm the power statistics of a given signal or stimulus. CCDF curves allow you to verify if the stimulus signal provided by another design team is adequate. For example, RF designers can use CCDF curves to verify that the signal provided by the digital signal processing (DSP) section is realistic.
- To confirm that a component design is adequate or to troubleshoot your subsystem or system design, you can make CCDF measurements at several points of a system. For example, if the ACLR of a transmitter is too high, you can make CCDF measurements at the input and output of the PA. If the PA design is correct, the curves will coincide. If the PA compresses the signal, the PAR of the signal is lower at the output of the PA.

Measurement Method

The power measured in power statistics CCDF curves is actually instantaneous envelope power defined by the equation:

$$P = (I^2 + Q^2)/Z_0$$

(where I and Q are the quadrature voltage components of the waveform and Z_0 is the characteristic impedance).

A CCDF curve is defined by how much time the waveform spends at or above a given power level. The percent of time the signal spends at or above the level defines the probability for that particular power level. For capturing a lower probability down to 0.0001%, this measurement is made in the single mode by setting **Measure** under **Meas Control** to **Single**. To make the power statistics CCDF measurement, the instrument uses digital signal processing (DSP) to sample the input signal in the channel bandwidth.

The Gaussian distribution line as the band-limited Gaussian noise CCDF reference line, the user-definable reference trace, and the currently measured trace can be displayed on a semi-log graph. If the currently measured trace is above the user reference trace, it means that the higher peak power levels against the average power are included in the input signal.

Power vs. Time Measurement Concepts

Purpose

The Power vs. Time measurement examines the time domain burst shape to determine if the incoming signal satisfies the test limit profile (called the “limit mask”) as it is defined according to the selected mode. The limit mask is configurable

Measurement Method

This measurement acquires the signal in the time domain using the IQ data capture method, then calculates the power vector (magnitude square vector) from the I/Q vector. The measurement algorithm then searches the power vector for a burst that specifies the given burst detection parameters.

If a customer wants to verify the signal against an external timing source, the burst detection function can be disabled. In this case, the customer provides an external trigger signal to the instrument, and the measurement uses the timing of the external trigger as the reference of the burst position.

Once the burst is detected and its timing is located, the algorithm then applies upper and lower limit masks to the power vector. If the limit mask is defined as the relative power to the reference power, the algorithm calculates the average power of the reference region and draws the limit mask using the reference power. If the limit mask is defined as the absolute power, the algorithm draws the limit mask using the absolute power settings.

The limit mask is highly configurable to allow various types of limit mask.

After the mask position is determined, the algorithm verifies if the signal’s power vector is within the limit mask. If it satisfies the limit for the entire capture length, the instrument reports “PASS”. If the signal’s power vector exceeds the limit mask at a single sample point, the measurement reports “FAIL” and conveys information about where the signal exceeds the test limit.

Upon averaging, the measurement calculates the ensemble average of power vectors from multiple acquisitions. The burst position in the acquired data, however, can be different from acquisition to acquisition. This is called “burst wobbling”. Therefore, simply calculating the ensemble average over power vectors can yield meaningless result. This is especially true if Free Run trigger is used for the acquisition.

To avoid this problem, the algorithm uses averaging that ensures that the reference point of the burst comes to the exact same timing. This is called the anti-wobbling function. It yields a meaningful average and also stabilizes the displayed trace as the averaging continues.

In the process of burst detection, the timing of a burst is obtained. The time period from trigger to the

reference position of the burst is called “T0”. This measurement returns the T0 result value as well. The burst detection algorithm always searches a burst from the beginning of the capture data and picks up the first one that satisfies the burst detection parameters. For example, if there are two valid bursts in the captured data, the second one will be ignored.

For applications such as the WiMAX-OFDMA uplink measurement, the captured TDD (Time Division Duplex) signal can contain both downlink and uplink bursts. In this case, a customer must use external trigger and set an appropriate trigger delay so that the uplink or downlink burst comes to the beginning of the captured data selectively.

Spectrum Emission Mask Measurement Concepts

Purpose

This measurement measures the spectral profile of the transmitter to verify that the device is not transmitting excessive energy outside its assigned channel bandwidth. Most WiMAX deployments will be in frequency bands that are controlled by local regulations. Because these regulations vary widely, the 802.16 specification does not attempt to specify spectral mask for any operation, other than as “unlicensed”. The measurement procedure defined here is the same, however specific limits must be determined by the user and will depend on where the device will be deployed. Figure 6-35 shows the spectral mask specification for 802.16 “unlicensed” operations.

Figure 6-35 Spectral Mask for 802.16 Unlicensed Operation

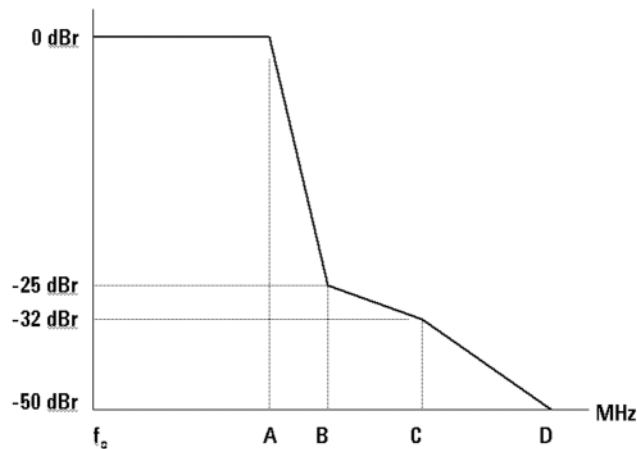

| Channelization (MHz) | A | B | C | D |
|----------------------|------|------|------|-------|
| 20 | 9.5 | 10.9 | 19.5 | 29.5 |
| 10 | 4.75 | 5.45 | 9.75 | 14.75 |

The Spectrum Emission Mask measurement includes the in-band and out-of-band spurious emissions. This is the power contained in a specified frequency bandwidth at certain offsets relative to the total carrier power. It may also be expressed as a ratio of power spectral densities between the carrier and the specified offset frequency band.

This spectrum emission mask measurement is a composite measurement of out-of-channel emissions,

combining both in-band and out-of-band specifications. It provides useful figures-of-merit for the spectral regrowth and emissions produced by components and circuit blocks, without the rigor of performing a full spectrum emissions mask measurement.

Measurement Method

The spectrum emission mask measurement measures spurious signal levels in up to five pairs of offset/region frequencies and relates them to the carrier power. The reference channel integration bandwidth method is used to measure the carrier channel power and offset/region powers. When **Offset** is selected, spectrum emission mask measurements are made, relative to the carrier channel frequency bandwidth. When **Region** is selected, spurious emission absolute measurements are made, set by specifying start and stop RF frequencies. The upper frequency range limit is 3.678 GHz.

This integration bandwidth method is used to perform a data acquisition. In this process, the reference channel integration bandwidth (Meas BW) is analyzed using the automatically defined resolution bandwidth (Res BW), which is much narrower than the channel bandwidth. The measurement computes an average power of the channel or offset/region over a specified number of data acquisitions, automatically compensating for resolution bandwidth and noise bandwidth.

This measurement requires the user to specify the measurement bandwidths of carrier channel and each of the offset/region frequency pairs up to 5. Each pair may be defined with unique measurement bandwidths. The results are displayed both as relative power in dBc, and as absolute power in dBm.

Spurious Emissions Measurement Concepts

Purpose

A typical RF output section uses filtering devices to suppress unwanted “internal” signals from being transmitted. The internal signals are unwanted by-products of the normal signal creation process (such as mixing, modulation, or amplification). These are typically classified as either harmonics or spurious signals. Harmonics are integer multiples of the primary transmitter frequency and therefore the frequency at which they will appear is very predictable. Spurious signals are typically image frequencies caused by internal mixing of an oscillator or clock frequency with the primary transmitter output frequency.

Understanding the block diagram of a device is helpful to understand potential sources of spurious energy; however, it is still common to use “spur searches” to scan the entire output spectrum of the device to look for spurious energy. Signal analyzers with spectrum analysis capability are ideal instruments to be used to identify both harmonic and spurious measurements. Typically harmonics are measured to at least the 5th harmonic - implying for a 3.5 GHz signal, for example, a spectrum analyzer that extends to 17.5 GHz is required.

Measurement Method

This measurement uses the Peak Excursion and Peak Threshold values to determine which spurs to report. For each range that is specified, the analyzer scans the band using the specified Range Table settings. As each band is swept, any signal that is above the Peak Threshold value and has a peak excursion that exceeds the Peak Excursion value will be entered on a list of spurs which is displayed in the lower results window in the display.

A total of 200 spurs can be recorded for one measurement, with a limit of 10 spurs per frequency range. From the spurs in the list, each of those with a peak amplitude greater than the Absolute Limit for that

range will be logged as a measurement failure and denoted by a red 'F' in the 'Amplitude' column of the table.

If no spurs are reported, but the measured trace exceeds the limit line for any range, the fail flag is set to fail.

This measurement has the ability to display two traces using different detectors on the display simultaneously. All spur detection and limit line testing are only applied to the trace associated with Detector 1.

Baseband I/Q Inputs (Option BBA) Measurement Concepts

The N9020A Option BBA Baseband I/Q Inputs provides the ability to analyze baseband I/Q signal characteristics of mobile and base station transmitters. This option may be used only in conjunction with the following modes:

- IQ Analyzer (Basic)
- 802.16 OFDMA (WiMAX/WiBro)
- cdma2000
- GSM/EDGE
- TD-SCDMA
- W-CDMA
- 1xEV-DO
- LTE
- LTE TDD
- DTMB
- DVB-T/H
- ISDB-T
- CMMB

What are Baseband I/Q Inputs?

Option BBA consists of a Baseband Input module, four input connectors, and a calibration output connector. The connectors are at the left side of the front panel. The two ports labeled “I” and “Q” are the “unbalanced” inputs.

An unbalanced or “single-ended” baseband measurement of an I or Q signal is made using a probe connected to the I or Q connector. A simultaneous I/Q unbalanced single-ended measurement may be made using two probes connected to the I and Q input connectors.

If “balanced” signals are available, they may be used to make a more accurate measurement. Balanced signals are signals present in two separate conductors, are symmetrical about ground, and are opposite in polarity, or out of phase by 180 degrees.

Measurements using balanced signals can have a higher signal to noise ratio resulting in improved accuracy. Noise coupled into each conductor equally in a “common mode” to both signals may be separated from the signal. The measure of this separation is “common-mode rejection”.

To make a balanced measurement, the two connectors labeled “I” and “Q” are used in conjunction with the I and Q inputs. The terms “I-bar” and “Q-bar” may be applied to the signals, as well as the inputs themselves. Probes (customer provided) must be used to input balanced baseband I/Q signals. This may be referred to as a balanced measurement.

Balanced baseband measurements are made using the I and connectors for I only signal measurements, while the Q and connectors are used for a Q only signal measurement. Balanced measurements of I/Q require differential probe connections to all four input connectors. For details of probe selection and use, refer to “[Selecting Input Probes for Baseband Measurements](#)” on page 160.

What are Baseband I/Q Signals?

In transmitters, the term baseband I/Q refers to signals that are the fundamental products of individual I/Q modulators, before the I and Q component signals are combined, and before upconversion to IF or RF frequencies.

In receivers, baseband I/Q analysis may be used to test the I and Q products of I/Q demodulators, after an RF signal has been downconverted and demodulated.

Why Make Measurements at Baseband?

Baseband I/Q measurements are a valuable means of making qualitative analyses of the following operating characteristics:

- I/Q signal layer access for performing format-specific demodulation measurements (for example, CDMA, GSM, W-CDMA).
- Modulation accuracy – that is, I/Q plane metrics:
 - rho
 - error vector magnitude; rms, peak, or 95%
 - carrier feed-through
 - frequency error
 - magnitude and phase errors
- Code-domain analysis (including code-specific metrics)
- CCDF of $I^2 + Q^2$
- Single sideband (SSB) metrics for assessing output quality
- Basic analysis of I and Q signals in isolation including: DC content, rms and peak to peak levels, CCDF of each channel

Comparisons of measurements made at baseband and RF frequencies produced by the same device are especially revealing. Once signal integrity is verified at baseband, impairments can be traced to specific stages of upconversion, amplification, or filtering by RF analysis. In addition, impairments to signal quality that are apparent at RF frequencies may be traceable to baseband using baseband analysis.

Selecting Input Probes for Baseband Measurements

The selection of baseband measurement probe(s) and measurement method is primarily dependent on the location of the measurement point in the circuit. The probe must sample voltages without imposing an inappropriate load on the circuit.

The system supports a variety of 1 M Ω impedance input passive probes as well as the Agilent 1153A active differential probe using the InfiniMax probe interface.

The Agilent 1153A active probe can be used for both single-ended and differential measurements. In either case a single connection is made for each channel (on either the I or Q input). The input is automatically configured to 50 Ω single-ended type measurement and the probe power is supplied through the InfiniMax interface. The probe can be configured for a variety of input coupling and low frequency rejection modes. In addition, a wide range of offset voltages and probe attenuation accessories are supported at the probe interface. The active probe has the advantage that it does not significantly load the circuit under test, even with unity gain probing.

With passive 1 M Ω probes, the probe will introduce a capacitive load on the circuit, unless a higher attenuation is used at the probe interface. Higher attenuation helps isolate the probe, however, it reduces the signal level and degrades the signal-to-noise-ratio of the measurement. Passive probes are available with a variety of attenuation values for a moderate cost. Many Agilent passive probes can be automatically identified by the system, setting the input impedance required as well as the nominal attenuation. For single-ended measurements a single probe is used for each channel. Other passive probes can be used, after manually setting the attenuation and probe impedance configurations.

For full differential measurements, the system supports probes on each of the four inputs. The attenuation for each of the probes should be the same for good common mode rejection and channel match.

Supported Probes

The following table lists the probes currently supported by Option BBA:

Table 6-8

| Probe Type | Model Number | Description |
|------------|--------------------|--|
| Active | 1130A | 1.5 GHz differential probe amp (No probe head) |
| | 1131A ^a | InfiniMax 3.5 GHz probe |
| | 1132A ^a | InfiniMax 5 GHz probe |
| | 1133A ^a | InfiniMax 7 GHz probe |
| Passive | 1161A | Miniature passive probe, 10:1, 10 M Ω , 1.5 m |

- a. Probe heads are necessary to attach to your device properly. Probe connectivity kits such as the E2668A, E2669A or E2675A are needed. For more details, refer to the Agilent probe configuration guide, 5968-7141EN and 5989-6162EN.

Probes without Stored Calibration

The following 115xA active probes may be used with the MXA's baseband IQ inputs and may use the same probe calibration utility software. However, the probe calibration data is not stored in the MXA and will be lost if power is cycled. Use of the E2655B de-skew and calibration kit, including the calibration fixture, is required because of the different physical configuration of the probes. (The physical connections are different mechanically, not electrically.)

Table 6-9

| Probe Type | Model Number | Description |
|------------|--------------|---------------------------|
| Active | 1153A | 200MHz differential probe |
| | 1156A | Active probe, 1.5 GHz |
| | 1157A | Active probe, 2.5 GHz |
| | 1158A | Active probe, 4 GHz |

Refer to the current Agilent probe data sheet for specific information regarding frequency of operation and power supply requirements.

Baseband I/Q Measurement Views

Measurement result views made in the IQ Analyzer (Basic) mode are available for baseband signals if they relate to the nature of the signal itself. Many measurements which relate to the characteristics that baseband I and Q signals have when mixed and upconverted to signals in the RF spectrum can be made as well. However, measurements which relate to the characteristics of an upconverted signal that lie beyond the bandwidth available to the Baseband I/Q Input circuits can not be measured (the limit are dependent on the installed options: Standard – 10 Hz to 20 MHz, Option B25 – 10 Hz to 50 MHz, and Option S40 – 10 Hz to 80 MHz).

At RF frequencies, power measurements are conventionally displayed on a logarithmic vertical scale in dBm units, whereas measurements of baseband signals using Baseband I/Q inputs may be conveniently displayed as voltage using a linear vertical scale as well as a log scale.

Spectrum Views and 0 Hz Center Frequency

To view the Spectrum display of I only or Q only signals, use the Complex Spectrum measurement capability in IQ Analyzer (Basic) Mode.

I only and Q only Spectrum views are conventional, displayed with 0 Hz at the left side of the horizontal axis. When upconverted or multiplied, an I only or Q only signal could ultimately lie above or below the carrier center frequency, but in either case it will only occupy half the bandwidth.

Waveform Views for Baseband I/Q Inputs

For Waveform measurements, two displays are available for baseband I/Q input signals; the I and Q Waveform view, which separates the individual I and Q traces, and the RF Envelope view.

Waveform Signal Envelope Views of I only or Q only

To view the Signal Envelope display of I only or Q only signals, use the Waveform measurement

capability in IQ Analyzer (Basic) Mode.

The I and Q Waveform of an I/Q signal is very different from the complex signal displayed in the RF Envelope view. That is because the RF Envelope is a product of both the I and Q modulation waveforms.

However, an I and Q Waveform measurement of an I only or Q only signal is exactly the same signal displayed in the RF Envelope view. That is because an I only or Q only waveform determines the I only or Q only signal envelope. Thus, the RF Envelope view can be used to measure an I only or Q only waveform directly.

Other Sources of Measurement Information

Additional measurement application information is available through your local Agilent Technologies sales and service office. The following application notes treat digital communications measurements in much greater detail than discussed in this section.

- Application Note 1298
Digital Modulation in Communications Systems - An Introduction
Agilent part number 5965-7160E
- Application Note
Characterizing Digitally Modulated Signals with CCDF Curves
Agilent part number 5968-5858E
- Application Note
HSDPA RF Measurements for User Equipment
Agilent part number 5989-4099EN

Instrument Updates at www.agilent.com

These web locations can be used to access the latest information about the instrument, including the latest firmware version.

<http://www.agilent.com/find/pxa>
<http://www.agilent.com/find/mxa>
<http://www.agilent.com/find/exa>
<http://www.agilent.com/find/cxa>

Appendix A

Agilent WiMAX Frequency and Time Parameter Table

The WiMAX frequency and time parameter table provides signal information useful for evaluating and troubleshooting the physical layer of IEEE 802.16-2005 OFDMA signals. Most of these parameters are directly measurable by an analyzer with vector analysis capabilities or a high performance spectrum analyzer in zero span. To successfully demodulate a WiMAX signal, most analyzers require the following minimum parameter settings: center frequency, nominal bandwidth, sampling factor, and guard interval.

Following are explanations for some terms used on the parameter table:

Nominal bandwidth: A descriptive term for the bandwidth of the WiMAX signal; it is not the actual bandwidth of the signal.

200 carrier bandwidth: The actual bandwidth of the WiMAX signal. If you examine the frequency and time parameter table, you will see that a 5 MHz nominal bandwidth signal should have a 200 carrier (actual) bandwidth of 4.5 MHz. Measuring this parameter also provides an indirect measure of the sampling factor.

Carrier spacing: The correct spacing between each carrier in the WiMAX signal. Measuring the carrier spacing provides an indirect measure of the symbol time.

Guard interval: Three different guard intervals are allowed for each nominal bandwidth.

OFDMA symbol time: The sum of the symbol time and a guard interval. Longer OFDMA symbol times are generally more immune to multi-path interference. Shorter symbol times have higher data bandwidths.

Long preamble: Measuring the duration of the long preamble provides an indirect measure of the OFDMA symbol time. Subtract Symbol time from the OFDMA symbol time to find the guard interval.

Figure 6-36 Agilent WiMAX Frequency and Time Parameter Table

| Nominal BW | Sampling factor (Fs/BW) | 256 carrier BW (Fs) | 200 carrier BW (Fs x 200/256) | Carrier spacing DF = Fs/256 | Symbol time Tb = 1/DF | Guard interval G | Guard interval time Tg = G x Tb | OFDM symbol time Ts = Tb + Tg | Long preamble (DL = 2 x Ts) | Short preamble (UL = Ts) |
|------------|-------------------------|---------------------|-------------------------------|-----------------------------|-----------------------|------------------|---------------------------------|-------------------------------|-----------------------------|--------------------------|
| MHz | | MHz | MHz | kHz | µSec | | µSec | µSec | µSec | µSec |
| 28.00 | 8/7 | 32.00 | 25.00 | 125.00 | 8.00 | 1/4 | 2.00 | 10.00 | 20.00 | 10.00 |
| | | | | | | 1/8 | 1.00 | 9.00 | 18.00 | 9.00 |
| | | | | | | 1/16 | 0.50 | 8.50 | 17.00 | 8.50 |
| | | | | | | 1/32 | 0.25 | 8.25 | 16.50 | 8.25 |
| 24.00 | 86/75 | 27.52 | 21.50 | 107.50 | 9.30 | 1/4 | 2.33 | 11.63 | 23.26 | 11.63 |
| | | | | | | 1/8 | 1.16 | 10.47 | 20.93 | 10.47 |
| | | | | | | 1/16 | 0.58 | 9.88 | 19.77 | 9.88 |
| | | | | | | 1/32 | 0.29 | 9.59 | 19.19 | 9.59 |
| 20.00 | 144/125 | 23.04 | 18.00 | 90.00 | 11.11 | 1/4 | 2.78 | 13.89 | 27.78 | 13.89 |
| | | | | | | 1/8 | 1.39 | 12.50 | 25.00 | 12.50 |
| | | | | | | 1/16 | 0.69 | 11.81 | 23.61 | 11.81 |
| | | | | | | 1/32 | 0.35 | 11.46 | 22.92 | 11.46 |
| 15.00 | 86/75 | 17.20 | 13.44 | 67.19 | 14.88 | 1/4 | 3.72 | 18.60 | 37.21 | 18.60 |
| | | | | | | 1/8 | 1.86 | 16.74 | 33.49 | 16.74 |
| | | | | | | 1/16 | 0.93 | 15.81 | 31.63 | 15.81 |
| | | | | | | 1/32 | 0.47 | 15.35 | 30.70 | 15.35 |
| 14.00 | 8/7 | 16.00 | 12.50 | 62.50 | 16.00 | 1/4 | 4.00 | 20.00 | 40.00 | 20.00 |
| | | | | | | 1/8 | 2.00 | 18.00 | 36.00 | 18.00 |
| | | | | | | 1/16 | 1.00 | 17.00 | 34.00 | 17.00 |
| | | | | | | 1/32 | 0.50 | 16.50 | 33.00 | 16.50 |
| 12.00 | 86/75 | 13.76 | 10.75 | 53.75 | 18.60 | 1/4 | 4.65 | 23.26 | 46.51 | 23.26 |
| | | | | | | 1/8 | 2.33 | 20.93 | 41.86 | 20.93 |
| | | | | | | 1/16 | 1.16 | 19.77 | 39.53 | 19.77 |
| | | | | | | 1/32 | 0.58 | 19.19 | 38.37 | 19.19 |
| 11.00 | 316/275 | 12.64 | 9.88 | 49.38 | 20.25 | 1/4 | 5.06 | 25.32 | 50.63 | 25.32 |
| | | | | | | 1/8 | 2.53 | 22.78 | 45.57 | 22.78 |
| | | | | | | 1/16 | 1.27 | 21.52 | 43.04 | 21.52 |
| | | | | | | 1/32 | 0.63 | 20.89 | 41.77 | 20.89 |
| 10.00 | 144/125 | 11.52 | 9.00 | 45.00 | 22.22 | 1/4 | 5.56 | 27.78 | 55.56 | 27.78 |
| | | | | | | 1/8 | 2.78 | 25.00 | 50.00 | 25.00 |
| | | | | | | 1/16 | 1.39 | 23.61 | 47.22 | 23.61 |
| | | | | | | 1/32 | 0.69 | 22.92 | 45.83 | 22.92 |
| 7.00 | 8/7 | 8.00 | 6.25 | 31.25 | 32.00 | 1/4 | 8.00 | 40.00 | 80.00 | 40.00 |
| | | | | | | 1/8 | 4.00 | 36.00 | 72.00 | 36.00 |
| | | | | | | 1/16 | 2.00 | 34.00 | 68.00 | 34.00 |
| | | | | | | 1/32 | 1.00 | 33.00 | 66.00 | 33.00 |
| 6.00 | 86/75 | 6.88 | 5.38 | 26.88 | 37.21 | 1/4 | 9.30 | 46.51 | 93.02 | 46.51 |
| | | | | | | 1/8 | 4.65 | 41.86 | 83.72 | 41.86 |
| | | | | | | 1/16 | 2.33 | 39.53 | 79.07 | 39.53 |
| | | | | | | 1/32 | 1.16 | 38.37 | 76.74 | 38.37 |
| 5.50 | 316/275 | 6.32 | 4.94 | 24.69 | 40.51 | 1/4 | 10.13 | 50.63 | 101.27 | 50.63 |
| | | | | | | 1/8 | 5.06 | 45.57 | 91.14 | 45.57 |
| | | | | | | 1/16 | 2.53 | 43.04 | 86.08 | 43.04 |
| | | | | | | 1/32 | 1.27 | 41.77 | 83.54 | 41.77 |
| 5.00 | 144/125 | 5.76 | 4.50 | 22.50 | 44.44 | 1/4 | 11.11 | 55.56 | 111.11 | 55.56 |
| | | | | | | 1/8 | 5.56 | 50.00 | 100.00 | 50.00 |
| | | | | | | 1/16 | 2.78 | 47.22 | 94.44 | 47.22 |
| | | | | | | 1/32 | 1.39 | 45.83 | 91.67 | 45.83 |
| 3.50 | 8/7 | 4.00 | 3.13 | 15.63 | 64.00 | 1/4 | 16.00 | 80.00 | 160.00 | 80.00 |
| | | | | | | 1/8 | 8.00 | 72.00 | 144.00 | 72.00 |
| | | | | | | 1/16 | 4.00 | 68.00 | 136.00 | 68.00 |
| | | | | | | 1/32 | 2.00 | 66.00 | 132.00 | 66.00 |
| 3.00 | 86/75 | 3.44 | 2.69 | 13.44 | 74.42 | 1/4 | 18.60 | 93.02 | 186.05 | 93.02 |
| | | | | | | 1/8 | 9.30 | 83.72 | 167.44 | 83.72 |
| | | | | | | 1/16 | 4.65 | 79.07 | 158.14 | 79.07 |
| | | | | | | 1/32 | 2.33 | 76.74 | 153.49 | 76.74 |

Figure 6-37 Agilent WiMAX Frequency and Time Parameter Table (2)

| Nominal BW | Sampling factor (Fs/BW) | 256 carrier BW (Fs) | 200 carrier BW (Fs x 200/256) | Carrier spacing DF = Fs/256 | Symbol time Tb = 1/DF | Guard interval G | Guard interval time Tg = G x Tb | OFDM symbol time Ts = Tb + Tg | Long preamble (DL = 2 x Ts) | Short preamble (UL = Ts) |
|------------|-------------------------|---------------------|-------------------------------|-----------------------------|-----------------------|------------------|---------------------------------|-------------------------------|-----------------------------|--------------------------|
| MHz | | MHz | MHz | kHz | µSec | | µSec | µSec | µSec | µSec |
| 2.50 | 144/125 | 2.88 | 2.25 | 11.25 | 88.89 | 1/4 | 22.22 | 111.11 | 222.22 | 111.11 |
| | | | | | | 1/8 | 11.11 | 100.00 | 200.00 | 100.00 |
| | | | | | | 1/16 | 5.56 | 94.44 | 188.89 | 94.44 |
| | | | | | | 1/32 | 2.78 | 91.67 | 183.33 | 91.67 |
| 1.75 | 8/7 | 2.00 | 1.56 | 7.81 | 128.00 | 1/4 | 32.00 | 160.00 | 320.00 | 160.00 |
| | | | | | | 1/8 | 16.00 | 144.00 | 288.00 | 144.00 |
| | | | | | | 1/16 | 8.00 | 136.00 | 272.00 | 136.00 |
| | | | | | | 1/32 | 4.00 | 132.00 | 264.00 | 132.00 |
| 1.50 | 86/75 | 37.21 | 186.05 | 372.09 | 186.05 | 1/4 | 37.21 | 186.05 | 372.09 | 186.05 |
| | | | | | | 1/8 | 18.60 | 167.44 | 334.88 | 167.44 |
| | | | | | | 1/16 | 9.30 | 158.14 | 316.28 | 158.14 |
| | | | | | | 1/32 | 4.65 | 153.49 | 306.98 | 153.49 |
| 1.25 | 144/125 | 44.44 | 222.22 | 444.44 | 222.22 | 1/4 | 44.44 | 222.22 | 444.44 | 222.22 |
| | | | | | | 1/8 | 22.22 | 200.00 | 400.00 | 200.00 |
| | | | | | | 1/16 | 11.11 | 188.89 | 377.78 | 188.89 |
| | | | | | | 1/32 | 5.56 | 183.33 | 366.67 | 183.33 |

Appendix B

WiMAX Standard Selection Preset Values

Figure 6-38 Mode Setup Preset Values Table

Standard selection preset values

The following parameters are preset when the standard selection is made.

When 802.16 OFDMA 28MHz is selected, measurement that uses IQ acquisition such as Modulation Analysis, CCDF, Power vs Time will be grayed out.

Please note that the values provided in the following tables may be changed in the future.

Mode Setup

| Standard | FFT size | BW Ratio | Guard Interval | Frame Duration | Downlink Ratio |
|----------------------|----------|----------|----------------|----------------|----------------|
| 802.16 OFDMA 1.25MHz | 128 | 28/25 | 1/8 | 5 ms | 50.0 % |
| 802.16 OFDMA 3.5MHz | 512 | 8/7 | 1/8 | 5 ms | 50.0 % |
| 802.16 OFDMA 5MHz | 512 | 28/25 | 1/8 | 5 ms | 50.0 % |
| 802.16 OFDMA 7MHz | 1024 | 8/7 | 1/8 | 4 ms | 50.0 % |
| 802.16 OFDMA 8.75MHz | 1024 | 8/7 | 1/8 | 5 ms | 50.0 % |
| 802.16 OFDMA 10MHz | 1024 | 28/25 | 1/8 | 5 ms | 50.0 % |
| 802.16 OFDMA 14MHz | 1024 | 8/7 | 1/8 | 4 ms | 50.0 % |
| 802.16 OFDMA 15MHz | 1024 | 28/25 | 1/8 | 5 ms | 50.0 % |
| 802.16 OFDMA 17.5MHz | 2048 | 8/7 | 1/8 | 5 ms | 50.0 % |
| 802.16 OFDMA 20MHz | 2048 | 28/25 | 1/8 | 5 ms | 50.0 % |
| 802.16 OFDMA 28MHz | 2048 | 8/7 | 1/8 | 4 ms | 50.0 % |
| WiBro 4.375MHz | 512 | 8/7 | 1/8 | 5 ms | 63.952 % |
| WiBro 8.75MHz | 1024 | 8/7 | 1/8 | 5 ms | 63.952 % |
| WiBro 17.5MHz | 2048 | 8/7 | 1/8 | 5 ms | 63.952 % |

Figure 6-39 Channel Power and Occupied Bandwidth Standard Preset Values Table

Channel Power, Occupied Bandwidth

| Standard | RBW | VBW | Span | IBW (CHP only) |
|----------------------|--------|--------|---------|----------------|
| 802.16 OFDMA 1.25MHz | 24kHz | 240kHz | 2.5MHz | 1.25MHz |
| 802.16 OFDMA 3.5MHz | 68kHz | 680kHz | 7MHz | 3.5MHz |
| 802.16 OFDMA 5MHz | 91kHz | 910kHz | 10MHz | 5MHz |
| 802.16 OFDMA 7MHz | 130kHz | 1.3MHz | 14MHz | 7MHz |
| 802.16 OFDMA 8.75MHz | 160kHz | 1.6MHz | 17.5MHz | 8.75MHz |
| 802.16 OFDMA 10MHz | 180kHz | 1.8MHz | 20MHz | 10MHz |
| 802.16 OFDMA 14MHz | 270kHz | 2.7MHz | 28MHz | 14MHz |
| 802.16 OFDMA 15MHz | 270kHz | 2.7MHz | 30MHz | 15MHz |
| 802.16 OFDMA 17.5MHz | 330kHz | 3MHz | 35MHz | 17.5MHz |
| 802.16 OFDMA 20MHz | 390kHz | 4MHz | 40MHz | 20MHz |
| 802.16 OFDMA 28MHz | 510kHz | 5MHz | 56MHz | 28MHz |
| WiBro 4.375MHz | 82kHz | 820kHz | 8.75MHz | 4.375MHz |
| WiBro 8.75MHz | 160kHz | 1.6MHz | 17.5MHz | 8.75MHz |
| WiBro 17.5MHz | 330kHz | 3MHz | 35MHz | 17.5MHz |

Figure 6-40 **CCDF Presets Value Tables**

CCDF

| Standard | Info BW | Note |
|----------------------|---------|--------------|
| 802.16 OFDMA 1.25MHz | 2MHz | |
| 802.16 OFDMA 3.5MHz | 5MHz | |
| 802.16 OFDMA 5MHz | 6MHz | |
| 802.16 OFDMA 7MHz | 10MHz | |
| 802.16 OFDMA 8.75MHz | 10MHz | |
| 802.16 OFDMA 10MHz | 10MHz | |
| 802.16 OFDMA 14MHz | 25MHz | Need B25 opt |
| 802.16 OFDMA 15MHz | 25MHz | |
| 802.16 OFDMA 17.5MHz | 25MHz | Need B25 opt |
| 802.16 OFDMA 20MHz | 25MHz | Need B25 opt |
| 802.16 OFDMA 28MHz | --- | Not availale |
| WiBro 4.375MHz | 6MHz | |
| WiBro 8.75MHz | 25MHz | Need B25 opt |
| WiBro 17.5MHz | 25MHz | Need B25 opt |

Figure 6-41 Spectrum Emissions Mask Standard Presets Value Tables (1)

Spectrum Emission Mask

| Standard | Span | R | Start Freq | Stop Freq | Res BW | Rel Start | Rel Stop | Fail | Meas BW |
|-------------------------|----------|---|------------|-----------|--------|-----------|----------|------|---------|
| 802.16 OFDMA 1.25MHz | 3.68MHz | A | 0 | 0.59M | 100K | 0 | 0 | Rel | 1 |
| | | B | 0.59M | 0.68M | 100K | 0 | -25 | Rel | 1 |
| | | C | 0.68M | 1.22M | 100K | -25 | -32 | Rel | 1 |
| | | D | 1.22M | 1.84M | 100K | -32 | -50 | Rel | 1 |
| 802.16 OFDMA 3.5MHz | 10.32MHz | A | 0 | 1.66M | 100K | 0 | 0 | Rel | 1 |
| | | B | 1.66M | 1.91M | 100K | 0 | -25 | Rel | 1 |
| | | C | 1.91M | 3.41M | 100K | -25 | -32 | Rel | 1 |
| | | D | 3.41M | 5.16M | 100K | -32 | -50 | Rel | 1 |
| 802.16 OFDMA 5MHz | 14.76MHz | A | 0 | 2.38M | 100K | 0 | 0 | Rel | 1 |
| | | B | 2.38M | 2.73M | 100K | 0 | -25 | Rel | 1 |
| | | C | 2.73M | 4.88M | 100K | -25 | -32 | Rel | 1 |
| | | D | 4.88M | 7.38M | 100K | -32 | -50 | Rel | 1 |
| 802.16 OFDMA 7MHz | 20.66MHz | A | 0 | 3.33M | 100K | 0 | 0 | Rel | 1 |
| | | B | 3.33M | 3.82M | 100K | 0 | -25 | Rel | 1 |
| | | C | 3.82M | 6.82M | 100K | -25 | -32 | Rel | 1 |
| | | D | 6.82M | 10.33M | 100K | -32 | -50 | Rel | 1 |
| 802.16 OFDMA 8.75MHz | 25.82MHz | A | 0 | 4.16M | 100K | 0 | 0 | Rel | 1 |
| | | B | 4.15M | 4.77M | 100K | 0 | -25 | Rel | 1 |
| | | C | 4.77M | 8.53M | 100K | -25 | -32 | Rel | 1 |
| | | D | 8.53M | 12.91M | 100K | -32 | -50 | Rel | 1 |
| 802.16 OFDMA 10MHz | 29.5MHz | A | 0 | 4.75M | 100K | 0 | 0 | Rel | 1 |
| | | B | 4.75M | 5.45M | 100K | 0 | -25 | Rel | 1 |
| | | C | 5.45M | 9.75M | 100K | -25 | -32 | Rel | 1 |
| | | D | 9.75M | 14.75M | 100K | -32 | -50 | Rel | 1 |
| 802.16 OFDMA 14MHz | 41.3MHz | A | 0 | 6.65M | 100K | 0 | 0 | Rel | 1 |
| | | B | 6.65M | 7.63M | 100K | 0 | -25 | Rel | 1 |
| | | C | 7.63M | 13.65M | 100K | -25 | -32 | Rel | 1 |
| | | D | 13.65M | 20.65M | 100K | -32 | -50 | Rel | 1 |

Figure 6-42 Spectrum Emissions Mask Standard Presets Value Table

Spectrum Emission Mask - 2

| Standard | Span | R | Start Freq | Stop Freq | Res BW | Rel Start | Rel Stop | Fail | Meas BW |
|-------------------------|----------|---|------------|-----------|--------|-----------|----------|------|---------|
| 802.16 OFDMA 15MHz | 44.26MHz | A | 0 | 7.13M | 100K | 0 | 0 | Rel | 1 |
| | | B | 7.13M | 8.18M | 100K | 0 | -25 | Rel | 1 |
| | | C | 8.18M | 14.63M | 100K | -25 | -32 | Rel | 1 |
| | | D | 14.63M | 22.13M | 100K | -32 | -50 | Rel | 1 |
| 802.16 OFDMA 17.5MHz | 51.62MHz | A | 0 | 8.31M | 100K | 0 | 0 | Rel | 1 |
| | | B | 8.31M | 9.54M | 100K | 0 | -25 | Rel | 1 |
| | | C | 9.54M | 17.06M | 100K | -25 | -32 | Rel | 1 |
| | | D | 17.06M | 25.81M | 100K | -32 | -50 | Rel | 1 |
| 802.16 OFDMA 20MHz | 59MHz | A | 0M | 9.5M | 100K | 0 | 0 | Rel | 1 |
| | | B | 9.5M | 10.9M | 100K | 0 | -25 | Rel | 1 |
| | | C | 10.9M | 19.5M | 100K | -25 | -32 | Rel | 1 |
| | | D | 19.5M | 29.5M | 100K | -32 | -50 | Rel | 1 |
| 802.16 OFDMA 28MHz | 82.6MHz | A | 0M | 13.3M | 100K | 0 | 0 | Rel | 1 |
| | | B | 13.3M | 15.26M | 100K | 0 | -25 | Rel | 1 |
| | | C | 15.26M | 27.3M | 100K | -25 | -32 | Rel | 1 |
| | | D | 27.3M | 41.3M | 100K | -32 | -50 | Rel | 1 |
| WiBro 4.375MHz | 12.9MHz | A | 0 | 2.08M | 100K | 0 | 0 | Rel | 1 |
| | | B | 2.08M | 2.38M | 100K | 0 | -25 | Rel | 1 |
| | | C | 2.38M | 4.27M | 100K | -25 | -32 | Rel | 1 |
| | | D | 4.27M | 6.45M | 100K | -32 | -50 | Rel | 1 |
| WiBro 8.75MHz | 25.82MHz | A | 0 | 4.16M | 100K | 0 | 0 | Rel | 1 |
| | | B | 4.15M | 4.77M | 100K | 0 | -25 | Rel | 1 |
| | | C | 4.77M | 8.53M | 100K | -25 | -32 | Rel | 1 |
| | | D | 8.53M | 12.91M | 100K | -32 | -50 | Rel | 1 |
| WiBro 17.5MHz | 51.62MHz | A | 0 | 8.31M | 100K | 0 | 0 | Rel | 1 |
| | | B | 8.31M | 9.54M | 100K | 0 | -25 | Rel | 1 |
| | | C | 9.54M | 17.06M | 100K | -25 | -32 | Rel | 1 |
| | | D | 17.06M | 25.81M | 100K | -32 | -50 | Rel | 1 |

Figure 6-43 Power vs. Time Standard Preset Values Table

Power vs Time

| Standard | Region | On/Off | Info BW | Start Time | Stop Time | Upper | | | | | | Lower | | | | | | | |
|----------------------|--------|--------|---------|------------|-----------|-------|------|------------|-------|------|------------|-----------|-------|------|------------|-------|------|------------|-----------|
| | | | | | | Abs | | | Rel | | | Fail Mask | Abs | | | Rel | | | Fail Mask |
| | | | | | | Start | Stop | Aut o/M an | Start | Stop | Aut o/M an | | Start | Stop | Aut o/M an | Start | Stop | Aut o/M an | |
| | | | | | | dB m | dB m | | dB | dB | | dB m | dB m | | dB | dB | | | |
| 802.16 OFDMA 1.25MHz | A | On | 2M Hz | -1.0 | -50e-6 | 0 | 0 | A | -25 | 0 | A | REL | -200 | 0 | A | 0 | 0 | A | ABS |
| | B | On | | -50e-6 | 0 | 0 | 0 | A | 16 | 0 | A | REL | -200 | 0 | A | 0 | 0 | A | ABS |
| | C | On | | 0 | 50e-6 | 0 | 0 | A | 16 | 0 | A | REL | -200 | 0 | A | 0 | 0 | A | ABS |
| | D | On | | 50e-6 | 50e-6 | 0 | 0 | A | 16 | 0 | A | REL | -200 | 0 | A | 0 | 0 | A | ABS |
| | E | On | | 500e-6 | 2.5e-3 | 0 | 0 | A | 7 | 0 | A | REL | -200 | 0 | A | 0 | 0 | A | ABS |
| | F | Off | | 2.5e-3 | 4.8e-3 | 0 | 0 | A | -25 | 0 | A | REL | -200 | 0 | A | 0 | 0 | A | ABS |
| | G | On | | 4.8e-3 | 1.0 | 200 | 0 | A | 200 | 0 | A | ABS | -200 | 0 | A | 0 | 0 | A | ABS |
| | H to L | Off | | 0 | 0 | 0 | 0 | A | 0 | 0 | A | REL | 0 | 0 | A | 0 | 0 | A | REL |
| 802.16 OFDMA 3.5MHz | A | On | 5M Hz | -1.0 | -50e-6 | 0 | 0 | A | -25 | 0 | A | REL | -200 | 0 | A | 0 | 0 | A | ABS |
| | B | On | | -50e-6 | 0 | 0 | 0 | A | 16 | 0 | A | REL | -200 | 0 | A | 0 | 0 | A | ABS |
| | C | On | | 0 | 50e-6 | 0 | 0 | A | 16 | 0 | A | REL | -200 | 0 | A | 0 | 0 | A | ABS |
| | D | On | | 50e-6 | 50e-6 | 0 | 0 | A | 16 | 0 | A | REL | -200 | 0 | A | 0 | 0 | A | ABS |
| | E | On | | 500e-6 | 2.5e-3 | 0 | 0 | A | 7 | 0 | A | REL | -200 | 0 | A | 0 | 0 | A | ABS |
| | F | Off | | 2.5e-3 | 4.8e-3 | 0 | 0 | A | -25 | 0 | A | REL | -200 | 0 | A | 0 | 0 | A | ABS |
| | G | On | | 4.8e-3 | 1.0 | 200 | 0 | A | 200 | 0 | A | ABS | -200 | 0 | A | 0 | 0 | A | ABS |
| | H to L | Off | | 0 | 0 | 0 | 0 | A | 0 | 0 | A | REL | 0 | 0 | A | 0 | 0 | A | REL |

Figure 6-44 Power vs. Time Standard Preset Values Table

Power vs Time - 2

| Standard | Region | On/Off | Info BW | Start Time | Stop Time | Upper | | | | | | | Lower | | | | | | |
|-------------------|--------|--------|---------|------------|-----------|-------|------|------------|-------|------|------------|-----------|-------|------|------------|-------|------|------------|-----------|
| | | | | | | Abs | | | Rel | | | Fail Mask | Abs | | | Rel | | | Fail Mask |
| | | | | | | Start | Stop | Aut o/M an | Start | Stop | Aut o/M an | | Start | Stop | Aut o/M an | Start | Stop | Aut o/M an | |
| | | | | | | dB m | dB m | | dB | dB | | dB m | dB m | | dB | dB | | | |
| 802.16 OFDMA 5MHz | A | On | 6M Hz | -1.0 | -50e-6 | 0 | 0 | A | -25 | 0 | A | REL | -200 | 0 | A | 0 | 0 | A | ABS |
| | B | On | | -50e-6 | 0 | 0 | 0 | A | 16 | 0 | A | REL | -200 | 0 | A | 0 | 0 | A | ABS |
| | C | On | | 0 | 50e-6 | 0 | 0 | A | 16 | 0 | A | REL | -200 | 0 | A | 0 | 0 | A | ABS |
| | D | On | | 50e-6 | 500e-6 | 0 | 0 | A | 16 | 0 | A | REL | -200 | 0 | A | 0 | 0 | A | ABS |
| | E | On | | 500e-6 | 2.5e-3 | 0 | 0 | A | 7 | 0 | A | REL | -200 | 0 | A | 0 | 0 | A | ABS |
| | F | Off | | 2.5e-3 | 4.8e-3 | 0 | 0 | A | -25 | 0 | A | REL | -200 | 0 | A | 0 | 0 | A | ABS |
| | G | On | | 4.8e-3 | 1.0 | 200 | 0 | A | 200 | 0 | A | ABS | -200 | 0 | A | 0 | 0 | A | ABS |
| | H to L | Off | | 0 | 0 | 0 | 0 | A | 0 | 0 | A | REL | 0 | 0 | A | 0 | 0 | A | REL |
| 802.16 OFDMA 7MHz | A | On | 10M Hz | -1.0 | -50e-6 | 0 | 0 | A | -25 | 0 | A | REL | -200 | 0 | A | 0 | 0 | A | ABS |
| | B | On | | -50e-6 | 0 | 0 | 0 | A | 16 | 0 | A | REL | -200 | 0 | A | 0 | 0 | A | ABS |
| | C | On | | 0 | 50e-6 | 0 | 0 | A | 16 | 0 | A | REL | -200 | 0 | A | 0 | 0 | A | ABS |
| | D | On | | 50e-6 | 500e-6 | 0 | 0 | A | 16 | 0 | A | REL | -200 | 0 | A | 0 | 0 | A | ABS |
| | E | On | | 500e-6 | 2.5e-3 | 0 | 0 | A | 7 | 0 | A | REL | -200 | 0 | A | 0 | 0 | A | ABS |
| | F | Off | | 2.5e-3 | 4.8e-3 | 0 | 0 | A | -25 | 0 | A | REL | -200 | 0 | A | 0 | 0 | A | ABS |
| | G | On | | 4.8e-3 | 1.0 | 200 | 0 | A | 200 | 0 | A | ABS | -200 | 0 | A | 0 | 0 | A | ABS |
| | H to L | Off | | 0 | 0 | 0 | 0 | A | 0 | 0 | A | REL | 0 | 0 | A | 0 | 0 | A | REL |

Figure 6-45 Power vs. Time Standard Preset Values Table

Power vs Time - 3

| Region | On/Off | Info BW | Start Time | Stop Time | Upper | | | | | | Lower | | | | | | | | |
|-----------------------|--------|---------|------------|-----------|--------|------|------------|-------|------|------------|-----------|-------|------|------------|-------|------|------------|-----------|-----|
| | | | | | Abs | | | Rel | | | Fail Mask | Abs | | | Rel | | | Fail Mask | |
| | | | | | Start | Stop | Aut o/M an | Start | Stop | Aut o/M an | | Start | Stop | Aut o/M an | Start | Stop | Aut o/M an | | |
| | | | | | dB m | dB m | | dB | dB | | | dB m | dB m | | dB | dB | | | |
| 6 A - 1 z | A | On | 10M Hz | -1.0 | -50e-6 | 0 | 0 | A | -25 | 0 | A | REL | -200 | 0 | A | 0 | 0 | A | ABS |
| | B | On | | -50e-6 | 0 | 0 | 0 | A | 16 | 0 | A | REL | -200 | 0 | A | 0 | 0 | A | ABS |
| | C | On | | 0 | 50e-6 | 0 | 0 | A | 16 | 0 | A | REL | -200 | 0 | A | 0 | 0 | A | ABS |
| | D | On | | 50e-6 | 500e-6 | 0 | 0 | A | 16 | 0 | A | REL | -200 | 0 | A | 0 | 0 | A | ABS |
| | E | On | | 500e-6 | 2.5e-3 | 0 | 0 | A | 7 | 0 | A | REL | -200 | 0 | A | 0 | 0 | A | ABS |
| | F | Off | | 2.5e-3 | 4.8e-3 | 0 | 0 | A | -25 | 0 | A | REL | -200 | 0 | A | 0 | 0 | A | ABS |
| | G | On | | 4.8e-3 | 1.0 | 200 | 0 | A | 200 | 0 | A | ABS | -200 | 0 | A | 0 | 0 | A | ABS |
| | H to L | Off | | 0 | 0 | 0 | 0 | A | 0 | 0 | A | REL | 0 | 0 | A | 0 | 0 | A | REL |
| 6 A z | A | On | 10M Hz | -1.0 | -50e-6 | 0 | 0 | A | -25 | 0 | A | REL | -200 | 0 | A | 0 | 0 | A | ABS |
| | B | On | | -50e-6 | 0 | 0 | 0 | A | 16 | 0 | A | REL | -200 | 0 | A | 0 | 0 | A | ABS |
| | C | On | | 0 | 50e-6 | 0 | 0 | A | 16 | 0 | A | REL | -200 | 0 | A | 0 | 0 | A | ABS |
| | D | On | | 50e-6 | 500e-6 | 0 | 0 | A | 16 | 0 | A | REL | -200 | 0 | A | 0 | 0 | A | ABS |
| | E | On | | 500e-6 | 2.5e-3 | 0 | 0 | A | 7 | 0 | A | REL | -200 | 0 | A | 0 | 0 | A | ABS |
| | F | Off | | 2.5e-3 | 4.8e-3 | 0 | 0 | A | -25 | 0 | A | REL | -200 | 0 | A | 0 | 0 | A | ABS |
| | G | On | | 4.8e-3 | 1.0 | 200 | 0 | A | 200 | 0 | A | ABS | -200 | 0 | A | 0 | 0 | A | ABS |
| | H to L | Off | | 0 | 0 | 0 | 0 | A | 0 | 0 | A | REL | 0 | 0 | A | 0 | 0 | A | REL |

Figure 6-46 Power vs. Time Standard Preset Values Table

Power vs Time - 4

| Standard | Region | On/Off | Info BW | Start Time | Stop Time | Upper | | | | | | Lower | | | | | | | |
|--------------------|--------|--------|---------|------------|-----------|-------|------|------------|-------|------|------------|-----------|-------|------|------------|-------|------|------------|-----------|
| | | | | | | Abs | | | Rel | | | Fail Mask | Abs | | | Rel | | | Fail Mask |
| | | | | | | Start | Stop | Aut o/M an | Start | Stop | Aut o/M an | | Start | Stop | Aut o/M an | Start | Stop | Aut o/M an | |
| | | | | | | dB m | dB m | | dB | dB | | | dB m | dB m | | dB | dB | | |
| 802.16 OFDMA 14MHz | A | On | 25M Hz | -1.0 | -50e-6 | 0 | 0 | A | -25 | 0 | A | REL | -200 | 0 | A | 0 | 0 | A | ABS |
| | B | On | | -50e-6 | 0 | 0 | 0 | A | 16 | 0 | A | REL | -200 | 0 | A | 0 | 0 | A | ABS |
| | C | On | | 0 | 50e-6 | 0 | 0 | A | 16 | 0 | A | REL | -200 | 0 | A | 0 | 0 | A | ABS |
| | D | On | | 50e-6 | 500e-6 | 0 | 0 | A | 16 | 0 | A | REL | -200 | 0 | A | 0 | 0 | A | ABS |
| | E | On | | 500e-6 | 2.5e-3 | 0 | 0 | A | 7 | 0 | A | REL | -200 | 0 | A | 0 | 0 | A | ABS |
| | F | Off | | 2.5e-3 | 4.8e-3 | 0 | 0 | A | -25 | 0 | A | REL | -200 | 0 | A | 0 | 0 | A | ABS |
| | G | On | | 4.8e-3 | 1.0 | 200 | 0 | A | 200 | 0 | A | ABS | -200 | 0 | A | 0 | 0 | A | ABS |
| | H to L | Off | | 0 | 0 | 0 | 0 | A | 0 | 0 | A | REL | 0 | 0 | A | 0 | 0 | A | REL |
| 802.16 OFDMA 15MHz | A | On | 252 MHz | -1.0 | -50e-6 | 0 | 0 | A | -25 | 0 | A | REL | -200 | 0 | A | 0 | 0 | A | ABS |
| | B | On | | -50e-6 | 0 | 0 | 0 | A | 16 | 0 | A | REL | -200 | 0 | A | 0 | 0 | A | ABS |
| | C | On | | 0 | 50e-6 | 0 | 0 | A | 16 | 0 | A | REL | -200 | 0 | A | 0 | 0 | A | ABS |
| | D | On | | 50e-6 | 500e-6 | 0 | 0 | A | 16 | 0 | A | REL | -200 | 0 | A | 0 | 0 | A | ABS |
| | E | On | | 500e-6 | 2.5e-3 | 0 | 0 | A | 7 | 0 | A | REL | -200 | 0 | A | 0 | 0 | A | ABS |
| | F | Off | | 2.5e-3 | 4.8e-3 | 0 | 0 | A | -25 | 0 | A | REL | -200 | 0 | A | 0 | 0 | A | ABS |
| | G | On | | 4.8e-3 | 1.0 | 200 | 0 | A | 200 | 0 | A | ABS | -200 | 0 | A | 0 | 0 | A | ABS |
| | H to L | Off | | 0 | 0 | 0 | 0 | A | 0 | 0 | A | REL | 0 | 0 | A | 0 | 0 | A | REL |

Figure 6-47 Power vs. Time Standard Preset Values Table

Power vs Time - 5

| Standard | Region | On/Off | Info BW | Start Time | Stop Time | Upper | | | | | | Lower | | | | | | | |
|----------------------|--------|--------|---------|------------|-----------|-------|------|------------|-------|------|------------|-----------|-------|------|------------|-------|------|------------|-----------|
| | | | | | | Abs | | | Rel | | | Fail Mask | Abs | | | Rel | | | Fail Mask |
| | | | | | | Start | Stop | Aut o/M an | Start | Stop | Aut o/M an | | Start | Stop | Aut o/M an | Start | Stop | Aut o/M an | |
| | | | | | | dB m | dB m | | dB | dB | | dB m | dB m | | dB | dB | | | |
| 802.16 OFDMA 17.5MHz | A | On | 25M Hz | -1.0 | -50e-6 | 0 | 0 | A | -25 | 0 | A | REL | -200 | 0 | A | 0 | 0 | A | ABS |
| | B | On | | -50e-6 | 0 | 0 | 0 | A | 16 | 0 | A | REL | -200 | 0 | A | 0 | 0 | A | ABS |
| | C | On | | 0 | 50e-6 | 0 | 0 | A | 16 | 0 | A | REL | -200 | 0 | A | 0 | 0 | A | ABS |
| | D | On | | 50e-6 | 500e-6 | 0 | 0 | A | 16 | 0 | A | REL | -200 | 0 | A | 0 | 0 | A | ABS |
| | E | On | | 500e-6 | 2.5e-3 | 0 | 0 | A | 7 | 0 | A | REL | -200 | 0 | A | 0 | 0 | A | ABS |
| | F | Off | | 2.5e-3 | 4.8e-3 | 0 | 0 | A | -25 | 0 | A | REL | -200 | 0 | A | 0 | 0 | A | ABS |
| | G | On | | 4.8e-3 | 1.0 | 200 | 0 | A | 200 | 0 | A | ABS | -200 | 0 | A | 0 | 0 | A | ABS |
| | H to L | Off | | 0 | 0 | 0 | 0 | A | 0 | 0 | A | REL | 0 | 0 | A | 0 | 0 | A | REL |
| 802.16 OFDMA 20MHz | A | On | 25M Hz | -1.0 | -50e-6 | 0 | 0 | A | -25 | 0 | A | REL | -200 | 0 | A | 0 | 0 | A | ABS |
| | B | On | | -50e-6 | 0 | 0 | 0 | A | 16 | 0 | A | REL | -200 | 0 | A | 0 | 0 | A | ABS |
| | C | On | | 0 | 50e-6 | 0 | 0 | A | 16 | 0 | A | REL | -200 | 0 | A | 0 | 0 | A | ABS |
| | D | On | | 50e-6 | 500e-6 | 0 | 0 | A | 16 | 0 | A | REL | -200 | 0 | A | 0 | 0 | A | ABS |
| | E | On | | 500e-6 | 2.5e-3 | 0 | 0 | A | 7 | 0 | A | REL | -200 | 0 | A | 0 | 0 | A | ABS |
| | F | Off | | 2.5e-3 | 4.8e-3 | 0 | 0 | A | -25 | 0 | A | REL | -200 | 0 | A | 0 | 0 | A | ABS |
| | G | On | | 4.8e-3 | 1.0 | 200 | 0 | A | 200 | 0 | A | ABS | -200 | 0 | A | 0 | 0 | A | ABS |
| | H to L | Off | | 0 | 0 | 0 | 0 | A | 0 | 0 | A | REL | 0 | 0 | A | 0 | 0 | A | REL |

Figure 6-48 Power vs. Time Standard Preset Values Table
Power vs Time – 6

| Standard | Region | On/Off | Info BW | Start Time | Stop Time | Upper | | | | | | Lower | | | | | | | |
|-----------------------|--------|--------|-----------|------------|-----------|-------|------|----------|-------|------|----------|-----------|-------|------|----------|-------|------|----------|-----------|
| | | | | | | Abs | | | Rel | | | Fail Mask | Abs | | | Rel | | | Fail Mask |
| | | | | | | Start | Stop | Auto/Man | Start | Stop | Auto/Man | | Start | Stop | Auto/Man | Start | Stop | Auto/Man | |
| | | | | | | dBm | dBm | | dB | dB | | dBm | dBm | | dB | dB | | | |
| WiBro 4.375M Hz | A | On | 6M Hz | -1.0 | -50e-6 | 0 | 0 | A | -25 | 0 | A | REL | -200 | 0 | A | 0 | 0 | A | ABS |
| | B | On | | -50e-6 | 0 | 0 | 0 | A | 16 | 0 | A | REL | -200 | 0 | A | 0 | 0 | A | ABS |
| | C | On | | 0 | 50e-6 | 0 | 0 | A | 16 | 0 | A | REL | -200 | 0 | A | 0 | 0 | A | ABS |
| | D | On | | 50e-6 | 500e-6 | 0 | 0 | A | 16 | 0 | A | REL | -200 | 0 | A | 0 | 0 | A | ABS |
| | E | On | | 500e-6 | 2.5e-3 | 0 | 0 | A | 7 | 0 | A | REL | -200 | 0 | A | 0 | 0 | A | ABS |
| | F | Off | | 2.5e-3 | 4.8e-3 | 0 | 0 | A | -25 | 0 | A | REL | -200 | 0 | A | 0 | 0 | A | ABS |
| | G | On | | 4.8e-3 | 1.0 | 200 | 0 | A | 200 | 0 | A | ABS | -200 | 0 | A | 0 | 0 | A | ABS |
| | H to L | Off | | 0 | 0 | 0 | 0 | A | 0 | 0 | A | REL | 0 | 0 | A | 0 | 0 | A | REL |
| WiBro 8.75MHz | A | On | 25M Hz | -1.0 | -50e-6 | 0 | 0 | A | -25 | 0 | A | REL | -200 | 0 | A | 0 | 0 | A | ABS |
| | B | On | | -50e-6 | 0 | 0 | 0 | A | 16 | 0 | A | REL | -200 | 0 | A | 0 | 0 | A | ABS |
| | C | On | | 0 | 50e-6 | 0 | 0 | A | 16 | 0 | A | REL | -200 | 0 | A | 0 | 0 | A | ABS |
| | D | On | | 50e-6 | 500e-6 | 0 | 0 | A | 16 | 0 | A | REL | -200 | 0 | A | 0 | 0 | A | ABS |
| | E | On | | 500e-6 | 2.5e-3 | 0 | 0 | A | 7 | 0 | A | REL | -200 | 0 | A | 0 | 0 | A | ABS |
| | F | Off | | 2.5e-3 | 4.8e-3 | 0 | 0 | A | -25 | 0 | A | REL | -200 | 0 | A | 0 | 0 | A | ABS |
| | G | On | | 4.8e-3 | 1.0 | 200 | 0 | A | 200 | 0 | A | ABS | -200 | 0 | A | 0 | 0 | A | ABS |
| | H to L | Off | | 0 | 0 | 0 | 0 | A | 0 | 0 | A | REL | 0 | 0 | A | 0 | 0 | A | REL |
| | E | On | | 500e-6 | 2.5e-3 | 0 | 0 | A | 7 | 0 | A | REL | -200 | 0 | A | 0 | 0 | A | ABS |
| | F | Off | | 2.5e-3 | 4.8e-3 | 0 | 0 | A | -25 | 0 | A | REL | -200 | 0 | A | 0 | 0 | A | ABS |
| | G | On | | 4.8e-3 | 1.0 | 200 | 0 | A | 200 | 0 | A | ABS | -200 | 0 | A | 0 | 0 | A | ABS |
| | H to L | Off | | 0 | 0 | 0 | 0 | A | 0 | 0 | A | REL | 0 | 0 | A | 0 | 0 | A | REL |

Figure 6-49 Power vs. Time Standard Preset Values Table

Power vs Time – 7

| Standard | Region | On/Off | Info BW | Start Time | Stop Time | Upper | | | | | | Lower | | | | | | | |
|------------------|--------|--------|---------|------------|-----------|-------|------|------------|-------|------|------------|-----------|-------|------|------------|-------|------|------------|-----------|
| | | | | | | Abs | | | Rel | | | Fail Mask | Abs | | | Rel | | | Fail Mask |
| | | | | | | Start | Stop | Aut o/M an | Start | Stop | Aut o/M an | | Start | Stop | Aut o/M an | Start | Stop | Aut o/M an | |
| | | | | | | dB m | dB m | | dB | dB | | | dB m | dB m | | dB | dB | | |
| WiBro 17.5MHz | A | On | 25M Hz | -1.0 | -50e-6 | 0 | 0 | A | -25 | 0 | A | REL | -200 | 0 | A | 0 | 0 | A | ABS |
| | B | On | | -50e-6 | 0 | 0 | 0 | A | 16 | 0 | A | REL | -200 | 0 | A | 0 | 0 | A | ABS |
| | C | On | | 0 | 50e-6 | 0 | 0 | A | 16 | 0 | A | REL | -200 | 0 | A | 0 | 0 | A | ABS |
| | D | On | | 50e-6 | 500e-6 | 0 | 0 | A | 16 | 0 | A | REL | -200 | 0 | A | 0 | 0 | A | ABS |
| | E | On | | 500e-6 | 2.5e-3 | 0 | 0 | A | 7 | 0 | A | REL | -200 | 0 | A | 0 | 0 | A | ABS |
| | F | Off | | 2.5e-3 | 4.8e-3 | 0 | 0 | A | -25 | 0 | A | REL | -200 | 0 | A | 0 | 0 | A | ABS |
| | G | On | | 4.8e-3 | 1.0 | 200 | 0 | A | 200 | 0 | A | ABS | -200 | 0 | A | 0 | 0 | A | ABS |
| | H to L | Off | | 0 | 0 | 0 | 0 | A | 0 | 0 | A | REL | 0 | 0 | A | 0 | 0 | A | REL |

Figure 6-50 Power vs. Time Standard Preset Values Table

Power vs Time - 8

| Standard | Info BW MHz | Info BW Filter | Power Reference | Time Reference | Burst Search Threshold Level | | Burst Slope Threshold dB/ms | Burst Slope Detect Intvl us | Time Reference Offset sec | IF Gain | Note |
|----------------------------|----------------|-------------------|--------------------|-------------------|------------------------------------|-----------|-----------------------------------|-----------------------------------|------------------------------------|---------|-----------------|
| | | | | | ABS or REL | Level | | | | | |
| 802.16 OFDMA 1.25MHz | 3.1 | Flattop | D | RISE | REL | - 20dB | 2.0 | 10 | 0 | Auto | |
| 802.16 OFDMA 3.5MHz | 6.7 | Flattop | D | RISE | REL | - 20dB | 2.0 | 10 | 0 | Auto | |
| 802.16 OFDMA 5MHz | 8.0 | Flattop | D | RISE | REL | - 20dB | 2.0 | 10 | 0 | Auto | |
| 802.16 OFDMA 7MHz | 10.0 | Flattop | D | RISE | REL | - 20dB | 2.0 | 10 | 0 | Auto | |
| 802.16 OFDMA 8.75MHz | 10.0 | Flattop | D | RISE | REL | - 20dB | 2.0 | 10 | 0 | Auto | |
| 802.16 OFDMA 10MHz | 10.0 | Flattop | D | RISE | REL | - 20dB | 2.0 | 10 | 0 | Auto | |
| 802.16 OFDMA 14MHz | 25.0 | Flattop | D | RISE | REL | - 20dB | 2.0 | 10 | 0 | Auto | Need B25 opt |
| 802.16 OFDMA 15MHz | 25.0 | Flattop | D | RISE | REL | - 20dB | 2.0 | 10 | 0 | Auto | Need B25 opt |
| 802.16 OFDMA 17.5MHz | 25.0 | Flattop | D | RISE | REL | - 20dB | 2.0 | 10 | 0 | Auto | Need B25 opt |
| 802.16 OFDMA 20MHz | 25.0 | Flattop | D | RISE | REL | - 20dB | 2.0 | 10 | 0 | Auto | Need B25 opt |
| 802.16 OFDMA 28MHz | | | | | | | | | | | Not available |
| WiBro 4.375MHz | 10.0 | Flattop | D | RISE | REL | - 20dB | 2.0 | 10 | 0 | Auto | |
| WiBro 8.75MHz | 10.0 | Flattop | D | RISE | REL | - 20dB | 2.0 | 10 | 0 | Auto | |
| WiBro 17.5MHz | 25.0 | Flattop | D | RISE | REL | - 20dB | 2.0 | 10 | 0 | Auto | Need B25 opt |

7

References

1. IEEE 802.16-2004 IEEE Standard for Local and metropolitan area networks Part 16: Air Interface for Fixed Broadband Wireless Access Systems
2. IEEE P802.16-2004/Cor1/D5 (“Draft Corrigendum to IEEE Standard for Local and Metropolitan Area Networks - Part 16: Air Interface for Fixed Broadband Wireless Access Systems”).
3. IEEE 802.16f-2005 IEEE Standard for Local and Metropolitan Area Networks - Part 16: Air Interface for Fixed Broadband Wireless Access Systems--Amendment 1--Management Information Base
4. 3rd Generation Partnership Project. Technical Specification Group Radio Access Network; Multiplexing and Channel Coding (FDD). Release 99. 3G TS 25.212 (V3.11.0).
5. 3rd Generation Partnership Project. Technical Specification Group Radio Access Network. Medium Access Control Protocol Specification. Release 99. 3G TS 25.321.
6. 3rd Generation Partnership Project. Technical Specification Group Radio Access Network. Radio Link Control Protocol Specification. Release 99. 3G TS 25.322.
7. 3rd Generation Partnership Project. Technical Specification Group Radio Access Network. Radio Resource Control Protocol Specification. Release 99. 3G TS 25.331.
8. 3rd Generation Partnership Project. Technical Specification Group Radio Access Network. Radio Interface Protocol Architecture. Release 99. 3G TS 25.301.
9. 3rd Generation Partnership Project. Technical Specification Group Radio Access Network; Physical Layer: Physical Channels and Mapping of Transport Channels onto Physical Channels (FDD). Release 99. 3G TS 25.211 (V3.12.0).
10. HPSK Spreading for 3G, Application Note 1335, literature number 5968-8438E.
11. 3rd Generation Partnership Project. Technical Specification Group Radio Access Network; Physical Layer: Spreading and Modulation (FDD). Release 99. 3G TS 25.213 (V3.8.0).
12. 3rd Generation Partnership Project. Technical Specification Group Radio Access Network. Physical Layer: Channel Coding and Multiplexing Examples. Release 99. 3G TS 25.944. (V3.5.0).
13. 3rd Generation Partnership Project. Technical Specification Group Terminal; Terminal Conformance Specification. Radio Transmission and Reception (FDD). Release 99. 3G TS 34.121 (V3.8.0).
14. Fundamentals of RF and Microwave Power Measurements, Application Note 64-1B, literature number 5965-6630E.
15. Wide-Range Sensor Gauges Power of Complex Signals (written by Ron Hogan and originally printed in *Microwaves & RF*, September 1999), literature number 5968-8750E.
16. Characterizing Digitally Modulated Signals with CCDF Curves, Application Note, literature number 5968-6875E.
17. Testing and Troubleshooting Digital RF Communications Transmitter Designs, Application Note 1313, literature number 5968-3578E.

References

18. Testing and Troubleshooting Digital RF Communications Receiver Designs, Application Note 1314, literature number 5968-3579E.
19. 3rd Generation Partnership Project. Technical Specification Group Radio Access Network; UE Radio Transmission and Reception (FDD). Release 99. 3G TS 25.101 (V3.5.0).
20. Connected Simulations and Test Solutions Using the Advanced Design System, Application Note 1394, literature number 5988-6044EN.
21. 3rd Generation Partnership Project. Technical Specification Group Radio Access Network; UTRAN Overall Description. Release 99. 3G TS 25.401 (V3.10.0)
22. 3GPP TS 25.141 Base Station (BS) conformance testing (FDD) (Release 5) V5.8.0 (2003-12)
23. 3GPP TS 25.211 Physical channels and mapping of transport channels onto physical channels (FDD) (Release 5) V5.5.0 (2003-9)
24. 3GPP TS 25.213 Spreading and modulation (FDD) (Release 5) V5.5.0 (2003-12)
25. 3GPP TS 25.214 Physical layer procedure (FDD) (Release 5) V5.7.0 (2003-12)
26. 3GPP TS 34.121 Terminal conformance specification; Radio transmission and reception (FDD) (Release 5) V5.1.1 (2003-12)
27. 3GPP TS 25.141 Base Station (BS) conformance testing (FDD) (Release 5) V6.10.0 (2005-06)
28. 3GPP TS 25.211 Physical channels and mapping of transport channels onto physical channels (FDD) V6.5.0 (2005-06)
29. 3GPP TS 25.212 Multiplexing and channel coding (FDD) V6.5.0(2005-06)
30. 3GPP TS 25.213 Spreading and modulation (FDD) V6.3.0 (2005-06)
31. 3GPP TS 25.214 Physical layer procedure (FDD) V6.6.0 (2005-06)
32. 3GPP TS 34.121 Terminal conformance specification; Radio transmission and reception (FDD) V6.1.0 (2005-06)

Glossary

802.16 OFDMA (WiMAX/WiBro)

OFDM orthogonal frequency division multiplexing

OFDMA orthogonal frequency division multiple access

MAC medium access control

TDMA time division multiple access

TDM time division multiplexing

TDD time division duplex

FDD frequency division duplex

H-FDD half-duplex frequency division duplex

BPSK binary phase shift keying

QPSK quadrature phase shift keying

QAM quadrature amplitude modulation

IEEE Institute of Electrical and Electronics Engineers

BS base station

SS subscriber station

TTG transmit/receive transition gap

RTG receive/transmit transition gap

BWA broadband wireless access

MCM multi-carrier modulation

PHY physical layer

FEC forward error correction

LAN local area network

MAN metropolitan area network

NLOS non-line-of-sight

LOS line-of-sight

RS Reed-Solomon block code

CP cyclic prefix

DL downlink (base station to subscriber transmission)

UL uplink (subscriber to base station transmission)

FCH frame control header

BER bit error rate

PMP point-to-multipoint

RCE relative constellation error

EVM error vector magnitude

CPE common pilot error

DLFP downlink frame prefix

HCS header check sequence

DIUC downlink interval usage code

DCD downlink channel descriptor

STC space-time coding

AAS adaptive antenna system

ISI inter-symbol interference